

Overview Of DC Disconnecter	1
Normal Operation, Installation and Transportation Conditions	2
Selection Guide	3
Model Explanation and Encoding Rules	4
Installation of DC Disconnecter	5
Accessories Installation of DC Disconnecter	7
Size and Connection	12
Electrical Wiring Diagram	16
Installation and Maintenance	19
Ordering Notes	20

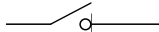

Usage and Applicability

VW3GZ-40 DC disconnector is suitable for use in DC distribution networks with rated current of 630A-4000A, rated insulation voltage of DC1600V, and rated working voltage of DC500V/DC750V/DC1000V/DC1200V/DC1500V. It is used as the main circuit for switching on and off, as an isolation device.

It has insulation function, the symbol is "  "

Criterion of DC Disconnector

- IEC 60947-1 and GB 14048.1 Low voltage switchgear and controlgear-General rules
- IEC 60947-3 and GB 14048.3 Low voltage switchgear and control equipment switches, isolators, isolating switches, and fuse combination devices
- GB2421.1 Overview and Guidelines for Environmental Testing of Electrical and Electronic Products
- GB14597 Climate and environmental conditions at different altitudes for electrical products
- GB/T2423.1 Environmental testing for electrical and electronic products - Part 2: Test methods - Test Ka: Low temperature
- GB/T2423.17 Environmental testing for electrical and electronic products - Part 2: Test methods - Test Ka: Salt spray

Our products have obtained 3C certificate.

- Recommended ambient air temperature limit is $-40^{\circ}\text{C}\sim+70^{\circ}\text{C}$, it can reach to $+70^{\circ}\text{C}$ in a short time (within 24h).
- The altitude of the installation location is less than 5000m.
- Relative humidity: not exceed 50% at the maximum ambient temperature of $+40^{\circ}\text{C}$, but higher relative humidity at the lower temperature, for example, 90% at 20°C . Special measures should be taken considering the dew on product surface due to temperature change.
- Because the environment impact the switch's lifetime, the lifetime of switch should not exceed 10% of the nominal value at the -40°C to -5°C , and the operating frequency should no more than 1 time/3 minutes ; the switch lifetime of 100% of the nominal value, and an operating frequency of no more than once per minute at $-5^{\circ}\text{C}\sim50^{\circ}\text{C}$; the switch lifetime of 10% of the nominal value, and an operating frequency of no more than once per minute at $50^{\circ}\text{C}\sim70^{\circ}\text{C}$. Test the temperature rise and dielectric properties after the operation
- Pollution grade 3.
- Usage category: DC-PV2
- Salt spray: GB2423.18, severity level 2
- IV for main circuit and under-voltage release coil and power supply transformer primary coil; III for other auxiliary and control circuits.
- The vertical gradient: no more than 5° . It should be installed in an environment of without explosive hazards, conductive dust, and sufficient corrosion of metals and insulation damage.
- Transportation and storage conditions: $-40\sim+55^{\circ}\text{C}$, it can reach to $+70^{\circ}\text{C}$ in a short time (within 24h).
- The protection level is IP40

Series

VW3GZ-40

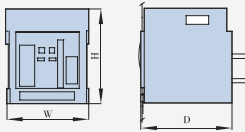

Rated current I_n (A)		630, 800, 1000, 1250, 1600, 2000, 2500, 2900, 3200, 3600, 4000
Rated working voltage U_e (V)50Hz/60Hz		DC500/750/1000/1200/1500
Rated insulation voltage U_i (V)		1600
Rated impulse withstand voltage U_{imp} (kV)		15
Number of poles		2P
Rated short circuit making capacity (peak value) I_{cm} (kA)		100
Rated short-time withstand current (effective value) I_{cw} (kA) 1s		100kA 1s 150kA 0.2
Electrical life (times)		1000
Operating performance	Mechanical life (times)	12500
	Without maintenance	30000
Operational condition	Utilization category	DC-PV2
	Pollution degree	3
	Protection grade	IP40
	Ambient temperature	$\geq -40^{\circ}\text{C}$
	Altitude	$\leq 5000\text{m}$
Outline dimension(mm)		Fixed type 2p 395 x 318.5 x 321
(H x W x D)		Fixed type 3p /
		Fixed type 4p /

Note: Derating is required when the temperature of VW3Z-40 exceeds 40°C.
Refer to the temperature derating table for specific requirements.

Model Explanation and Encoding Rules

VW3GZ - □ □ / □ □ / □ □ □ □ □ □ □ □ / □ □ / □ □ / □

1 2 3 4 5 6 7 8 9 10 11 12 13 14 15 16

SN	Name	Specification, type code	Description
1	Design code	VW3GZ: Design code	/
2	Frame rating	40: 4000A	/
3	Breaking type	Empty: Standard breaking level	/
4	Rated current	06:630A; 08:800A; 10: 1000A; 12: 1250A; 16: 1600A; 20: 2000A; 25: 2500A; 29: 2900A; 32: 3200A; 36: 3600A; 40: 4000A	/
5	Installation mode	F: Fixed type;	/
6	Number of poles	2: 2P; 3: 3P; 4: 4P	/
7	Electric energy storage mechanism	D1:AC400V; D2:AC230V/DC220V; D4: AC/DC110V; D5:DC24V	/
8	Shunt release	F1:AC400V; F2:AC230V/DC220V; F4: AC/DC110V; F5:DC24V	/
9	Closed electromagnet	B1:AC400V; B2:AC230V/DC220V; B4: AC/DC110V; B5:DC24V	/
10	Under-voltage release / Loss of voltage release /	Under-voltage release Q1: AC400V; Q2: AC230V; Q5: DC24V Loss of voltage release S1: AC400V; S2: AC230V	1. Choose one from the Under-voltage release, Loss of voltage release,
11	Under-voltage release / loss of voltage release Delay time	0: Instantaneous; 1: 1s delay; 3: 3s delay; 5: 5s delay	/
12	Auxiliary contact	A33: 3NO3NC; A44: 4NO4NC; ... ; A1414: 14NO14C A3: Three-group switching; A4: Four-group switching; ... ; A14: Fourteen-group switching	/
13	Internal Accessories	BX: Closing ready signal output unit; JS: Counter functional unit	/
14	External accessories	S: Button lock	/
15	Wiring mode	C1: Horizontal wiring; C2: Vertical wiring; C4: Mixed wiring(upper horizontal,lower vertical); C5: Mixed wiring(upper vertical,lower horizontal); 1: Standard wiring	/
16	Language type	Empty: Chinese; Y: English	/

Interlocking Piece Model Explanation and Encoding Rules

Key lock	SF11: Key lock device (one lock and one key) SF21: Key lock device(two locks and one key) SF22: Key lock device (two locks and two keys) SF31: Key lock device(three locks and one key) SF32: Key lock device (three locks and two keys) SF53: Key lock device(five locks and three keys)	Select one from six key locks;
Mechanical interlocking	SR11: Mechanical interlocking device (two sets of steel cables,one for closing and one for opening) SR12: Mechanical interlocking device (three sets of steel cables,one for closing and two for opening) SR21: Mechanical interlocking device (three sets of steel cables,two for closing and one for opening) SY11: Mechanical interlocking device (two sets of hard rods,one for closing and one for opening)	Select one from four key interlocks;

Connection of Ground Terminal

It should be cleaned before grounding of the fixed type DC disconnector. And connect the PE wire to grounding bar of the switchgear by M12.

The area of wire refers to the following table.

Cross-sectional area of phase wire (mm ²)	Corresponding protective conductor (minimum cross-sectional area of PE (mm ²))
35 < S ≤ 400	S/2
400 < S ≤ 800	200
S > 800	S/4

Derating Coefficient

If the ambient temperature is higher than +40°C, capacity can be corrected according to the following table

Type	Rated current (A)	+40°C	+45°C	+50°C	+55°C	+60°C	+65°C	+70°C
VW3GZ-40	630~2500	1	1	1	1	1	/	1
	2900	1	1	1	1	1	/	0.96
	3200	1	1	1	1	0.94	/	0.92
	3600	1	1	1	0.94	0.92	/	0.9
	4000	1	0.95	0.92	0.89	0.85	/	0.85

Note: The above data is calculated based on experiments and theories, and only for guidance and recommendations.

If the altitude exceeds or equals to 2000m, the electric property can be corrected according to the following table;

Altitude (m)	2000	3000	4000	4500	5000
Rated current(A)	1.0I _n	0.9I _n	0.88I _n	0.85I _n	0.82I _n
Breaking capacity	1.0	0.98	0.93	0.88	0.85

Installation of DC Disconnector

Copper busbar specification

Frame size rated current I_{nm} (A)	Rated current I_n (A)	Copper busbar specification		
		Number of busbar		Dimension
		Horizontal wiring	Vertical wiring	
VW3GZ-16	630	2	1	80×5
	800	2	1	80×5
	1000	2	1	80×5
	1250	2	1	100×5
	1600	2	1	100×5
	2000	3	2	100×5
	2500	4	3	100×5
	2900	3	2	100×10
	3200	4	3	100×10
	3600	5	4	100×10
4000	5	4	100×10	

Note 1: The table shows that the DC disconnector is installed in an open environment with a maximum ambient temperature of 40 °C and meets the copper bar specifications specified in GB/T 14048.3 for heating conditions. If the temperature exceeds 40 °C, the breaking capacity should be reduced or the number of copper bars should be increased.

Note 2: The maximum allowable temperature for copper bars should not exceed 110 °C.

Recommended screw used of outlet busbar diameter

Switch Disconnecter type	Outlet busbar diameter	Screws grade 8.8 (with washer)	Tightening torque
VW3GZ-40	Φ13	M12	70N.m

Wiring method for copper bars

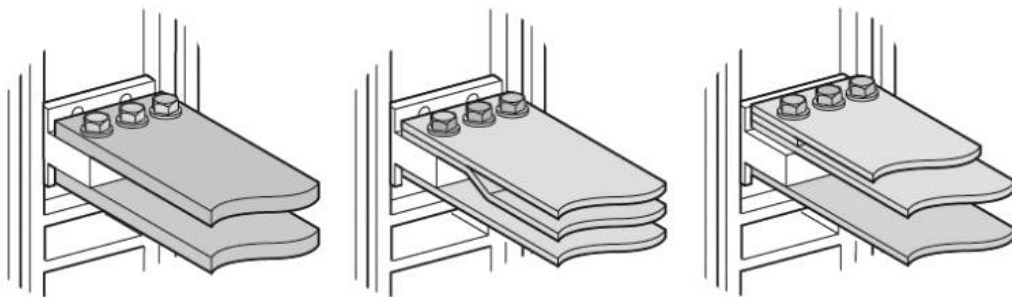

Closed Electromagnet (B)



The closing solenoid is primarily composed of a coil, iron core assembly, and electronic components. When energy storage is completed and the closing operation is ready, energizing the closing solenoid enables instantaneous release of the stored energy in the operating mechanism, causing rapid closure of the circuit breaker. The shunt trip device has no overvoltage protection function. It can withstand 1.4 times the rated control supply voltage (1.4Us) for 1 second. Prolonged energization may cause burnout. The device is capable of 100 operations at 1.4Us with a maximum operating frequency of one operation per 3 minutes.

Rated insulation voltage(Ui)	VW3GZ-40		
	(Us)	Pickup Inrush Current	Pickup Inrush Power
400V	AC230V/DC220V	2.5A	550W
	AC400V	2.1A	780W
	AC110V/DC110V	5.2A	550W
	AC48V/DC48V	7.5A	360W
	AC24V/DC24V	11A	264W
	DC24V	11A	264W
Operating voltage	(0.85-1.1)Un		
Movement time (ms)	< 50ms		

Accessories Installation of DC Disconnect

Shunt Release (F)

To break the DC disconnect by remote control



Power Consumption Table of Shunt Release

Rated insulation voltage(Ui)	VW3GZ-40		
	(Us)	Pickup Inrush Current	Pickup Inrush Power
400V	AC230V/DC220V	2.5A	550W
	AC400V	2.1A	780W
	AC110V/DC110V	5.2A	550W
	AC48V/DC48V	7.5A	360W
	AC24V/DC24V	11A	264W
	DC24V	11A	264W
Operating voltage	(0.7-1.1)Un		
Movement time (ms)	< 50ms		

Motor operating mechanism (D)



The circuit breaker's spring charging is accomplished by a motor-operated mechanism, featuring both motor-powered energy storage and automatic recharging functions (manual charging is also available). It has no overvoltage protection capability. The device can withstand 1.4Us for 1 second, but prolonged energization may cause burnout. The mechanism can operate 100 cycles at 1.4Us with a maximum frequency of once every 3 minutes.

Rated control supply voltage Us (V)	AC230/DC220	AC400	AC110/DC110	AC48/DC48	AC24/DC24
Operation voltage	(85%-110%) Us				
Operating power	150W				
Starting power	500-600W				
Energy storage time(s)	≤5				
Motor type	Brush motor				

Auxiliary contact

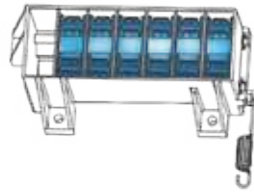

Rated insulation voltage	400V		
Conventional thermal current	16A		
Usage category	AC-12	AC-15	DC-12
Rated working voltage	AC380V	AC400V	DC250V
Rated working current	16A	3A	5A

Type	Code	Type	Code
3NO3NC	A33	4NO4NC	A44
5NO5NC	A55	6NO6NC	A66

Note:

- 1.VW3GZ-40 series only have 3NO 3NC~6NO 6NCNO,"N66"indicates contacts with no common point,while "N6"denotes contacts with a common point The same logic applies to other codes
- 2.Standard configuration includes E3/E33 contact arrangements
- 3.The auxiliary contacts support a minimum load of DC24V 10mA

Undervoltage (loss-of-voltage) release (Q)



In the electrified networks where thunder and rain often happens or whose power supply is not stable, under-voltage release with time delay is highly recommended to protect the DC disconnecter from releasing due to transient voltage-lowering. Time delay 1s,3s and 5s can be selected by the user. If there are some special requirements about time delay, please contact us.

Rated operational voltage (V)		Undervoltage release				Loss-of-voltage release			
		AC230V/ DC220V	AC400V	AC110V/ DC110V	AC48V/ DC48V	AC230V/ DC220V	AC400V	AC110V/ DC110V	AC48V/ DC48V
Action type	Type	Code							
	Instantaneous time	Q10	Q20	Q30	Q40	Q50	Q60	Q70	Q80
	Delay time 1s	Q11	Q21	Q31	Q41	Q51	Q61	Q71	Q81
	Delay time 3s	Q13	Q23	Q33	Q43	Q53	Q63	Q73	Q83
	Delay time 5s	Q15	Q25	Q35	Q45	Q55	Q65	Q75	Q85
Operation voltage (V)		(35%-70%) Ue				(10%-35%) Ue			
Guarantee the reliable closing voltage (V)		(85%-110%) Ue							
Not guarantee the reliable closing voltage		≤ 0.35%Us							
Maintain power consumption(W)		4.14W	6.54W	8.6W	6.2W	1.89W	2.5W	2.38W	/

Phase separator

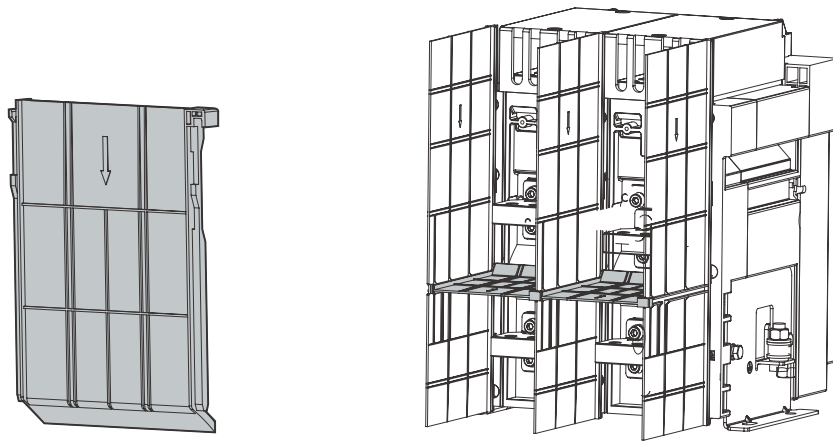

Installed vertically between the terminal blocks of the fixed part of a fixed-mounted DC disconnector, it enhances the insulation strength at the busbar connection points and prevents arc propagation into the breaker's interior.

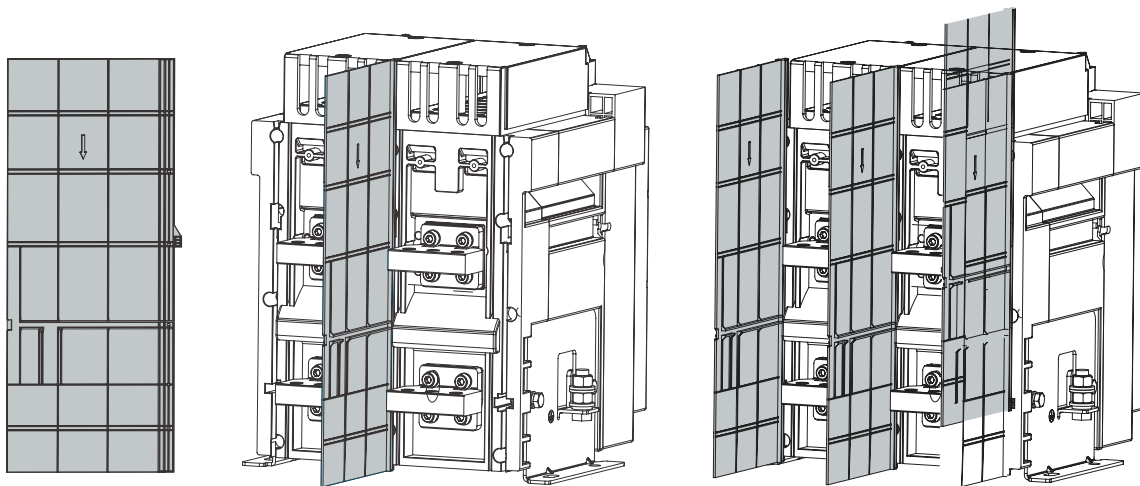

OFF-position key lock (SF11, SF21, SF31, SF32, SF53, SF22)

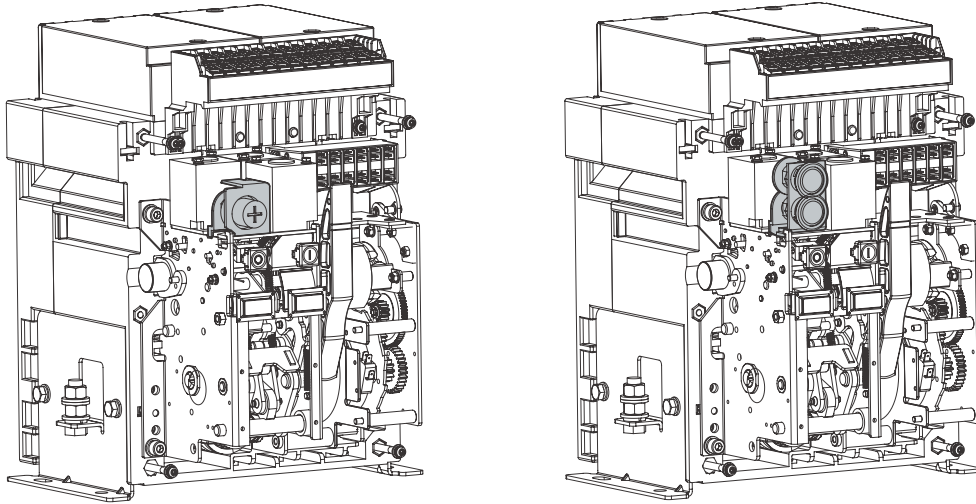

The open-position lock secures the trip button in the depressed position. When selected by the customer, we will install and configure it. Usage method:

(1) key lock:

One lock one key (SF11): One DC disconnect with one same lock and one key, and only allowed to closed when locked.

Two locks one key (SF21): Two DC disconnectors with two same locks and one key, and only allowed one DC disconnecter closed.

Three locks one key (SF31): Three DC disconnectors with three same locks and one key, and only allowed one DC disconnecter closed.

Three locks two keys (SF32): Three DC disconnectors with three same locks and two keys, and only allowed two DC disconnectors closed.

Five locks three keys (SF53): Five DC disconnectors with five same locks and three keys, and only allowed three DC disconnecter closed.

(2) Double interlock (SF22): With two different sets of keys and locks.

Size and Connection

Fixed type (VW3GZ-40, 2900-3200A)

Front view

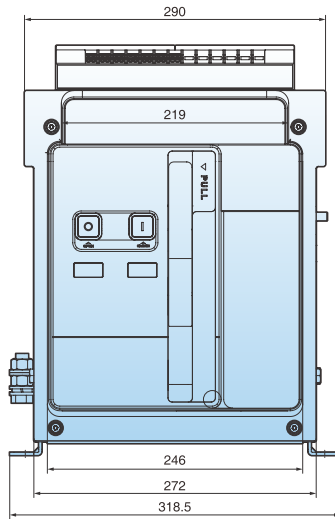

Vertical Wiring

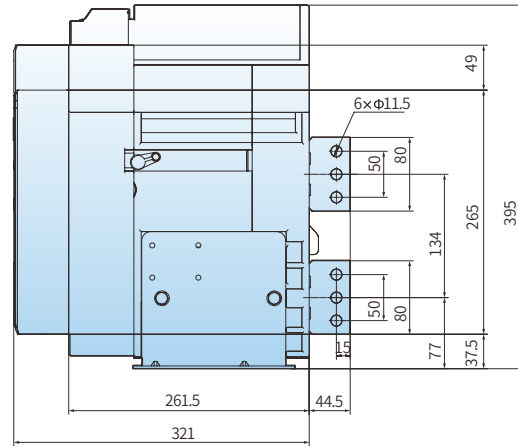
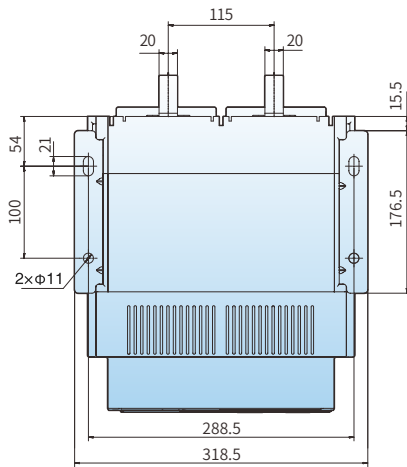

Horizontal Wiring

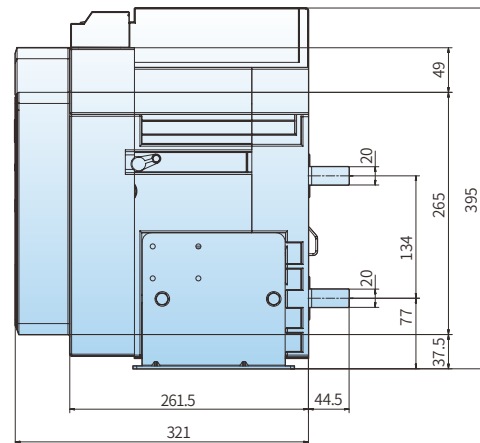
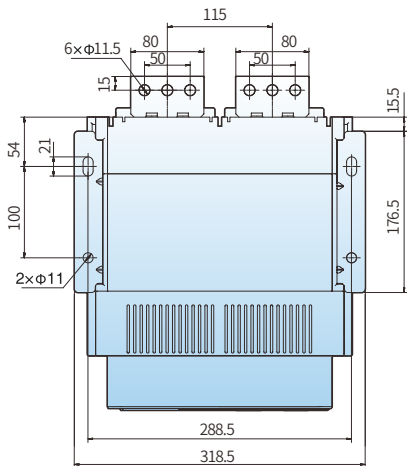

Size and Connection

Fixed type (VW3GZ-40, 3600-4000A)

Front view

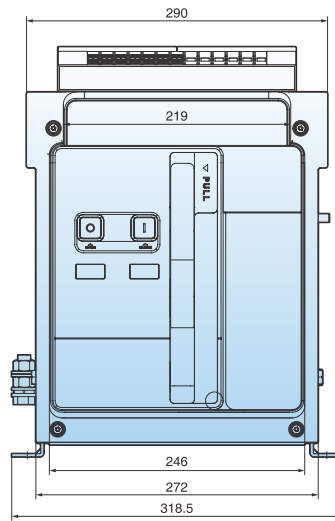

Vertical Wiring

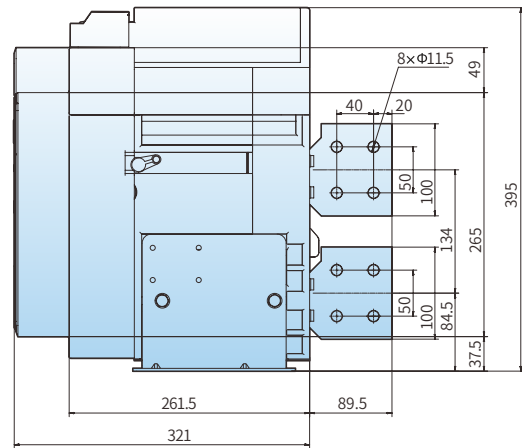
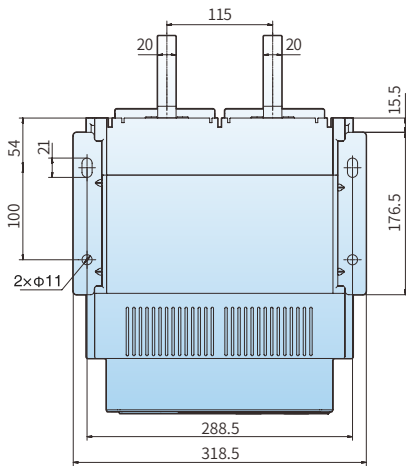

Horizontal Wiring

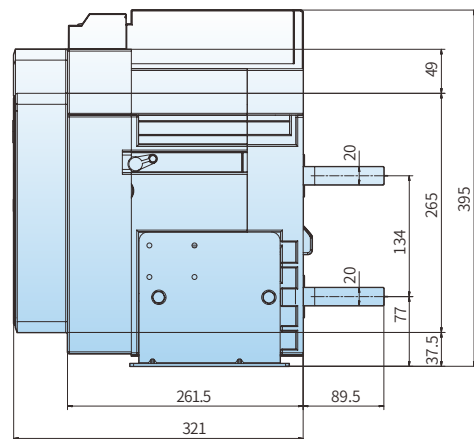
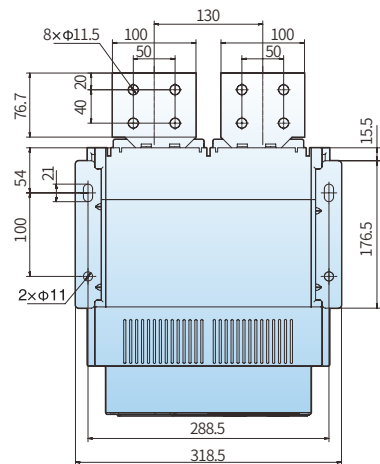

Size and Connection

When users install the DC disconnecter into the cabinet, the safe distance between the DC disconnecter and the cabinet is shown in the figure below, and the installation dimensions are shown in the table below.

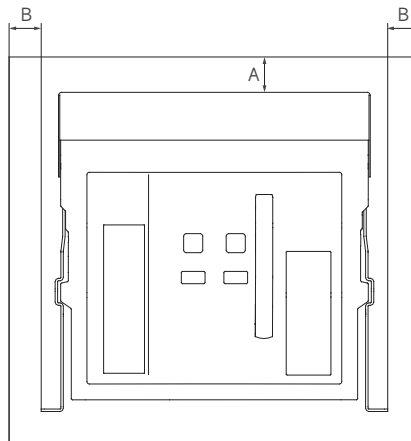

Fixed type switch disconnector

unit: mm

Installation type of	To the insulator		To the metallic body grounded safely		To the live part	
	A	B	A	B	A	B
Fixed type	0	0	0	0	80	80

Note: The safety distance for fixed switches should consider a space of 40mm required to remove the arc extinguishing chamber;

VW3GZ-40

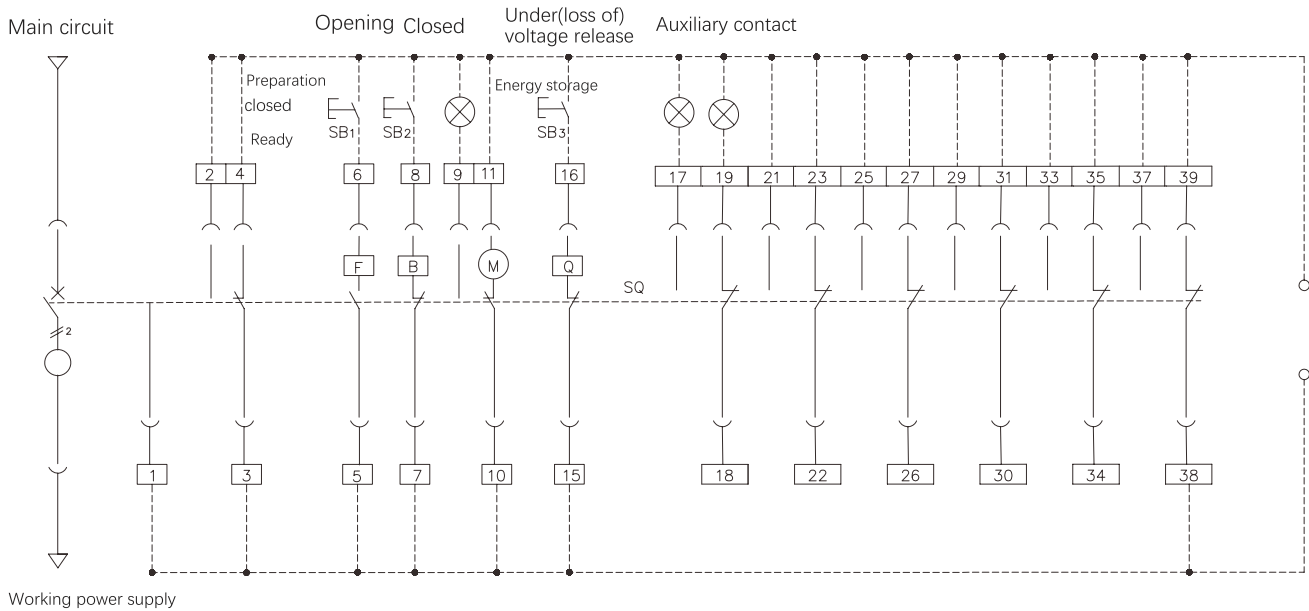

Note:

- SB1 Open button SB3 Undervoltage release button B Closed electromagnet SQ Auxiliary contact
- SB2 Close button F Shunt release M Motor operating mechanism

Terminal Number Description

Terminal Number	Description
1#	Grounding terminal
2#, 3#, 4# (Optional)	Closing ready terminal
5#, 6#	Shunt release terminal
7#, 8#	Closing release terminal
9#, 10#, 11#	Motor operator terminal
15#, 16# (Optional)	Undervoltage release terminal
17#-28#	Auxiliary contact terminal 3no3nc
29#-40# (Optional)	Auxiliary contact terminals

Note:

External wiring diagram shows buttons and indicators to be provided by the user

VW3GZ-40 (No common point)

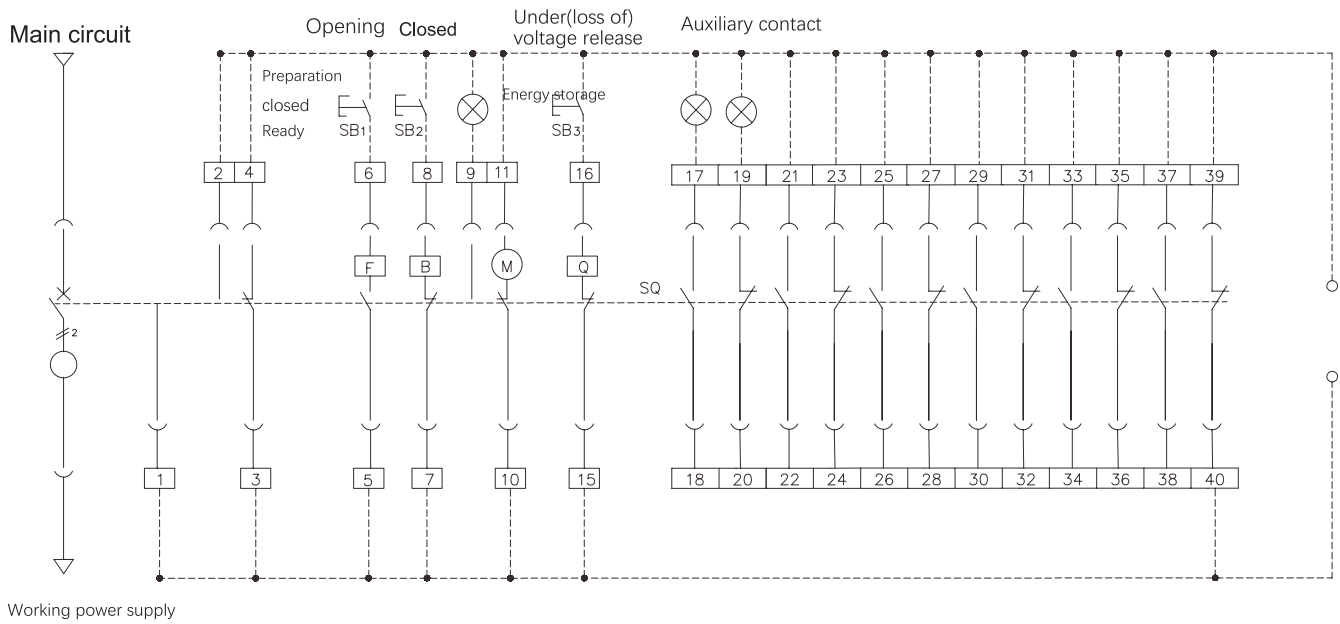

Note:

SB1 Open button SB3 Undervoltage release button B Closed electromagnet SQ Auxiliary contact
 SB2 Close button F Shunt release M Motor operating mechanism

Terminal Number	Description
1#	Grounding terminal
2#, 3#, 4# (Optional)	Closing ready terminal
5#, 6#	Shunt release terminal
7#, 8#	Closing release terminal
9#, 10#, 11#	Motor operator terminal
15#, 16# (Optional)	Undervoltage release terminal
17#-28#	Auxiliary contact terminal 3NO3NC
29#-40# (Optional)	Auxiliary contact terminals

Note:

External wiring diagram shows buttons and indicators to be provided by the user.

The selection of switchgear in DC systems mainly considers the following aspects:

- Rated working voltage, considering the number of series connected poles for disconnection
- Rated current, considering load power
- Grounding system method
 - a. Three pole series isolation switch - B-type wiring method
 - b. Four pole series isolation switch - C-type wiring method

Recommended wiring method for VW3GZ DC disconnect

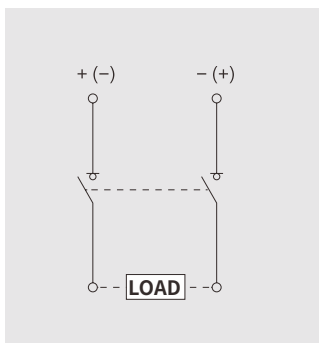

Wiring method 1

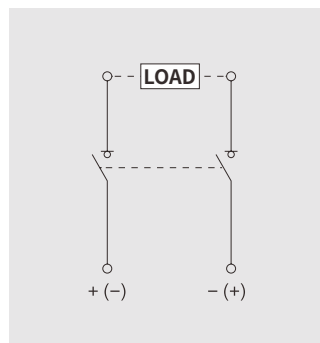

Wiring method 2

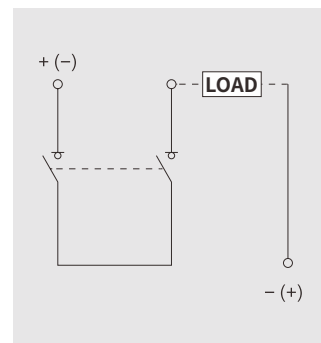

Wiring method 3

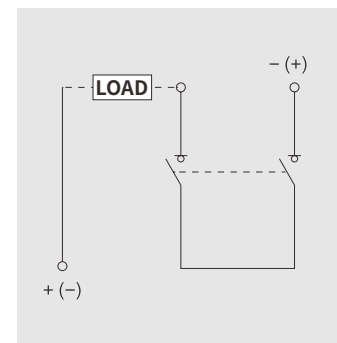

Wiring method 4

Installation employment warnings

1. Confirm that the specifications of the DC disconnecter meet the usage requirements before installation.
2. The product should be installed in a location that without of explosion hazards, conductive dust, and has no potential to damage metals or insulation.
3. During installation, forbidden other materials fall into the product.
5. Before installation, measure the insulation resistance of the isolation switch with a 500V megohmmeter. The insulation resistance should not be less than 500MΩ at an ambient air temperature of 20 °C± 5 °C and a relative temperature of 50% -70%. Otherwise, it should be dried until the insulation resistance meets the requirements before use.
6. During installation, the conductive busbar connected to the switch should be flat and free from additional mechanical stress.
7. During installation, the switch must be reliably grounded for protection, and there should be a clear grounding symbol at the grounding point.
8. After the installation, the following steps must be tested before the main circuit is powered on to ensure everything is normal before it can be officially powered on.
9. Carefully check for any other materials falling into the DC disconnecter, and if so, thoroughly remove them. The DC disconnecter must be kept clean.
10. Install the DC disconnecter according to the control circuit (secondary circuit) and connect it properly according to the wiring diagram. Check whether the working voltage of related components such as undervoltage/undervoltage, shunt release, closing electromagnet, energy storage motor, etc. matches the actual voltage, and then power on the secondary circuit. After the energy storage motor stores energy, press the closing button (electric or manual) to close the isolation switch.
11. Press the disconnect button (electric or manual) to open the DC disconnecter.
12. When manually storing energy, the handle on the front panel should be pulled up and down, and after seven times, the panel will display "Energy Storage". And hear a 'click' sound, the energy storage ends. If there is an undervoltage release at this time, power on (if not needed), and then perform the closing operation.

Maintenance

- Every rotating part should be infused with lubrication oil periodically during using.
- Dust should be cleaned periodically so as to keep good insulation level of the DC disconnecter.
- Contacts system should be checked periodically you should check it after short circuit current breaking.

Contents to be checked:

- Whether the arc chute is in good condition
- Whether the contacts have good contact
- Whether fasteners of every connection part are in good connection

Ordering Notes

Please fill in numbers in _____, and check ✓ in

User: Number of units ordered: Date of ordering:		
Basic parameters	Shell frame level	<input type="checkbox"/> VW3GZ-4000
	Installation mode	F-Fixed type
	Rated current(A)	VW3GZ-4000 <input type="checkbox"/> 630 <input type="checkbox"/> 800 <input type="checkbox"/> 1000 <input type="checkbox"/> 1250 <input type="checkbox"/> 1600 <input type="checkbox"/> 2000 <input type="checkbox"/> 2500 <input type="checkbox"/> 2900 <input type="checkbox"/> 3200 <input type="checkbox"/> 3600 <input type="checkbox"/> 4000
	Breaking type	<input type="checkbox"/> Empty: Standard breaking level
	Number of poles	<input type="checkbox"/> 2-2P <input type="checkbox"/> 3-3P <input type="checkbox"/> 4-4P
	Wiring mode	VW3GZ-4000: <input type="checkbox"/> C1-Horizontal wiring <input type="checkbox"/> C2-Vertical wiring <input type="checkbox"/> C4-Mixed wiring(upper horizontal,lower vertical) <input type="checkbox"/> C5-Mixed wiring(upper vertical,lower horizontal) <input type="checkbox"/> 1-Standard wiring
Required accessories	Electric operating mechanism	<input type="checkbox"/> D1-AC400V <input type="checkbox"/> D2-AC230V/DC220V <input type="checkbox"/> D4-AC/DC110V <input type="checkbox"/> D5-DC24V
	Shunt release	<input type="checkbox"/> F1-AC400V <input type="checkbox"/> F2-AC230V/DC220V <input type="checkbox"/> F4-AC/DC110V <input type="checkbox"/> F5-DC24V
	Closed electromagnet	<input type="checkbox"/> B1-AC400V <input type="checkbox"/> B2-AC230V/DC220V <input type="checkbox"/> B4-AC/DC110V <input type="checkbox"/> B5-DC24V
Optional accessories	Under-voltage release	Voltage specifications <input type="checkbox"/> Q1-AC400V <input type="checkbox"/> Q2-AC230V <input type="checkbox"/> Q5-DC24V
		Delay time <input type="checkbox"/> 0-Instantaneous <input type="checkbox"/> 1-1s delay <input type="checkbox"/> 3-3s delay <input type="checkbox"/> 5-5s delay
	Loss of voltage release	Voltage specifications <input type="checkbox"/> S1-AC400V <input type="checkbox"/> S2-AC230V
		Delay time <input type="checkbox"/> 0-Instantaneous <input type="checkbox"/> 1-1s delay <input type="checkbox"/> 3-3s delay <input type="checkbox"/> 5-5s delay
	Auxiliary contact	<input type="checkbox"/> A33-3NO3NC <input type="checkbox"/> A44-4NO4NC <input type="checkbox"/> A55-5NO5NC <input type="checkbox"/> A66-6NO6NC <input type="checkbox"/> ____NO____NC(Max.14)
		<input type="checkbox"/> A3-Three-group switching <input type="checkbox"/> A4-Four-group switching <input type="checkbox"/> BX-Closing ready signal output unit <input type="checkbox"/> A6-Six-group switching <input type="checkbox"/> ____-group switching(Max.14)
	Closing ready	<input type="checkbox"/> BX-Closing ready signal output unit
	Counter	<input type="checkbox"/> JS-Counter
Button lock	<input type="checkbox"/> S-Button lock	
Language type	<input type="checkbox"/> Chinese <input type="checkbox"/> Y-English	
Interlocking Off-position lock accessories	<input type="checkbox"/> SF11-Key lock device(one lock and one key) <input type="checkbox"/> SF21-Key lock device(two locks and one key) <input type="checkbox"/> SF31-Key lock device (three locks and one key) <input type="checkbox"/> SF22-Key lock device(two locks and two keys) <input type="checkbox"/> SF32: Key lock device(three locks and two keys) <input type="checkbox"/> SF53: Key lock device (five locks and three keys)	
Mechanical interlocking	<input type="checkbox"/> SR11-two sets of steel cables, one for closing and one for opening <input type="checkbox"/> SR12-three sets of steel cables, one for closing and two for opening <input type="checkbox"/> SR21-three sets of steel cables, two for closing and one for opening <input type="checkbox"/> SY11-two sets of hard rods, one for closing and one for opening	
Other requirements		