

## VM3-HU Series User Manual

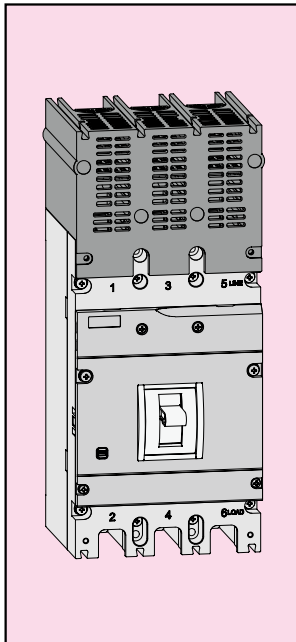

V1.4 202411



**Electric Current!**  
**Danger to life!**

Only skilled or instructed persons may carry out the following operations

Shanghai Vozwei Electric Technology Co., Ltd.

### VM3-250HUL/HUM/HUH 1

Connection	6	GB70.1 M8×25 GB93 8 GB971 8	
Installation of Circuit-breaker	4	GB9074.8 M4×100	
Installation of terminal cover	2	GB9074.8 M3×10 4 GB9074.8 M4×75	

mm

Hexagon wrench    Cross screwdriver

### Front Panel Connection VM3-250HUL/HUM/HUH 2

With terminal expander

Without terminal expander

GB70.1 M8×25  
GB93 8  
GB971 8

### Installation of Terminal cover VM3-250HUL/HUM/HUH 3

GB9074.8 M3×10  
GB9074.8 M4×75

Note: Standard

Note: Standard

Note: When users use, terminal cover should be assembled on terminals 1,3 and 5 of circuit breaker according to graphics. Insulation board is installed between circuit breaker and metal installation board.

Note

- Insulation board must be installed.
- If  $F < 8\text{mm}$  at the load, the insulation board must be enlarged.

### Installation of phase separator VM3-250HUL/HUM/HUH 4

Phase separator (short)  
Insulation board  
Terminal cover  
Phase separator (long)

Attention direction

Note1: Insulation board is standard configuration. If the beam is installed, it can be cut off by itself, but the dimension  $H \ge 40\text{mm}$  should be ensured.

Note2: The standard configuration of phase separators is 8, and 4 short and 4 long. When the number of circuit breakers installed side by side is  $\ge 2$ , please keep the installation position of the phase interphase clapboard of the side phase consistent (all installed on phase A side or phase C side), 1 long and 1 short (phase separator) should be added for the side phase of the circuit breaker close to the metal cabinet.

### Circuit breaker installation Safety distance VM3-250HUL/HUM/HUH 5

The minimum spacing between adjacent circuit breakers

The minimum spacing of the top, baseplate and side plate of the circuit breaker

The minimum insulation length of wiring bar when it is front panel connection

The minimum spacing between the circuit breaker and front panel

Model	Distance (mm)							G	
	A	B	C	D1	D2	E	F		
VM3-250HUL/HUM/HUH	120	228	30	146	30	178.9	350	0	30

Note: When users use, terminal cover and Short phase separator should be assembled on terminals 1,3 and 5 of circuit breaker according to graphics. Long phase separator should be assembled on terminals 2,4 and 6 of circuit breaker according to graphics. Insulation board is installed between circuit breaker and metal installation board.

### Electrical accessories installation VM3-250HUL/HUM/HUH 6

Note

All accessories should be installed in the tripping state of circuit breaker (the handle in the middle position which is marked as "Trip")

### Lead direction of internal accessories

Note

After the accessories are installed, the accessory lead must pass through the lead groove as shown in the figure to avoid the hidden danger of wire pressing during the installation

VM3-630HUL 1

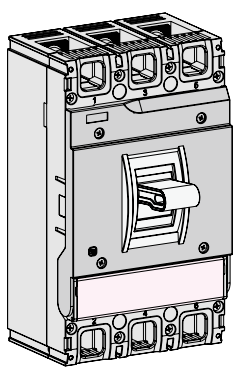

Connection	6	GB70.1 M10X25 DIN6796 Φ10	
Installation of Circuit-breaker	4	GB9074.7 M6X65 GB971 6 GB6170 M6	
Installation of terminal cover	2	GB845 ST2.9X9.5C	
	4	GB9074.8 M4X50	

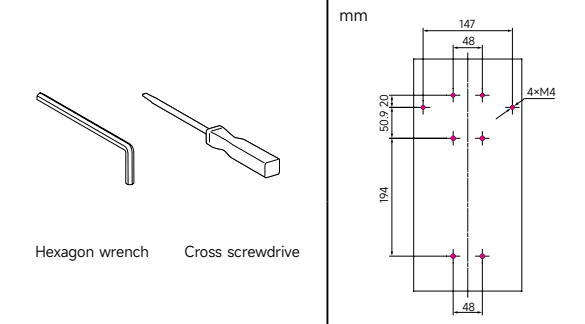

Front Panel Connection VM3-630HUL 2

With terminal expander

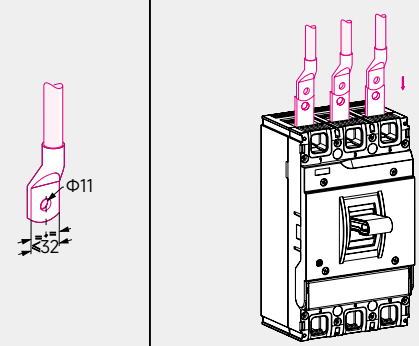

Front Panel Connection VM3-630HUL

Without terminal expander

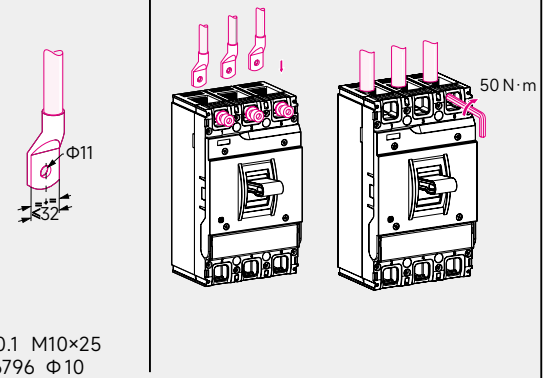

Installation of Terminal cover VM3-630HUL 3

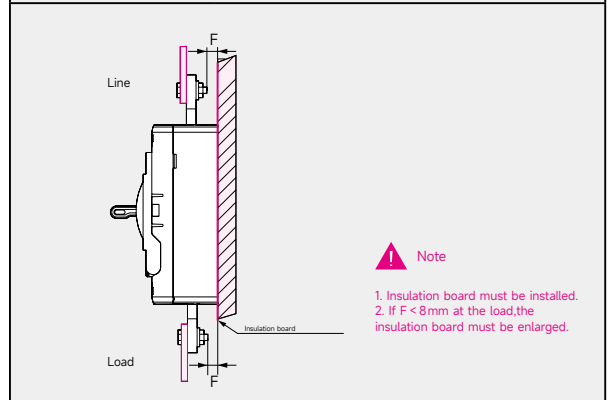
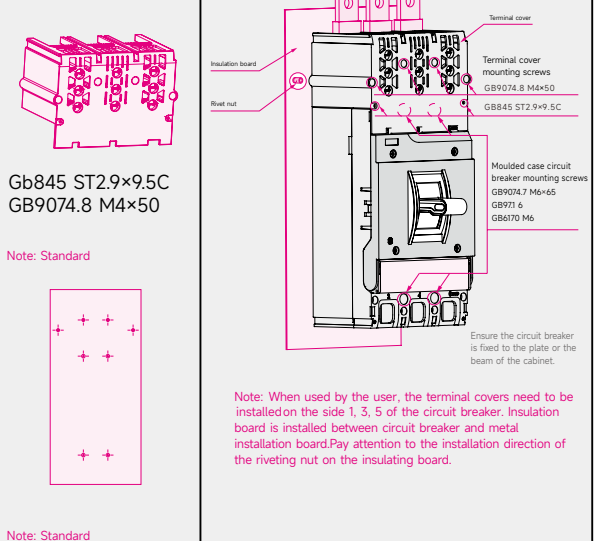

Installation of phase separator VM3-630HUL 4

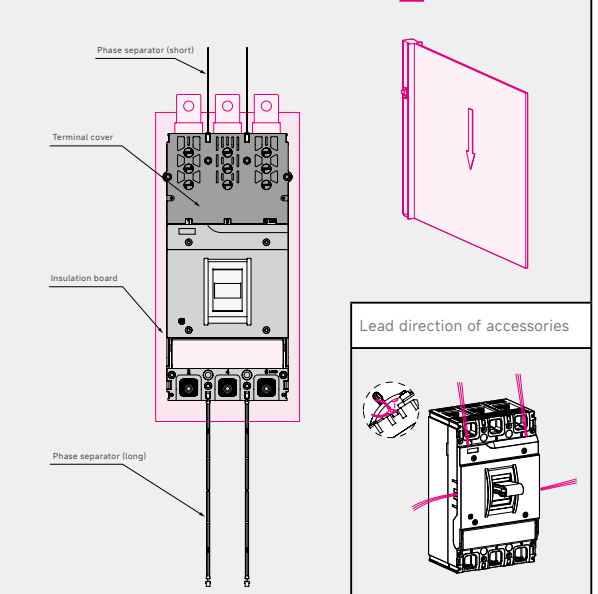

Electrical accessories installation VM3-630HUL

	Insulator	Shunt release (SHT)		
	Under-voltage release (UVT)	Auxiliary/Alarm (AX/AL)		
	Name	Position	Name	Position
	SHT	L2+L3/R2+R3	AX	L1/L2/L3/R1/R2/R3
	UVT	L2+L3/R2+R3	AL	L1/L2

Circuit breaker installation Safety distance VM3-630HUL 5

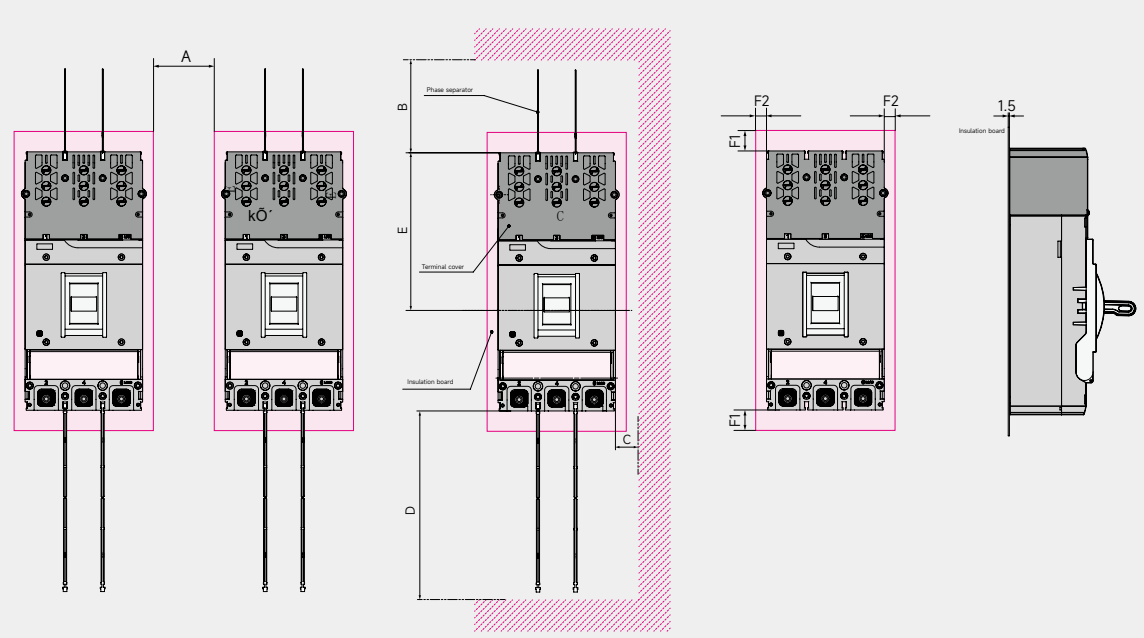

Model	A	B	C	D	E	F1	F2
VM3-630HUL	30	150	30	180	201.5	26	14

Note: When used by the user, terminals 1,3 and 5 of the circuit breaker connect to transformer side and install terminal cover and phase separator according to graphics. Terminals 2,4 and 6 connect to inverter side and install phase separator according to graphics. Insulation board is installed between circuit breaker and metal installation board.

Motor operator (CD) VM3-630HUL 6

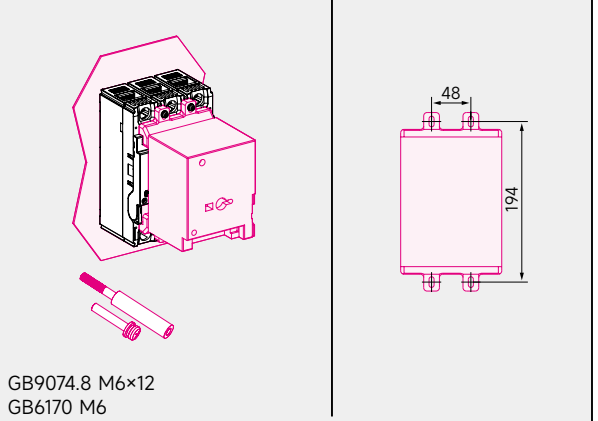

Manual operator (CS) VM3-630HUL

