



## VW3GZ-16 Series of DC Disconnector

### Product Specification

Overview Of DC Disconnecter .....	1
Normal Operation, Installation and Transportation Conditions .....	2
Selection Guide .....	3
Model Explanation and Encoding Rules .....	4
Installation of DC Disconnecter .....	6
Accessories Installation of DC Disconnecter .....	7
Size and Connection .....	11
Electrical Wiring Diagram .....	14
Installation and Maintenance .....	16
Ordering Notes .....	17



## Usage and Applicability

VW3GZ-16 DC Disconnector is suitable for use in DC distribution networks with rated current of 200A-1600A, rated insulation voltage of DC1600V, and rated working voltage of DC1000V/DC1500V. It is used as the main circuit for switching on and off, as an isolation device.

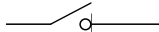
It has insulation function, the symbol is "  "

## Criterion of Switch Disconnector

- IEC 60947-1 and GB 14048.1 Low voltage switchgear and controlgear-General rules
- IEC 60947-3 and GB 14048.3 Low voltage switchgear and control equipment switches, isolators, isolating switches, and fuse combination devices
- GB2421.1 Overview and Guidelines for Environmental Testing of Electrical and Electronic Products
- GB14597 Climate and environmental conditions at different altitudes for electrical products
- GB/T2423.1 Environmental testing for electrical and electronic products - Part 2: Test methods - Test Ka: Low temperature
- GB/T2423.17 Environmental testing for electrical and electronic products - Part 2: Test methods - Test Ka: Salt spray

Our products have obtained 3C certificate.

- Recommended ambient air temperature limit is  $-40^{\circ}\text{C}\sim+70^{\circ}\text{C}$ , it can reach to  $+70^{\circ}\text{C}$  in a short time (within 24h).
- The altitude of the installation location is less than 5000m.
- Relative humidity: not exceed 50% at the maximum ambient temperature of  $+40^{\circ}\text{C}$ , but higher relative humidity at the lower temperature, for example, 90% at  $20^{\circ}\text{C}$ . Special measures should be taken considering the dew on product surface due to temperature change.
- Because the environment impact the switch's lifetime, the lifetime of switch should not exceed 10% of the nominal value at the  $-40^{\circ}\text{C}$  to  $-5^{\circ}\text{C}$ , and the operating frequency should no more than 1 time/3 minutes ; the switch lifetime of 100% of the nominal value, and an operating frequency of no more than once per minute at  $-5^{\circ}\text{C}\sim 50^{\circ}\text{C}$ ; the switch lifetime of 10% of the nominal value, and an operating frequency of no more than once per minute at  $50^{\circ}\text{C}\sim 70^{\circ}\text{C}$ . Test the temperature rise and dielectric properties after the operation
- Pollution grade 3.
- Usage category: DC-22A, DC-23A
- Salt spray: GB2423.18, severity level 2
- IV for main circuit and under-voltage release coil and power supply transformer primary coil; III for other auxiliary and control circuits.
- The vertical gradient: no more than  $5^{\circ}$ . It should be installed in an environment of without explosive hazards, conductive dust, and sufficient corrosion of metals and insulation damage.
- Transportation and storage conditions:  $-40\sim+75^{\circ}\text{C}$ .
- The protection level is IP30

Series

VW3GZ-16

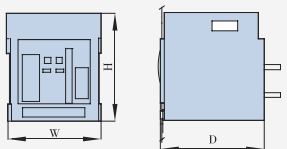

Rated current $I_n$ (A)			200, 400, 630, 800, 1000, 1250, 1600	
Rated working voltage $U_e$ (V)50Hz/60Hz			DC1000	DC1500
Rated insulation voltage $U_i$ (V)			1600	
Rated impulse withstand voltage $U_{imp}$ (kV)			12	
Number of poles			3P	4P
Rated short circuit making capacity (peak value) $I_{cm}$ (kA)			55	
Rated short-time withstand current (effective value) $I_{cw}$ (kA) 1s			55	
Electrical life (times)			500	500
Operating performance	Mechanical life (times)	Without maintenance	10000	
		Maintenance	10000	
Operational condition	Utilization category		DC22/23A	
	Pollution degree		3	
	Protection grade		IP30	
	Ambient temperature		-40~75°C	
	Altitude		≤5000m	
Outline dimension(mm)		Fixed type 2p	/	
(H x W x D)		Fixed type 3p	335×266×250	
		Fixed type 4p	335×336×250	

Note: Refer to the temperature derating table for specific requirements."

## Model Explanation and Encoding Rules

VW3GZ - □ □ / □ □ / □ □ / □ □ / □ □ / □ □ / □ □ / □ □ / □ □ / □ □

1 2 3 4 5 6 7 8 9 10 11 12 13 14 15 16

SN	Name	Specification, type code	Description	
1	Design code	VW3GZ: Design code	/	
2	Frame rating	16: 1600A	/	
3	Breaking type	Empty: Standard breaking level	/	
4	Rated current	02: 200A; 04: 400A; 06: 630A; 08: 800A; 10: 1000A; 12: 1250A; 16: 1600A	/	
5	Installation mode	F: Fixed type;	/	
6	Number of poles	3: 3P; 4: 4P	/	
7	Electric energy storage mechanism	D1:AC400V; D2:AC230V/DC220V; D4: AC/DC110V; D5:DC24V	/	
8	Shunt release	F1:AC400V; F2:AC230V/DC220V; F4: AC/DC110V; F5:DC24V	/	
9	Closed electromagnet	B1:AC400V; B2:AC230V/DC220V; B4: AC/DC110V; B5:DC24V	/	
10	Under-voltage release / Loss of voltage release / Voltage-check release	Under-voltage release	Q1: AC400V; Q2: AC230V; Q5: DC24V	1. Choose one from the Under-voltage release, Loss of voltage release, Voltage-check release;
		Loss of voltage release	S1: AC400V; S2: AC230V	
		Voltage-check release	J1: AC400V; J2: AC230V	
11	Under-voltage release / loss of voltage release Delay time	0: Instantaneous; 1: 1s delay; 3: 3s delay; 5: 5s delay	/	
12	Auxiliary contact	A33: 3NO3NC; A44: 4NO4NC; ... ; A1414: 14NO14C	/	
		A3: Three-group switching; A4: Four-group switching; ...; A14: Fourteen-group switching	/	
13	Internal Accessories	BX: Closing ready signal output unit	/	
14	External accessories	M: Doorframe Note: standard	/	
		S: Button lock	/	
15	Wiring mode	C1: Horizontal wiring; C2:Vertical wiring	/	
		1: Standard wiring	/	
16	Language type	Empty: Chinese; Y: English	/	

## Interlocking Piece Model Explanation and Encoding Rules

Key lock	SF11: Key lock device (one lock and one key) SF21: Key lock device(two locks and one key) SF22: Key lock device (two locks and two keys) SF31: Key lock device(three locks and one key) SF32: Key lock device (three locks and two keys) SF53: Key lock device(five locks and three keys)	Select one from six key locks;
Mechanical interlocking	SR11: Mechanical interlocking device (two sets of steel cables,one for closing and one for opening)	Select one from four key interlocks;
	SR12: Mechanical interlocking device (three sets of steel cables,one for closing and two for opening)	
	SR21: Mechanical interlocking device (three sets of steel cables,two for closing and one for opening)	
	SY11: Mechanical interlocking device (two sets of hard rods,one for closing and one for opening)	

# Installation of DC Disconnector

## Installation of Fixed DC Disconnector

Put the DC disconnector in the switchgear.

DC Disconnector	Hexagon-headed bolt GB5783-	Nut GB6170-	Washer GB97 GB93-
VW3GZ-16	M6 × 25	M6	Φ 6

Specific installation method and positions shown on the right.

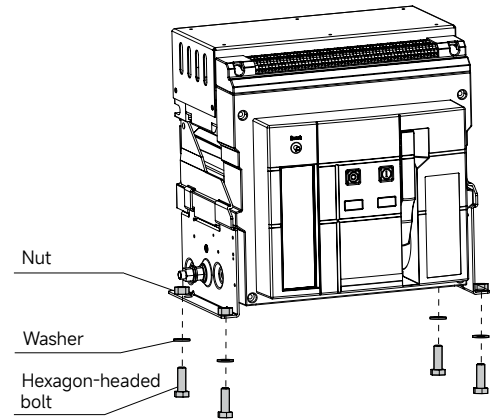

## Connection of Ground Terminal

It should be cleaned before grounding of the fixed type DC disconnector. And connect the PE wire to grounding bar of the switchgear by M12.

The area of wire refers to the following table.

Cross-sectional area of phase wire (mm <sup>2</sup> )	Corresponding protective conductor (minimum cross-sectional area of PE (mm <sup>2</sup> ))
35 < S ≤ 400	S/2
400 < S ≤ 800	200
S > 800	S/4

## Derating Coefficient

If the ambient temperature is higher than +40°C, capacity can be corrected according to the following table

Type	Rated current (A) In	+40°C	+45°C	+50°C	+55°C	+60°C	+65°C	+70°C
VW3GZ-16	200-1250	1	1	1	1	1	1	1
	1600	1	1	1	1	0.98	0.93	0.87

Note: The above data is calculated based on experiments and theories, and only for guidance and recommendations.

If the altitude exceeds or equals to 2000m, the electric property can be corrected according to the following table;

Altitude (m)	2000	3000	4000	5000
Power-frequency withstand voltage(V)	5000	4500	3500	2200
Rated current(A)	1.0In	0.9In	0.8In	0.6In
Rated working voltage(V)	DC1000 DC1500	DC1000 DC1500	DC1000 DC1500	DC1000 DC1500
Rated insulation voltage(V)	1600	1600	1600	1600

# Installation of DC Disconnect

## Copper busbar specification

Frame size rated current $I_{nm}$ (A)	Rated current $I_n$ (A)	Copper busbar specification		
		Number of busbar		Dimension
		Horizontal wiring	Vertical wiring	
VW3GZ-16	≤630	1		50×5
	800	1		50×10
	1000	1		50×10
	1250	2		50×10
	1600	2		50×10

Note 1: The table shows that the DC disconnect is installed in an open environment with a maximum ambient temperature of 40 °C and meets the copper bar specifications specified in GB/T 14048.3 for heating conditions. If the temperature exceeds 40 °C, the breaking capacity should be reduced or the number of copper bars should be increased.

Note 2: The maximum allowable temperature for copper bars should not exceed 110 °C.

## Recommended screw used of outlet busbar diameter

DC Disconnect type	Outlet busbar diameter	Screws grade 8.8 (with washer)	Tightening torque
VW3GZ-16	Φ11	M10	50N.m

## Wiring method for copper bars

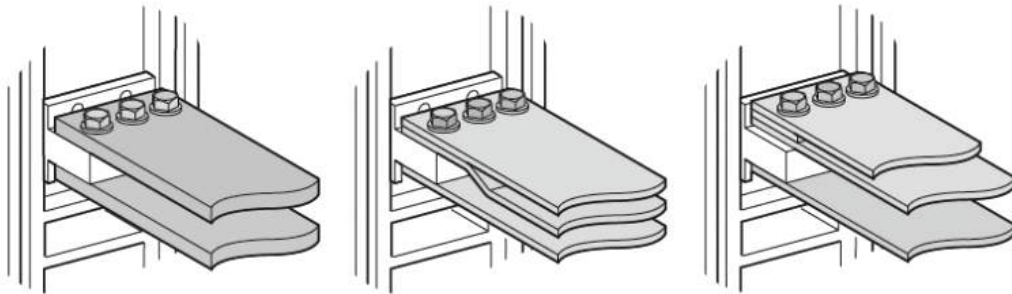

## Closed Electromagnet (B)

After storing energy, closed electromagnet may make the energy release instantly so that the DC disconnecter is closed quickly.



Power Consumption Table of Closed Electromagnet

Rated insulation voltage(Ui)	Rated control supply voltage(Us)	Closed current	Instantaneous power
		VW3GZ-16	VW3GZ-16
400V	AC380V/AC400V	1.5A	600W
	AC220V/AC230V	2.2A	500W
	DC220V	2.2A	500W
	DC110V	2.5A	270W
	DC24V	2.5A	60W
Operating voltage	(85%-110%)Us		
Minimum time of power on	100ms±10ms		
Action time (ms) Switching response time in Us	< 50ms		

## Shunt Release (F)

To break the DC disconnecter by remote control



Power Consumption Table of Shunt Release

Rated insulation voltage(Ui)	Rated control supply voltage(Us)	Closed current	Instantaneous power
		VW3GZ-16	VW3GZ-16
400V	AC380V/AC400V	1.5A	600W
	AC220V/AC230V	2.2A	500W
	DC220V	2.2A	500W
	DC110V	2.5A	270W
	DC24V	2.5A	60W
Operating voltage	(70%-110%)Us		
Minimum time of power on	100ms±10ms		
Action time (ms) Switching response time in Us	< 50ms		

## Accessories Installation of DC Disconnecter

### Motor operating mechanism (D)

The DC disconnecter has the function of motor driven energy storage and automatic energy restoring.  
(Manual energy storage can also be done)



Rated control supply voltage $U_s$ (V)	AC230	AC400	DC110	DC220	DC24
Operation voltage	(85%-110%) $U_s$				
Operating power	80VA		80W		
Starting power	400VA		400W		
Energy storage time(s)	≤5				
Motor type	Brush motor				

### Auxiliary contact



Rated insulation voltage (V)	400V				
Conventional thermal current	16A				
Usage category	AC-12	AC-15	DC-12	DC-13	
Rated working voltage	AC380	AC400	DC250	DC220	DC48
Rated working current	16A	3A	5A	1.2A	6A

Type	Code	Type	Code
3NO3NC	A33	4NO4NC	A44
5NO5NC	A55	6NO6NC	A66
7NO7NC	A77	8NO8NC	A88
9NO9NC	A99	10NO10NC	A1010
11NO11NC	A1111	12NO12NC	A1212
13NO13NC	A1313	14NO14NC	A1414

Note: 1. VW3GZ-16 series have 3NO 3NC~14NO 14NC  
 2. NO:normally open contact  
 3. NC:normally closed contact

## Undervoltage (loss-of-voltage) release (Q)



In the electrified networks where thunder and rain often happens or whose power supply is not stable, under-voltage release with time delay is highly recommended to protect the DC disconnector from releasing due to transient voltage-lowering. Time delay 1s,3s and 5s can be selected by the user. If there are some special requirements about time delay, please contact us.

Rated operational voltage (V)		Undervoltage release		Loss-of-voltage release	
		AC230	AC400	AC230	AC400
Action type	Type	Code			
	Instantaneous time	Q20	Q10	S20	S10
	Delay time 1s	Q21	Q11	S21	S11
	Delay time 3s	Q23	Q13	S23	S13
	Delay time 5s	Q25	Q15	S25	S15
Operation voltage (V)		(35%-70%) Ue		< 35%Ue	
Guarantee the reliable closing voltage (V)		(85%-110%) Ue			
Not guarantee the reliable closing voltage (V)		≤ 0.35%Ue			
Maintain power consumption(W)		4	3.27	3.5	3.3

## Phase separator

Phase separators are vertically installed between wiring boards of DC disconnecter which strengthen insulation.



## Lock

Off-position key lock (SF11, SF21, SF31, SF32, SF53, SF22)



Opening position lock can lock the OFF button of the DC disconnecter on the pressed position. After the opening position lock is chosen by the users, we would install and configurate.

Application method:

One lock one key (SF11): One DC disconnecter with one same lock and one key, and only allowed to closed when locked.  
Two locks one key (SF21): Two DC disconnecters with two same locks and one key, and only allowed one DC disconnecter closed.

Three locks one key (SF31): Three DC disconnecters with three same locks and one key, and only allowed one DC disconnecter closed.

Three locks two keys (SF32): Three DC disconnecters with three same locks and two keys, and only allowed two DC disconnecters closed.

Five locks three keys (SF53): Five DC disconnecters with five same locks and three keys, and only allowed three DC disconnecters closed.

Double interlock (SF22): With two different sets of keys and locks.

## Secondary Terminal



Item	Parameter
Connection method	Frame screw crimping
Standards	IEC60947-7-1
Screw diameter	M3
Torque	0.6-0.8 N.m
Flame grade	V0
Pollution degree	3
Material group grade	IIIa
Rated voltage	500V
Maximum load current	32A
Cross section of wire	0.2-2.5mm <sup>2</sup>
Recommends strip length	8mm

## Fixed type (VW3GZ-16, 200-1600A)

Front view

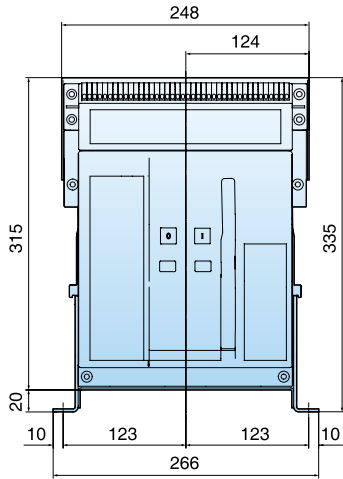

3 pole

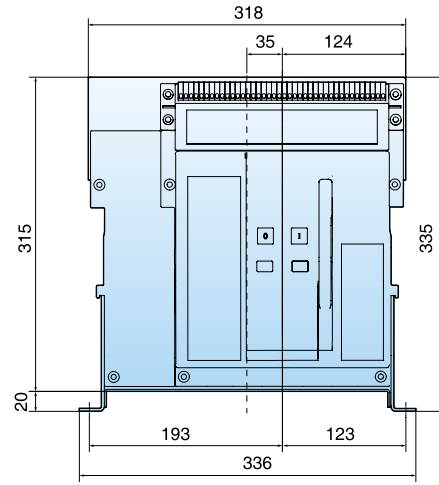

4 pole

Vertical Wiring

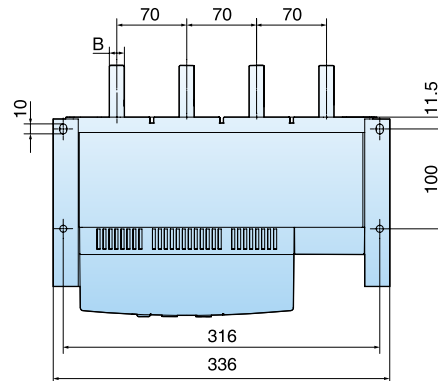
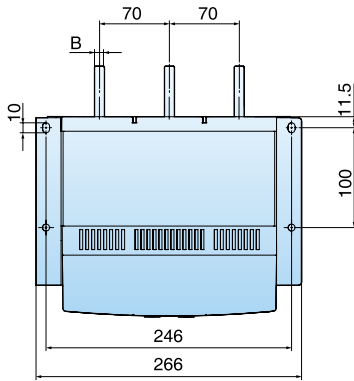

Distance for dismantling the arc extinguishing chamber

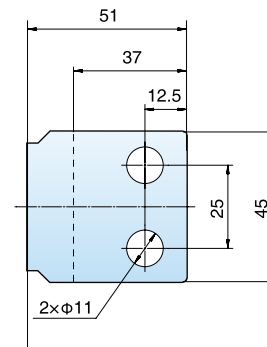
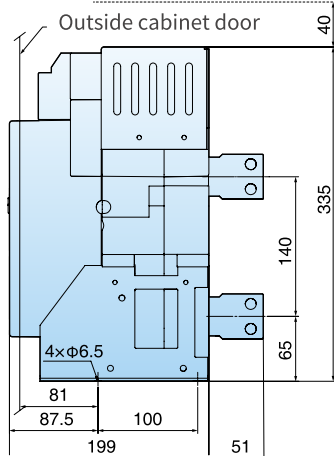

Current	VW3GZ-16 (200-1250A)	VW3GZ-16 (1600A)
Dimension B (mm)	10	15

# Size and Connection

## Horizontal Wiring

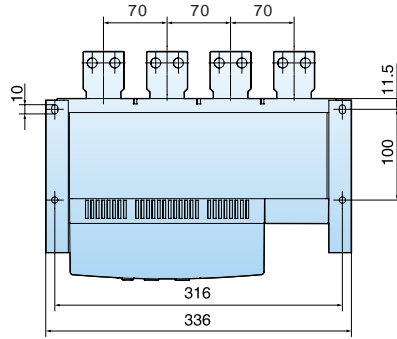
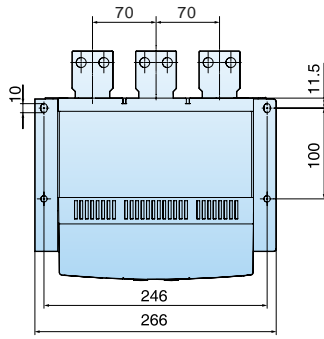

Distance for dismantling the arc extinguishing chamber

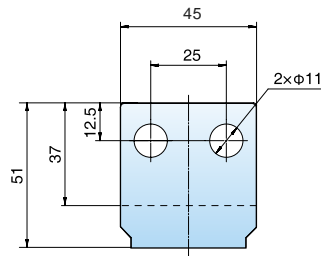
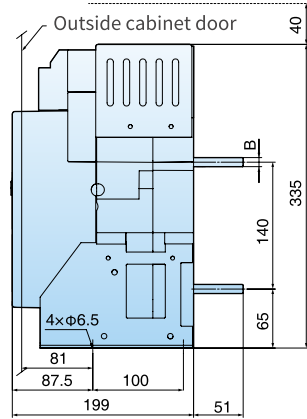

## Cabinet door open hole dimension

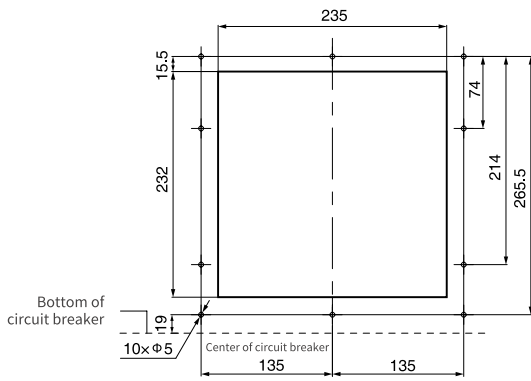

3P

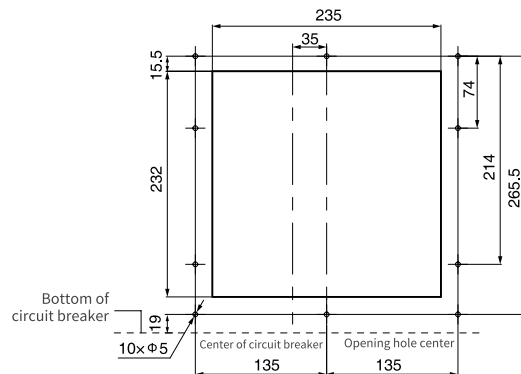

4P

## Size and Connection

When users install the DC disconnecter into the cabinet, the safe distance between the DC disconnecter and the cabinet is shown in the figure below, and the installation dimensions are shown in the table below.

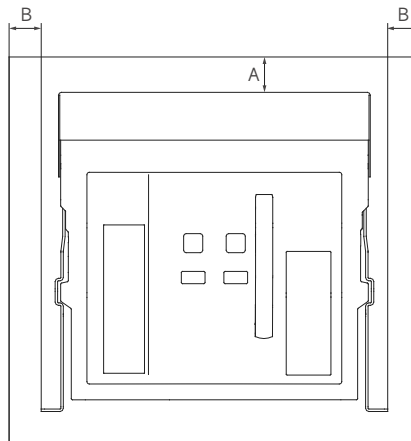

Fixed type DC disconnecter

unit: mm

Installation type of	To the insulator		To the metallic body grounded safely		To the live part	
	A	B	A	B	A	B
Fixed type	0	0	0	0	60	60

Note: The safety distance for fixed switches should consider a space of 40mm required to remove the arc extinguishing chamber;

## VW3GZ-16

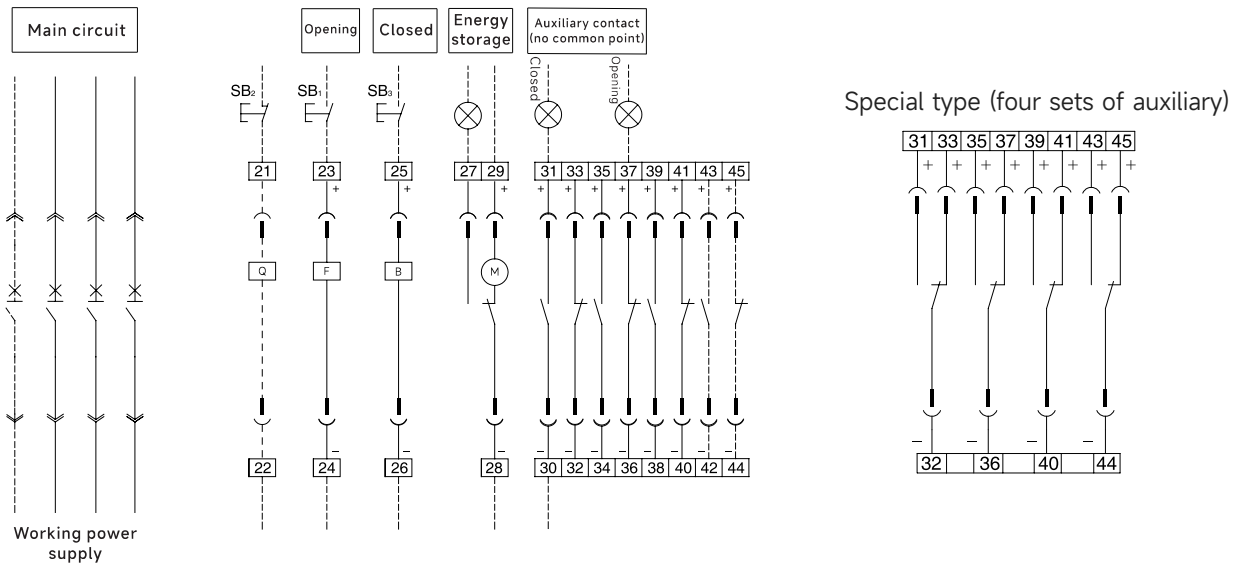

**Note:**  $SB_1$  Shunt button       $SB_3$  Close button       $F$  Shunt release  
 $B$  Closed electromagnet       $M$  Motor operating mechanism

### Terminal Number

21#, 22#	Under-voltage release or loss of voltage release
23#, 24#	Shunt release
25#, 26#	Closed electromagnet
27#, 28#, 29#	Motor operating mechanism
30#~45#	Auxiliary contact

### Note:

- 1) the Q, F, B, M can be with different power supply voltage;
- 2) Terminal 29# can be directly connected to the power supply (automatic pre energy storage), it can also be connected to the normally open button and then to the power supply (manually controlled pre energy storage);
- 3) The buttons and indicator should be provided by the user;
- 4) If the control power supply is DC, please connect the positive and negative wire

# Electrical Wiring Diagram

The selection of switchgear in DC systems mainly considers the following aspects:

- Rated working voltage, considering the number of series connected poles for disconnection
- Rated current, considering load power
- Grounding system method
  - a. Three pole series isolation switch - B-type wiring method
  - b. Four pole series isolation switch - C-type wiring method

## Recommended wiring method for VW3GZ DC disconnector

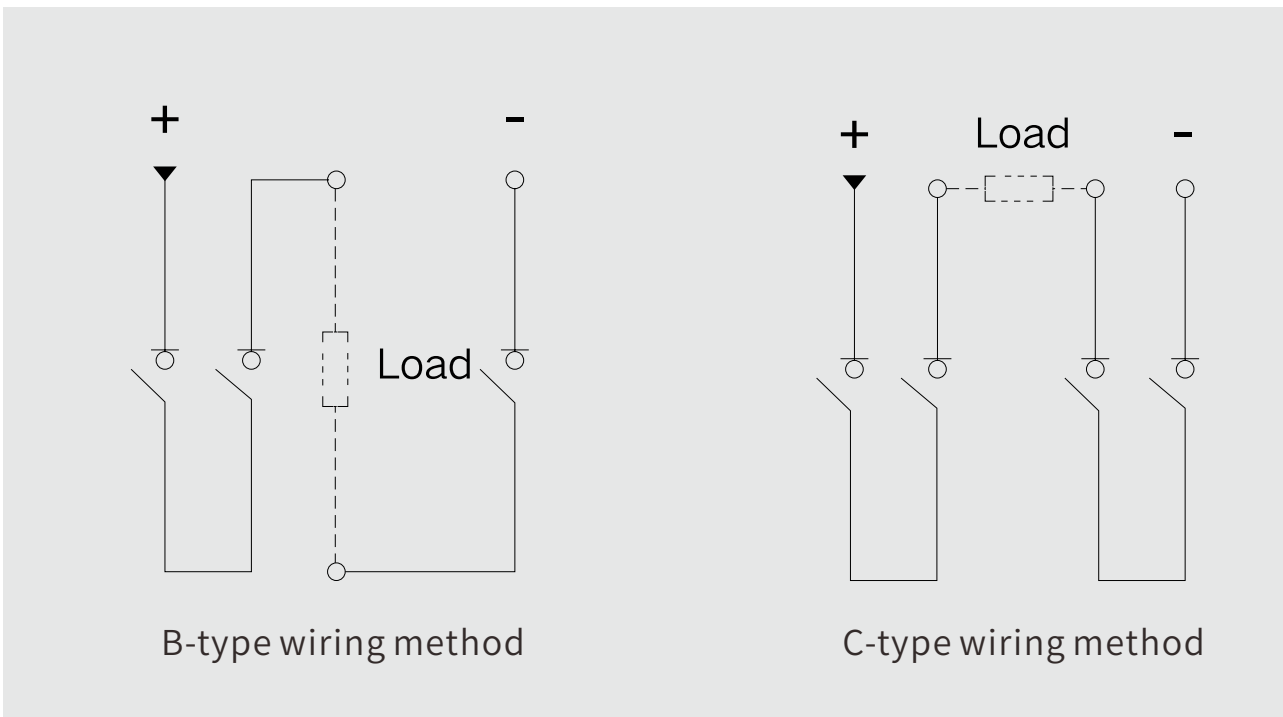

Note: If directly connected in parallel or series with the busbar, the continuous load of the isolating switch can only be 80% of the maximum operating current due to heating reasons. If parallel or series connections are made at a distance of 1 meter from the busbar, the DC disconnector can operate at full load.

### Installation employment warnings

1. Confirm that the specifications of the DC disconnecter meet the usage requirements before installation.
2. The product should be installed in a location that without of explosion hazards, conductive dust, and has no potential to damage metals or insulation.
3. During installation, forbidden other materials fall into the product.
5. Before installation, measure the insulation resistance of the isolation switch with a 500V megohmmeter. The insulation resistance should not be less than 500MΩ at an ambient air temperature of 20 °C± 5 °C and a relative temperature of 50% -70%. Otherwise, it should be dried until the insulation resistance meets the requirements before use.
6. During installation, the conductive busbar connected to the switch should be flat and free from additional mechanical stress.
7. During installation, the switch must be reliably grounded for protection, and there should be a clear grounding symbol at the grounding point.
8. After the installation, the following steps must be tested before the main circuit is powered on to ensure everything is normal before it can be officially powered on.
9. Carefully check for any other materials falling into the DC disconnecter, and if so, thoroughly remove them. The DC disconnecter must be kept clean.
10. Install the DC disconnecter according to the control circuit (secondary circuit) and connect it properly according to the wiring diagram. Check whether the working voltage of related components such as undervoltage/undervoltage, shunt release, closing electromagnet, energy storage motor, etc. matches the actual voltage, and then power on the secondary circuit. After the energy storage motor stores energy, press the closing button (electric or manual) to close the isolation switch.
11. Press the disconnect button (electric or manual) to open the DC disconnecter.
12. When manually storing energy, the handle on the front panel should be pulled up and down, and after seven times, the panel will display "Energy Storage". And hear a 'click' sound, the energy storage ends. If there is an undervoltage release at this time, power on (if not needed), and then perform the closing operation.

### Maintenance

- Every rotating part should be infused with lubrication oil periodically during using.
- Dust should be cleaned periodically so as to keep good insulation level of the DC disconnecter.
- Contacts system should be checked periodically you should check it after short circuit current breaking.

Contents to be checked:

- Whether the arc chute is in good condition
- Whether the contacts have good contact
- Whether fasteners of every connection part are in good connection

# Ordering Notes

Please fill in numbers in \_\_\_\_\_, and check ✓ in

User:		
Number of units ordered:		
Date of ordering:		
Basic parameters	Shell frame level	<input type="checkbox"/> VW3GZ-1600
	Installation mode	<input type="checkbox"/> F-Fixed type
	Rated current (A)	VW3GZ-1600 <input type="checkbox"/> 200 <input type="checkbox"/> 400 <input type="checkbox"/> 630 <input type="checkbox"/> 800 <input type="checkbox"/> 1000 <input type="checkbox"/> 1250 <input type="checkbox"/> 1600
	Breaking type	<input type="checkbox"/> Empty: Standard breaking level
	Number of poles	<input type="checkbox"/> 3-3P <input type="checkbox"/> 4-4P
	Wiring mode	VW3GZ-1600: <input type="checkbox"/> C1-Standard Horizontal wiring <input type="checkbox"/> C2-Standard Vertical wiring
Required accessories	Electric operating mechanism	<input type="checkbox"/> D1-AC400V <input type="checkbox"/> D2-AC230V/DC220V <input type="checkbox"/> D4-AC/DC110V <input type="checkbox"/> D5-DC24V
	Shunt release	<input type="checkbox"/> F1-AC400V <input type="checkbox"/> F2-AC230V/DC220V <input type="checkbox"/> F4-AC/DC110V <input type="checkbox"/> F5-DC24V
	Closed electromagnet	<input type="checkbox"/> B1-AC400V <input type="checkbox"/> B2-AC230V/DC220V <input type="checkbox"/> B4-AC/DC110V <input type="checkbox"/> B5-DC24V
Optional accessories	Under-voltage release	Voltage specifications <input type="checkbox"/> Q1-AC400V <input type="checkbox"/> Q2-AC230V <input type="checkbox"/> Q5-DC24V
		Delay time <input type="checkbox"/> 0-Instantaneous <input type="checkbox"/> 1-1s delay <input type="checkbox"/> 3-3s delay <input type="checkbox"/> 5-5s delay
	Loss of voltage release	Voltage specifications <input type="checkbox"/> S1-AC400V <input type="checkbox"/> S2-AC230V
		Delay time <input type="checkbox"/> 0-Instantaneous <input type="checkbox"/> 1-1s delay <input type="checkbox"/> 3-3s delay <input type="checkbox"/> 5-5s delay
	Voltage-check closing device	<input type="checkbox"/> J1-AC400V <input type="checkbox"/> J2-AC230V
	Auxiliary contact	<input type="checkbox"/> A33-3NO3NC <input type="checkbox"/> A44-4NO4NC <input type="checkbox"/> A55-5NO5NC <input type="checkbox"/> A66-6NO6NC <input type="checkbox"/> _____NO_____NC (Max. 14)
		<input type="checkbox"/> A3-Three-group switching <input type="checkbox"/> A4-Four-group switching <input type="checkbox"/> A5-Five-group switching <input type="checkbox"/> A6-Six-group switching <input type="checkbox"/> _____-group switching (Max. 14)
	Closing ready	<input type="checkbox"/> BX-Closing ready signal output unit
Door frame	<input type="checkbox"/> M-Door frame Note: standard	
Button lock	<input type="checkbox"/> S-Button lock	
Language type	<input type="checkbox"/> Chinese <input type="checkbox"/> Y-English	
Interlocking Off-position lock accessories	<input type="checkbox"/> SF11-Key lock device(one lock and one key) <input type="checkbox"/> SF21-Key lock device(two locks and one key) <input type="checkbox"/> SF31-Key lock device (three locks and one key) <input type="checkbox"/> SF22-Key lock device(two locks and two keys) <input type="checkbox"/> SF32: Key lock device(three locks and two keys) <input type="checkbox"/> SF53: Key lock device (five locks and three keys)	
Mechanical interlocking	<input type="checkbox"/> SR11-two sets of steel cables, one for closing and one for opening <input type="checkbox"/> SR12-three sets of steel cables, one for closing and two for opening <input type="checkbox"/> SR21-three sets of steel cables, two for closing and one for opening <input type="checkbox"/> SY11-two sets of hard rods, one for closing and one for opening	
Other requirements		