



## VM3 Series of Molded Case Circuit Breaker

### Product Specification

## 1. Application

The VM3 series of moulded case circuit breakers (referred to as circuit breakers) have a rated insulation voltage up to 1150V and apply to circuits with the AC 50Hz/60Hz, the rated working voltage AC800V or AC1000V. The circuit breakers are used for distributing power, solar energy ,wind power while protect the overload, short circuit and under-voltage (with a under-voltage release) of lines and power units as well as the infrequent starting, braking, overload and short circuit of motors.

The circuit breaker has an isolating function with the corresponding symbol of  Comply with standards: IEC60947-2, GB/T 14048.2.

- Tailored for photovoltaic and energy storage systems
- With higher breaking capacity
- With excellent anti damp heat and dew solidification capabilities
- Working voltage up to 1000V
- Strong ability to adapt to alternating changes in high and low temperatures
- High altitude adaptability

## 2. Picture of the product



### 3. Specification and model description

VM3	–	250	HU	M	250	/	TMF	/	3	/	AX/SHT
1		2	3	4	5		6		7		8
SN	Name		Specification, type code								
1	Design code		VM3: Design code								
2	Frame rating		250: 250A 630: 630A								
3	High voltage type		HU: Hight voltage								
4	Breaking capacity		L, M, H								
5	Rated current		63~400A								
6	Protection unit type		TMF: Thermal magnetic protection unit (For power distribution protection)								
7	Number of poles		3P								
8	Accessories (separated with"/" between different accessories)		Connection accessories				Empty: Fixed type wiring in front of the board				
			Electrical accessories				AL: Alarm contact AX: Auxiliary contact SHT: Shunt release UVT: Under-voltage release				
			Control Accessories Note: VM3-630HU optional				CD2: Motor operator CS1: Manual operator CS2: Manual operator-eccentric CS3: Box-type manual operator eccentric SF: Rotary handle F type SR: Rotary handle R type				

#### \* Electrical accessories

Accessories	Voltage				
SHT Shunt release	AC230V	AC400V	DC220V	AC/DC110V	DC24V
UVT Under-voltage release	AC230V	AC400V			
Motor operator	AC110V	AC230V	DC110V	AC/DC220V	DC24V

If the accessory voltage and voltage control loop is inconsistent, please use indicate the accessory voltage after accessory.

#### Example

VM3-250HUL250/TMF/3/AX/SHT (AC230)

Meaning: VM3 series circuit breaker; the frame level is 250A; breaking capacity is 30kA, 3 poles; rated current is 250A; fixed type wiring on front of the board; accessory contains auxiliary contact and shunt release with voltage (AC230V).

**Notice:** 1. HU type only provides front wiring of 3P.

4. Accessories

Electrical accessories (TMF)

Combined mode of electrical accessories

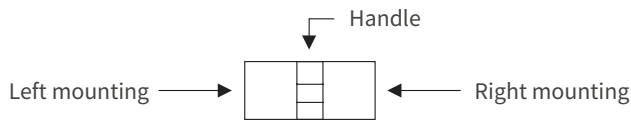

- Alarm switch
- Auxiliary switch
- Shunt release
- Under-voltage release
- Output lead direction

		Model	VM3-250	VM3-630
Accessory code	Accessory name	Poles	3	3,4 ①
AL	Alarm contact			
AX	Auxiliary contact			
SHT	Shunt release		② ③	② ③
UVT	Under-voltage release		/	② ③
SHT + UVT	Shunt release and under-voltage release		/	② ③
AL+AX	Alarm contact and auxiliary contact			
AL+SHT	Alarm contact and shunt release		② ③	② ③
AL+UVT	Alarm contact and under-voltage release		/	② ③
AX+SHT	Auxiliary contact and shunt release		② ③	② ③
AX+UVT	Auxiliary contact and under-voltage release		/	② ③
AX+AL+SHT	Auxiliary contact, alarm contact and shunt release		② ③	② ③
AX+AL+UVT	Auxiliary contact, alarm contact and under-voltage release		/	② ③

Note: 1.If there is need to learn about the instructions of installation of accessories of a 4 poles circuit breaker, please contact with the manufacturer;  
 2.If there is need for a UVT, a voltage module for the UVT is needed firstly(no voltage module is needed for a SHT ).  
 3.The standard installation of a SHT is the left pole installation, UVT is the right pole installation, please note if there is any special request.  
 4.AL module of a VM3-630 product is special supply for the right pole installation, please contact with the manufacturer

## Control accessories

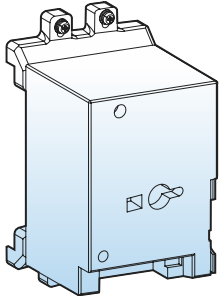

Motor-operated mechanism (CD2)

### Motor-operated mechanism (CD2)

Motor-operated mechanism which consists of an energy storage spring, an opening coil and a closing coil is used to control a circuit breaker from a distance. And a CD2 Motor-operated mechanism has the following features: CD2 type electric operating mechanism has

- The operation mode, manual or automatic mode, can be chosen.
- Hand drive handle is in front of a face cover.

The wiring diagram of a CD2 motor-operated mechanism is shown as following (internal accessories are indicated in the dotted square)

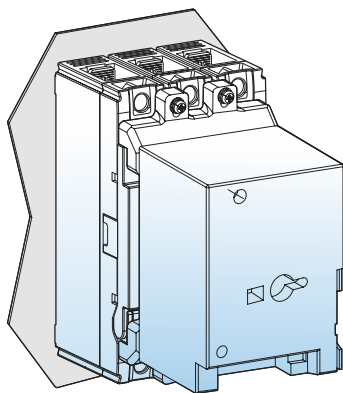
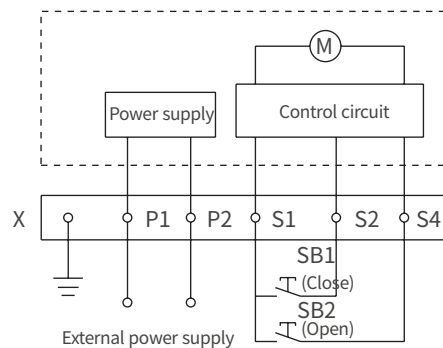

### Manual operation

- The internal power supply is automatically closed, if the switch is operated to "manual" position.
- Put the handle into the slot in the front of an electric operating mechanism and then turn in a clockwise direction.
- Do not turn it in a counterclockwise direction.

### Electric operation

- Auto connection
- Operating frequency should be no more than 3 times per minute.
- Using ON/OFF switches in the frequency range.
- Please do not input ON/OFF signal during automatic operation.
- Under-voltage release accessory(UVT) need to be applied a rated voltage before electric operation, if a Under-voltage release accessory(UVT) is mounted in a circuit breaker.

Motor-operated mechanism appearance

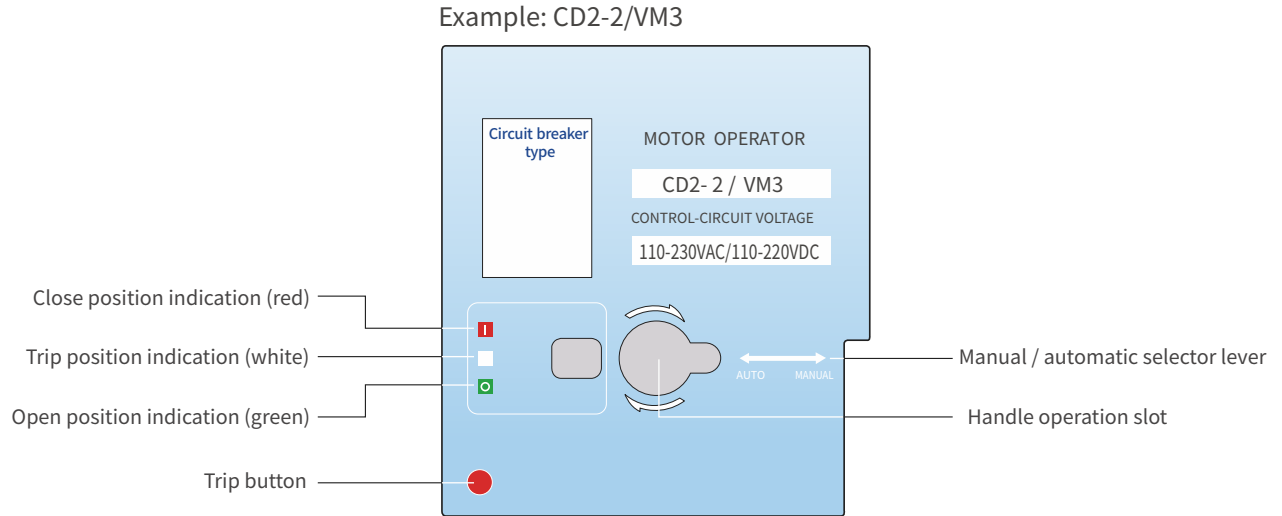

Acting Current, Motor Power and Longevity of CD2 type Power-driven Operating Mechanism

Equipped with circuit breaker type	Electric operating mechanism type	Control voltage	Starting current(A)	Response time(ms)		Power consumption	Durability
				Closed	Disconnect		
VM3-630 (Thermal-magnetic)	CD2-3	AC 110V/230V/400V DC 110V/220V/24V	≤ 0.5	500	350	14	10000

Note: After the circuit breaker trips,power-driven operating mechanism has to make the circuit reaker recrapped,then it can be turned on.

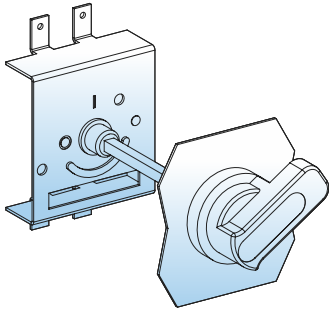

## Rotary handle operator (CS1, CS2, CS3) \*

With the unique design and transmission mechanism, the rotary handle operator can make the circuit breaker open, close and lock the tripping part by turning the handle.

Note: Rotary handle operator CS1, CS2, CS3 types details as P19 show

### CS series rotary handle operator has the following features:

- Equipped with circular and square rotary operating handles.
- The panel sheet of the cabinet cannot be opened when the circuit breaker is on (i.e interlock with the door).
- The handle can related supporting drawers, and interlock with the drawer unit.
- If fault of the operation handle occurs during its closing state, the panel sheet can be opened by operating the emergency reliever.
- Extended rotary handle can be used and the length of the extension handle is determined according to the distance between the rotary handle and the door. The shortest and the longest are 150mm and 500mm

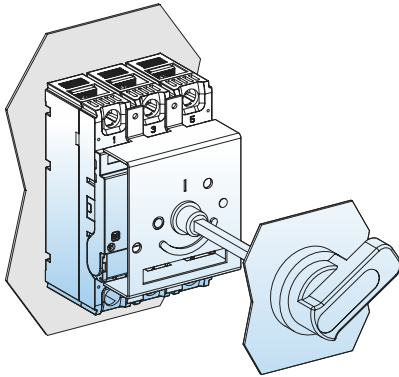

### Classification

The rotary handle mechanism contains central type and eccentric type.  
The rotary handle contains R type(circular) and F type(square).

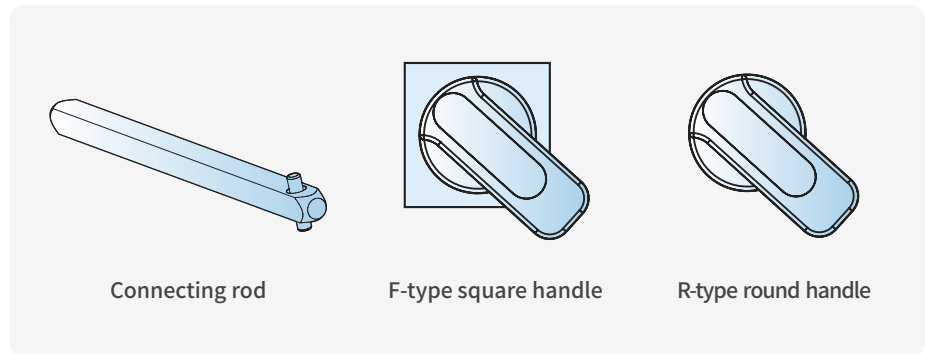
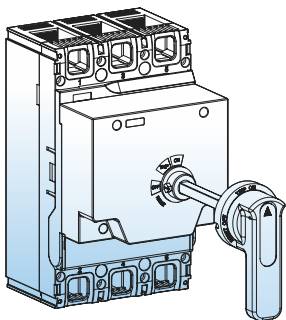

Connecting rod

F-type square handle

R-type round handle

## Insulation accessories

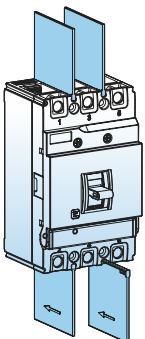

### Phase separator

- The insulation strength can be enhanced by phase separators.
- It can be installed from a slot of a switch after the switch is mounted.
- It can be used with all the other accessories except long and short covers.

## 5. Main Electrical Characteristics

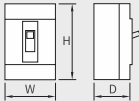
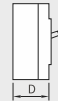
VM3 Series Molded Case Circuit Breaker (TMF)				VM3-250HUL	VM3-250HUM
Poles				3P	3P
Control	Rotary handle operator			■	■
	Motor-operated mechanism			■	■
Connection	Wiring in front of the board			■	■
	Wiring on back of the board			—	—
	Plug-in			—	—
	Draw-out			—	—
IEC 60947-2					
Release rated current $I_n$ (A)				63, 80, 100, 125, 140, 160, 180, 200, 225, 250	63, 80, 100, 125, 140, 160, 180, 200, 225, 250
Rated insulation voltage(V)			$U_i$	AC1150	AC1150
Rated impulse withstand voltage(kV)			$U_{imp}$	8	8
Rated operating voltage(V)			$U_e$	AC800	AC800/AC1000
Breaker Type				L	M
Rated ultimate short circuit breaking capacity(kA)	Icu	AC 50/60 Hz	400V	/	/
			500V	/	/
			690V	/	/
			800V	30	40
			1000V	/	15
Rated service short circuit breaking capacity(kA)	Ics	AC 50/60 Hz	400V	/	/
			500V	/	/
			690V	/	/
			800V	23	36.5
			1000V	/	15
Utilization category				A	A
Number of operation cycles	Machinery		10000	10000	
	Electrical	AC400V	/	/	
		AC500V	/	/	
		AC690V	/	/	
		AC800V	1500	1500	
AC1000V	/	1000			
Protection unit				Thermal-Magnetic	Thermal-Magnetic
Protection unit					
Overload protection	Long time delay	$I_r (I_n \times \dots)$	■	■	
Short-circuit protection	Instantaneous	$I_i (I_n \times \dots)$	■	■	
Indication and control accessories					
Alarm switch(AL)				■	■
Auxiliary switch(AX)				■	■
Shunt release(SHT)				■	■
Under-voltage release(UVT)				■	■
Installation					
Accessories	Terminal			■	■
	Phase separator			■	■
Outline dimension (mm) (H × W × D)					
			200 × 116 × 107	200 × 116 × 107	

**Note** : 1.HUL,HUM,HUH type only provides front wiring of 3P;

2.The symbol "-" indicates that this option is not available; The symbol "■" indicates that this option is optional.

# Main Electrical Characteristics

## VM3 Series Molded Case Circuit Breaker (TMF)

## VM3-250HUH

## VM3-630HUL



<b>Poles</b>			
Control	Rotary handle operator		
	Motor-operated mechanism		
Connection	Wiring in front of the board		
	Wiring on back of the board		
	Plug-in		
	Draw-out		
<b>IEC 60947-2</b>			
Release rated current $I_n$ (A)			
Rated insulation voltage(V)		$U_i$	
Rated impulse withstand voltage(kV)		$U_{imp}$	
Rated operating voltage(V)		$U_e$	
Breaker Type			
Rated ultimate short circuit breaking capacity(kA)	$I_{cu}$	AC 50/60 Hz	400V
			500V
			690V
			800V
			1000V
Rated service short circuit breaking capacity(kA)	$I_{cs}$	AC 50/60 Hz	400V
			500V
			690V
			800V
			1000V
Utilization category			
Number of operation cycles	Electrical	Machinery	
		Electrical	AC400V
			AC500V
			AC690V
			AC800V
AC1000V			
<b>Protection unit</b>			
Protection unit			
Overload protection	Long time delay	$I_r (I_n \times \dots)$	
Short-circuit protection	Instantaneous	$I_i (I_n \times \dots)$	
<b>Indication and control accessories</b>			
Alarm switch(AL)			
Auxiliary switch(AX)			
Shunt release(SHT)			
Under-voltage release(UVT)			
<b>Installation</b>			
Accessories	Terminal		
	Phase separator		
Outline dimension (mm) (H × W × D)			

3P
■
■
■
—
—
—
63,80,100,125,140,160, 180,200,225,250
AC1150
8
AC800
H
/
/
/
50
/
/
/
36.5
/
/
36.5
/
15
A
10000
/
/
/
1500
1000
Thermal-Magnetic
■
■
■
■
■
■
■
200 × 116 × 107

3P
■
■
■
—
—
—
200,250,315,350,400
AC1150
8
AC800/AC1000
L
/
/
/
36.5
/
/
/
36.5
/
15
A
10000
/
/
/
1500
1000
Thermal-Magnetic
■
■
■
■
■
■
■
257 × 150 × 103

**Note :** 1.HUL,HUM,HUH type only provides front wiring of 3P;

2.The symbol "—" indicates that this option is not available; The symbol "■" indicates that this option is optional.

## TMF Protection unit

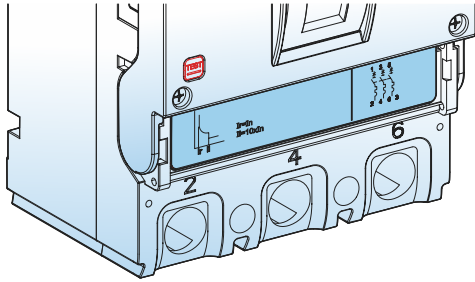

**TMF:** Thermal magnetic protection unit (For power distribution protection)

## TMF Sign interpretation

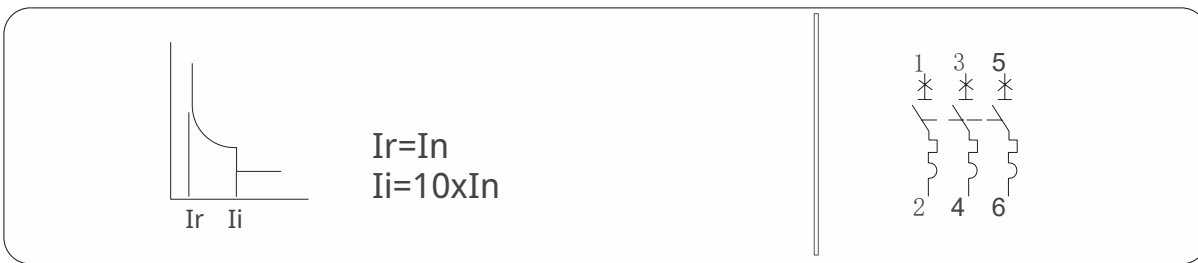

Protection curve

Protection unit type

## TMF Protection characteristics

TMF: Data sheet of protection characteristics

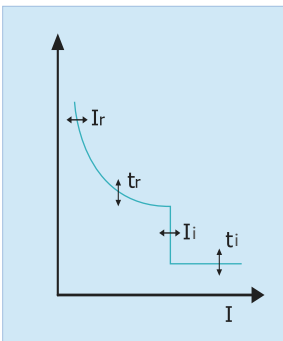

Rated current(A)	Inverse time acting characteristic (Ambient air temperature +40°C)		Instantaneous acting current(A)
	1.05In(Cold state) Not acting time	1.3In(Hot state) Acting time	
In ≤ 63	≥ 1h	<1h	10In±20%
63<In ≤ 800	≥ 2h	<2h	

## TMF Protection unit power loss

### Power loss

Circuit Breaker Model	Rated current(A)	Total power loss of three-phase(W)	
		Wiring in front of the board, Wiring on back of the board	Plug-in / Wiring on back of the board
VW3-250	250	35	40
VW3-630	630	43	51

### Derated coefficient of rated current

Circuit Breaker Model	+40°C	+45°C	+50°C	+55°C	+60°C	+65°C	+70°C
VM3-250	1.0 I <sub>n</sub>	1.0 I <sub>n</sub>	1.0 I <sub>n</sub>	1.0 I <sub>n</sub>	0.98 I <sub>n</sub>	0.95 I <sub>n</sub>	0.92 I <sub>n</sub>
VM3-630	1.0 I <sub>n</sub>	1.0 I <sub>n</sub>	1.0 I <sub>n</sub>	1.0 I <sub>n</sub>	0.97 I <sub>n</sub>	0.94 I <sub>n</sub>	0.91 I <sub>n</sub>

### Derated coefficient of high altitude of VM3 series MCCB

Item	Parameter						
Elevation	2000	2500	3000	3500	4000	4500	5000
Power frequency withstand voltage(V)	3000	3000	2500	2400	2200	2200	2200
Isolation voltage	1	1	0.95	0.91	0.87	0.87	0.87
Breaking capacity correction factor	1	1	0.95	0.91	0.87	0.80	0.74
Working current correction factor	1	1	0.98	0.97	0.96	0.95	0.94

### 6. Normal Working Environment of Circuit Breaker

- The altitude of the installation site doesn't exceed 5000m. See the above 'Derated coefficient of high altitude of VM3 series MCCB' table.
- Operating environment temperature:  $-40^{\circ}\text{C}\sim+70^{\circ}\text{C}$ , with an average value of no more than  $+35^{\circ}\text{C}$  within 24 hours. If the ambient temperature is higher than  $+40^{\circ}\text{C}$ , See the above 'Derated coefficient of rated current' table.
- Its relative humidity at an ambient temperature of  $+40^{\circ}\text{C}$  should not exceed 50%. A higher relative humidity is allowed at a lower temperature. For example, the relative humidity at  $20^{\circ}\text{C}$  can reach 90%; for frost due to temperature change, the corresponding measures should be taken.
- The product can withstand the effects of wet air, salt mist, oil mist and mould.
- The installation category of the circuit breaker connected to the main loop is: Category III (power distribution and control level), The installation category of the circuit breaker not connected to the main loop is: Category II (load level).
- The pollution level is Level 3.
- Degree of protection: IP 20.
- The product should be installed in places that are free from explosive media, media corrosive to metal, insulation damaging gas, and conductive dust, which should be also avoided from snow and rain.
- In case of stricter user conditions than the above description, negotiate with the manufacturer.

7. Thermal magnetic protection operating characteristic curve

Current-Temperature Characteristics

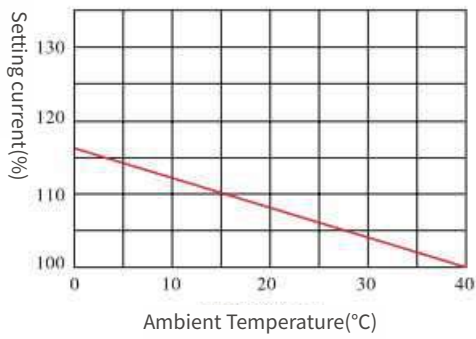

VM3-250 Time/Current Characteristic curve

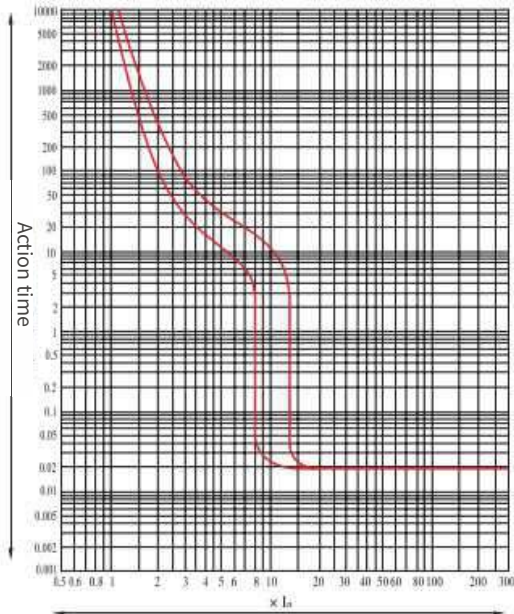

Current-Temperature Characteristics

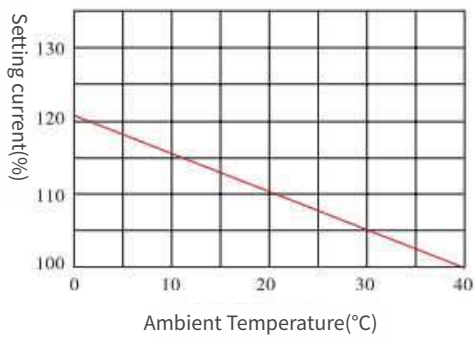

VM3-630 Time/Current Characteristic curve

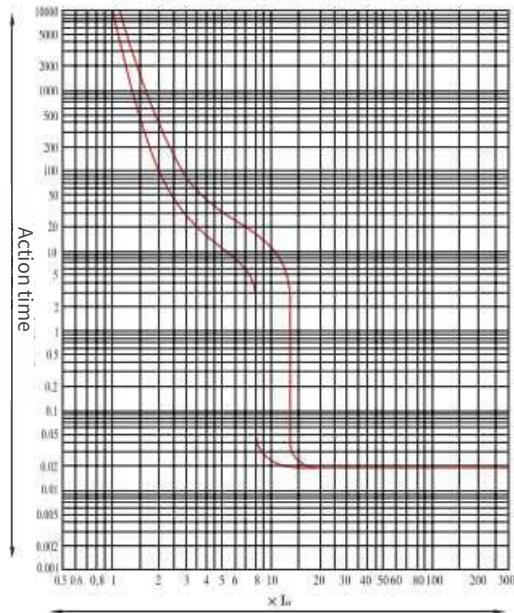

8. Size and Connection

VM3-250HU series dimensions and installation

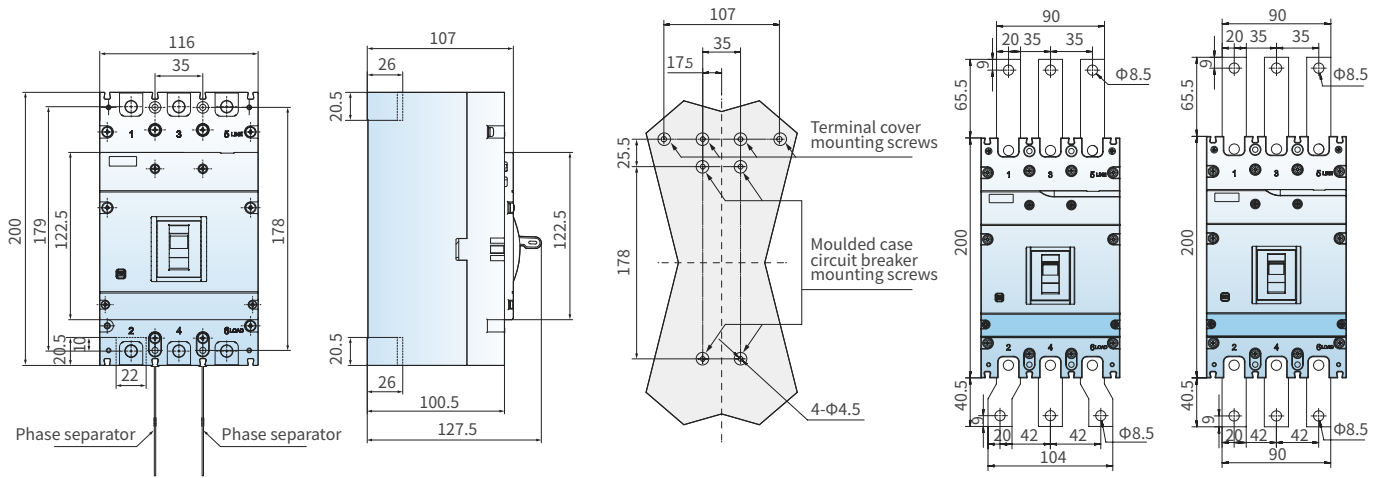

Note: Ensure the circuit breaker is fixed to the plate or the beam of the cabinet

VM3-250HU series dimensions with terminal cover

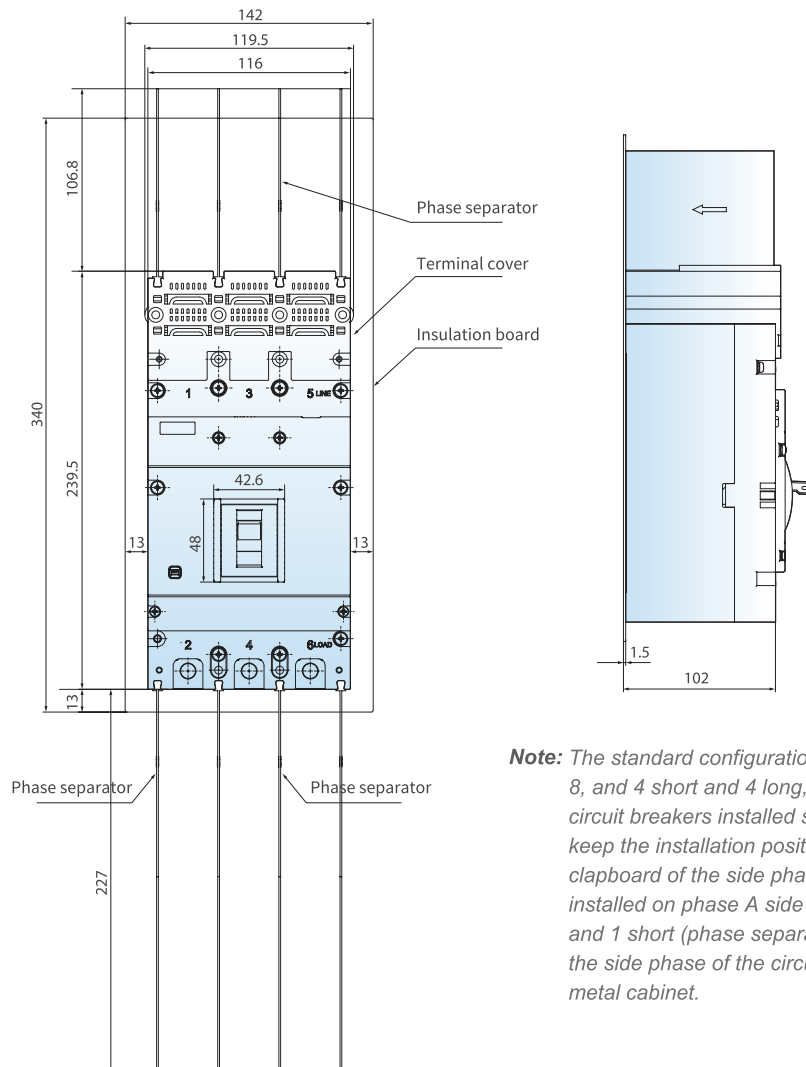

**Note:** The standard configuration of phase separators is 8, and 4 short and 4 long. When the number of circuit breakers installed side by side is  $\geq 2$ , please keep the installation position of the interphase clapboard of the side phase consistent (all installed on phase A side or phase C side), 1 long and 1 short (phase separator) should be added for the side phase of the circuit breaker close to the metal cabinet.



## Safety distance and installation diagram for VM3-250HU

The minimum spacing between adjacent circuit breakers

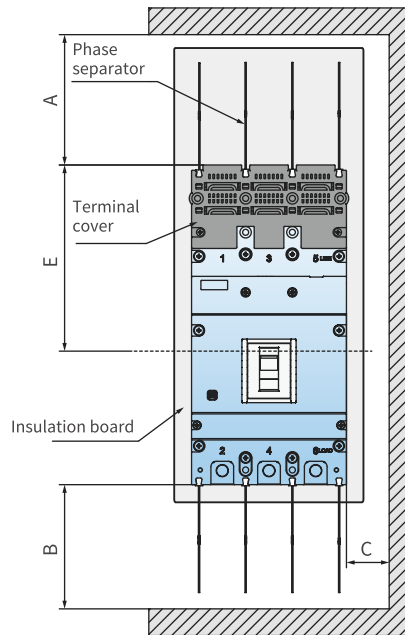
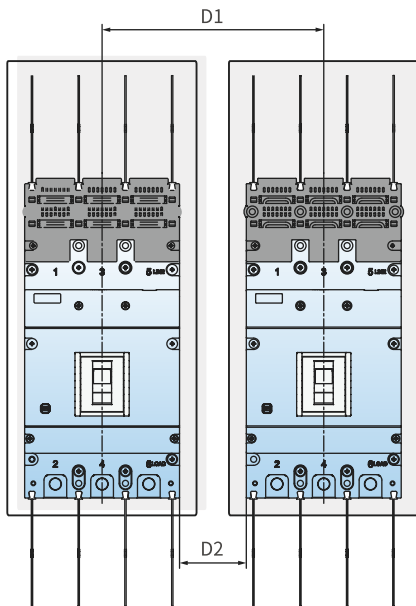

The minimum insulation length of wiring bar when it is front panel connection

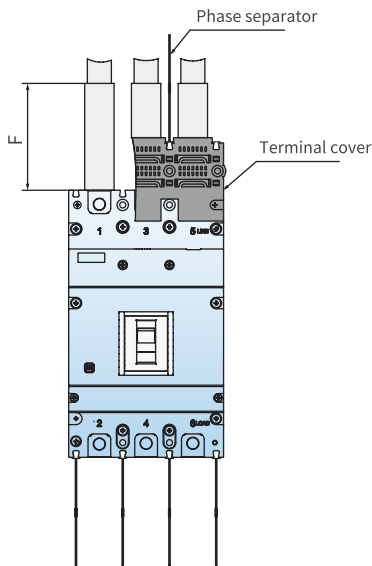

The minimum spacing between the circuit breaker and front panel

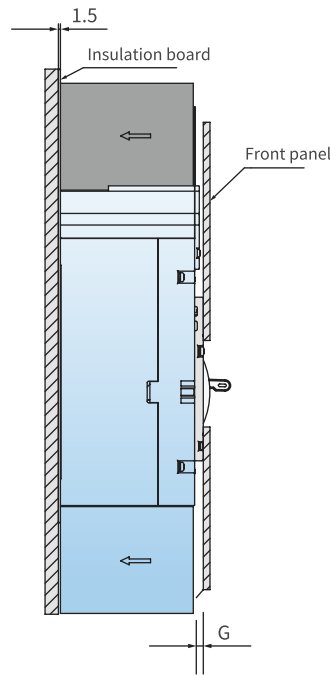

Model	Distance (mm)								
	A	B	C	D1	D2	E	F	G	
								Insulation board	Metal board
VM3-250HU	120	228	30	146	30	178.9	350	0	30

Note: When users use, terminal cover and phase separator should be assembled on terminals 1,3 and 5 of circuit breaker according to graphics. Phase separator should be assembled on terminals 2,4 and 6 of circuit breaker according to graphics. Insulation board is installed between circuit breaker and metal installation board.

Safety distance and installation diagram for VM3-630HU

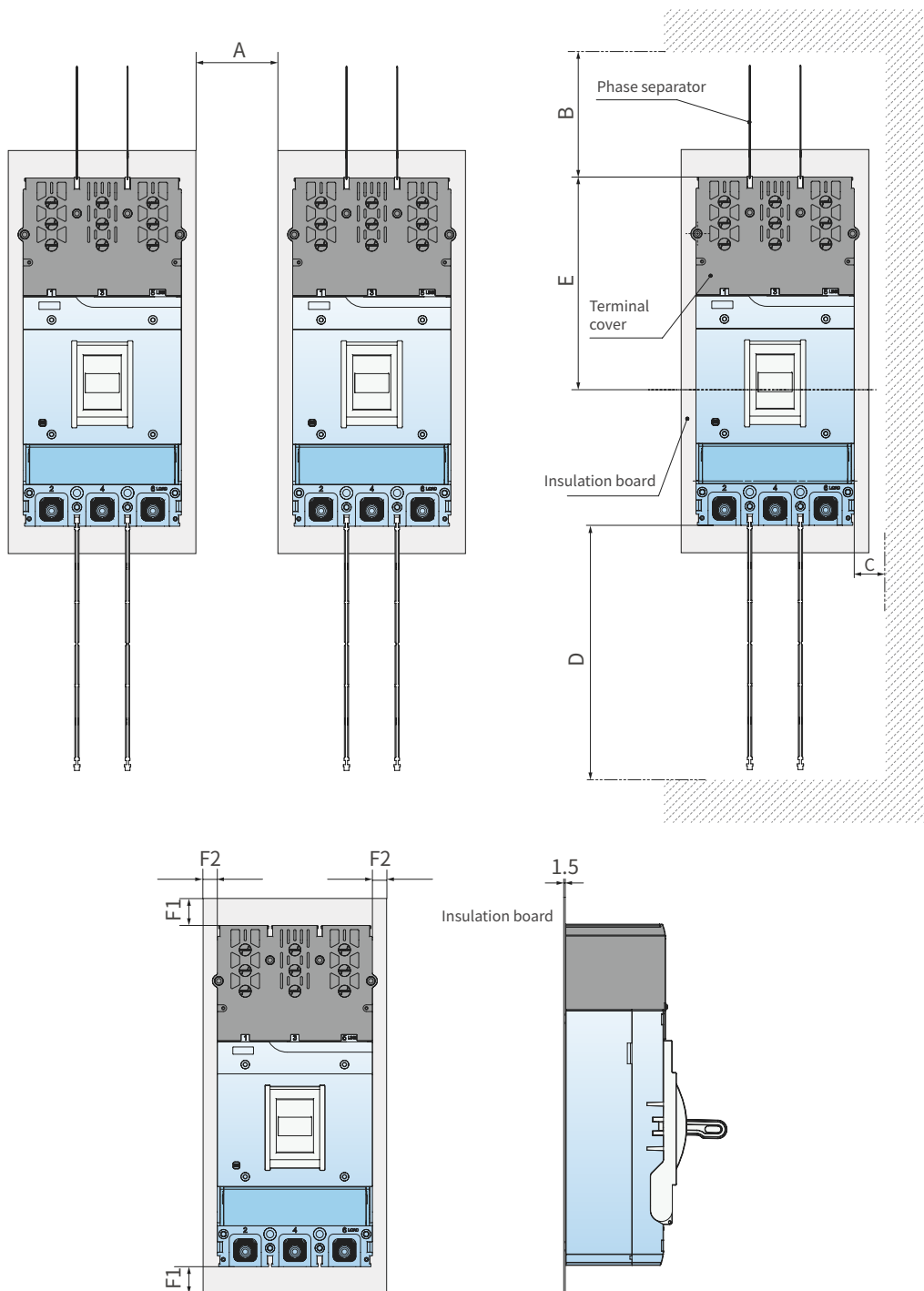

Model	A	B	C	D	E	F1	F2
VM3-630HU	30	150	30	180	201.5	26	14

Note: When users use, terminals 1,3 and 5 of the circuit breaker connect to transformer side and install terminal cover and phase separator according to graphics. Terminals 2,4 and 6 connect to inverter side and install phase separator according to graphics. Insulation board is installed between circuit breaker and metal installation board.

**Motor-operated mechanism**

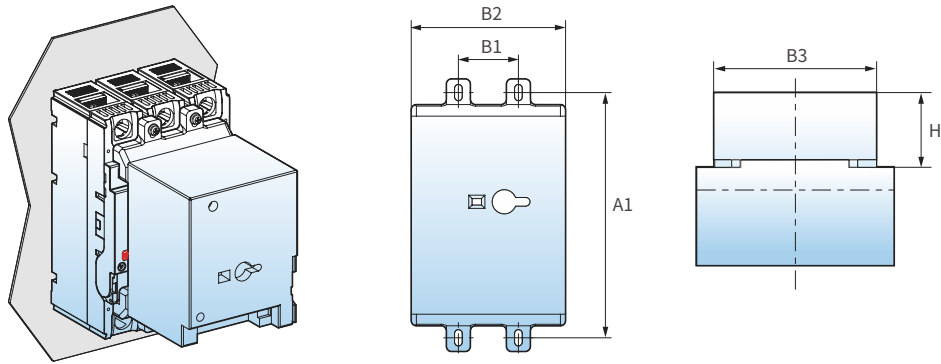

**Motor-operated mechanism dimension table**

Circuit breaker type	Motor operator model	A1	B1	B2	B3	H
VM3-630 (Thermal-magnetic)	CD2-3	194	48	129	175	156

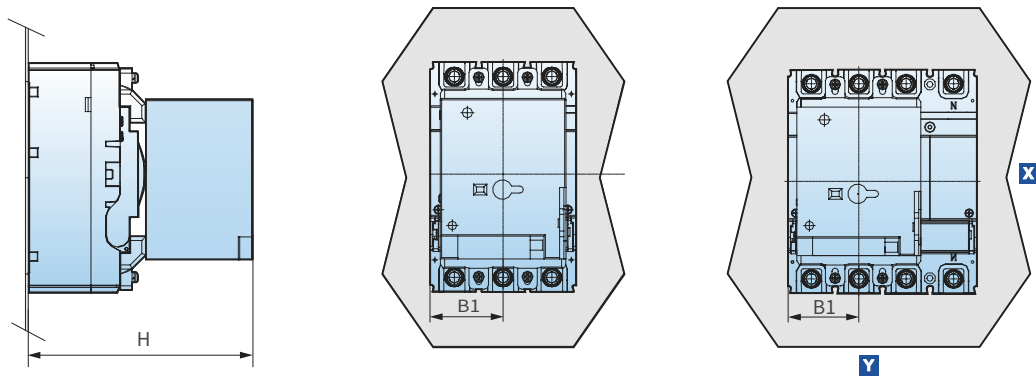

Model	B1	H												
VM3-630 (Thermal-magnetic)	75	250.5												

Extended rotary handle dimension

■ Centric

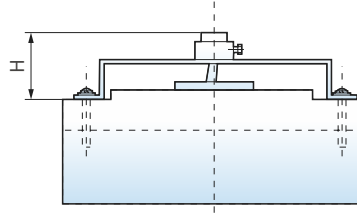
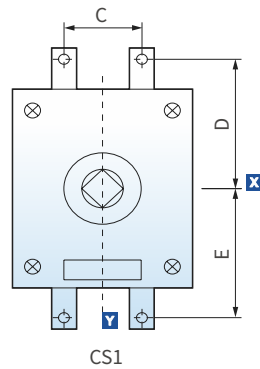

Horizontal and vertical mounting of circuit breaker

Centric size table

Model	Circuit breaker type	C	D	E	H	Remark
CS1-3	VM3-630 (Thermal-magnetic)	48	97	97	87	Used for vertical or horizontal installation of circuit breakers (centric trepanning)

■ Eccentric type

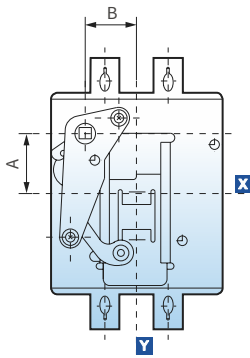

CS2-2

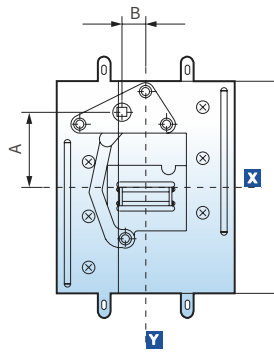

CS2-3

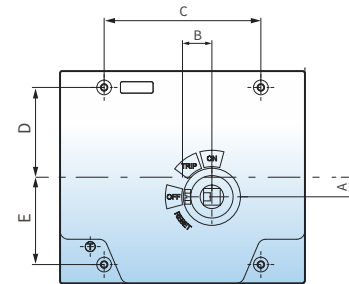

CS3-3

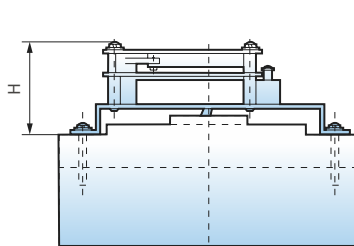

CS2

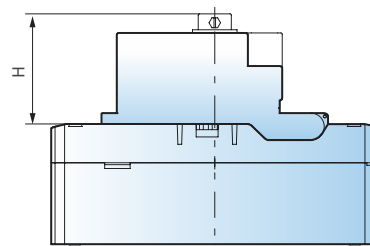

CS3

Eccentric size table

Model	Circuit breaker type	A	B	H	D	E	Remark
CS2-3	VM3-630 (Thermal-magnetic)	68	15	59	/	/	Used for vertical or horizontal installation of circuit breakers (eccentric trepanning)
CS3-3	VM3-630 (Thermal-magnetic)	12	18	86.5	55	53.5	

## Extended rotary handle installation

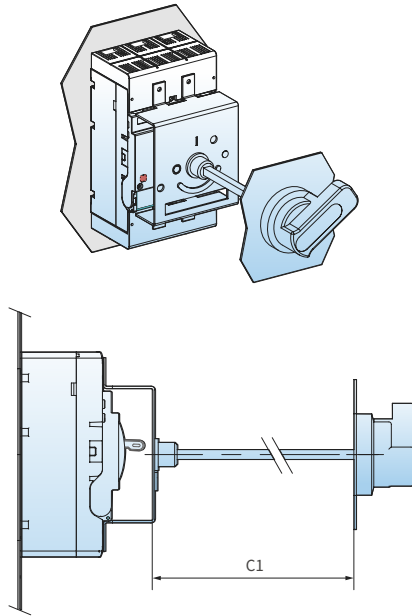

Circuit breaker model	C1	
	min	max
VM3-630	150	300

## Extended rotary handle installation

### Size and door sheet trepanning

F-type (F1 type used for VM3-250, F2 type used for VM3-630)

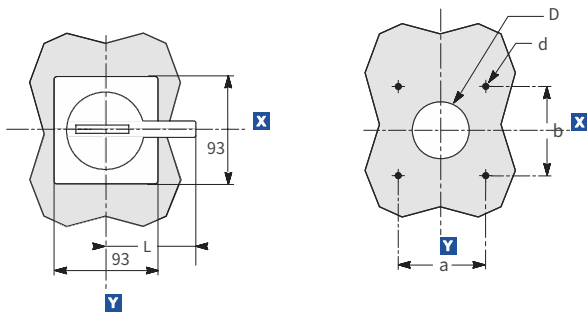

### F-type

F type handle mounting dimensions

Handle specifications	F1	F2
D	$\phi 42$	$\phi 42$
d	$\phi 4.5$	$\phi 4.5$
a	65	65
b	65	65
L	65	95

R-type (R1 type used for VM3-250, R2 type used for VM3-630)

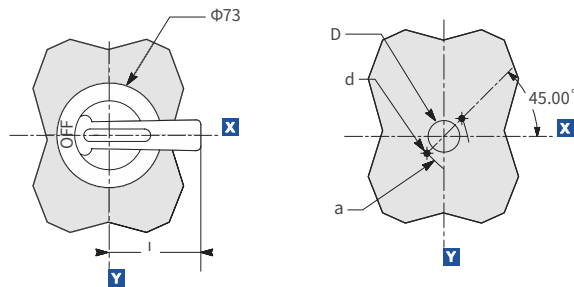

### R-type

R type handle mounting dimensions

Handle specifications	R1	R2
D	$\phi 34$	$\phi 34$
d	$\phi 5.5$	$\phi 5.5$
a	$\phi 53$	$\phi 53$
L	65	95

- Note: 1. The standard configuration of CS1 and CS2 type rotating handle is R type and the length of square shaft is 200mm which connects rotary handle and the operating mechanism. Please specify if you have special requirement.  
 2. For three pole and four pole circuit breakers, rotating handles have the same parameters.  
 3. VM3-250 hand aperture dimensions refers to F1, R1 and VM3-630 aperture dimensions refers to F2, R2.

9. Wiring diagram

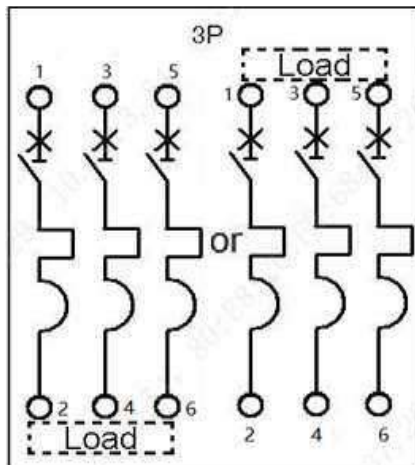

10. Accessory function description

Electrical accessories

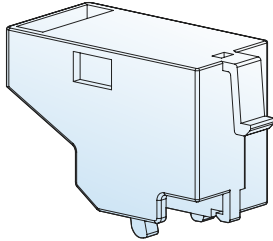

Alarm contact (AL)

Alarm contact (AL)

Function

The product outputs alarm signal when it is tripped by outer excitation signal due to overload, short circuit, undervoltage, or when the release button is pressed. This function is particularly useful in an automatic system, since that a fault signal can be sent to the designated place. And the fault signal will turn on due to an internal microswitch, when circuit breaker releases. But for normal opening or closing operations, it does not have any action.

Alarm contact operating characteristics

Circuit breaker status	Alarm contact status
The statuses of open and close	
The statuses of tripping	

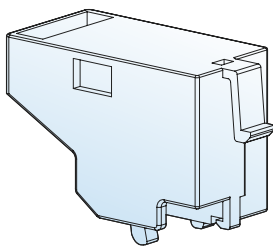

Auxiliary contact (AX)

Auxiliary contact (AX)

Function

Auxiliary switch is used for indication of remote "ON" and "OFF". Each switch contains two contacts, which share a common end of connection. The ON/OFF position depends on the state of main contact. When the circuit breaker is open, one of them is normally open, and the other is closed, or vice versa.

Auxiliary contact operating characteristics

Circuit breaker status	Auxiliary contact status
The statuses of open	
The statuses of close	

## Alarm contact, Auxiliary contact rated operational current

Classification	Rated current Inm	Conventional thermal current Ith(A)	Rated working current Ie(A)	
			AC400V	DC220V
Auxiliary contact	≤ 250	3	0.3	0.15
	400 ≤ Inm ≤ 1000	3	0.4	0.2
Alarm contact	10 ≤ Inm ≤ 1000	-	AC220V/1.0A	0.15

## ON-OFF capacity of Alarm contact and Auxiliary contact under normal conditions

Utilization category	ON				OFF				Number of operation cycles	Number of operation cycles per minute	Power time
	I/Ie	U/UE	cos φ	T <sub>0.95</sub>	I/Ie	U/UE	cos φ	T <sub>0.95</sub>			
AC-15	10	1	0.7	-	1	1	0.7	-	6050	6	≥ 0.05s
DC-13	1	1	-	6 × Pe	1	1	-	6 × Pe			≥ 0.05s

## ON-OFF capacity of Alarm contact and Auxiliary contact under abnormal conditions

Utilization category	ON				OFF				Number of operation cycles	Number of operation cycles per minute	Power time
	I/Ie	U/UE	cos φ	T <sub>0.95</sub>	I/Ie	U/UE	cos φ	T <sub>0.95</sub>			
AC-15	6	1	0.7	-	1	1	0.7	-	-	-	≥ 0.05s
DC-13	1.1	1.1	-	6 × Pe	1.1	1.1	-	6 × Pe	10	6	≥ 0.05s

Note: 1.  $T_{0.95}=6Pe$  is an empirical formula in which the unit of "Pe" is watt and the unit of  $T_{0.95}$  is millisecond.

2. The number of operation of Auxiliary contact can equal to that of the circuit breaker, if the number of operation of circuit breaker is less than 6050.

3. The operation frequency and power-on time of an auxiliary contact are allowed to be the same as those of the main circuit.

4. If  $T_{0.95}$  is more than 0.05s, the power-on time is at least  $T_{0.95}$ .

## Shunt release (SHT)

### Function

Shunt release refers to the device which disconnect circuit breaker with current from a distance. A shunt release can cut off the signal circuit automatically after tripping.

### Operating Characteristics

Voltage specification	AC50Hz: 110V 230V 400V DC: 24V 110V 220V
Operating characteristics	When the operation voltage is 70%~110% of the rated control voltage, the shunt release should trip the circuit breaker reliably.

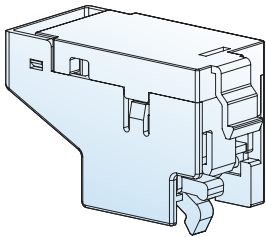

### Connection diagram (internal accessories of a circuit breaker)

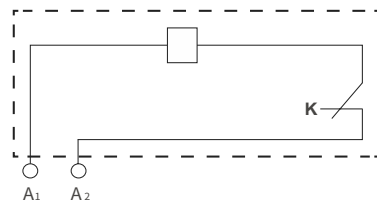

K is a microswitch closed contact of micro switch installed in series with the coil in shunt tripper, when the breaker is tripping, the switch is off by itself, when the breaker is closing, and then the switch is on.

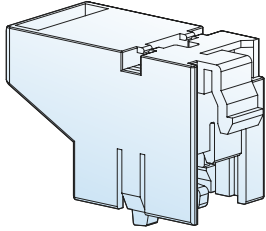

Under-voltage release (UVT)

### Under-voltage release (UVT)

#### Function

Under-voltage release is a device which can automatically disconnect the circuit breaker when voltage is reduced.

#### Operating characteristics of the under-voltage release

Rated operational voltage	AC400V AC230V
Operating Characteristics	<p>When the operation voltage is 70%~110% of the rated control voltage, the under-voltage should trip the circuit breaker reliably.</p> <p>When the working voltage is 85%~110% of the rated voltage, the under-voltage release should make the circuit breaker switch on.</p> <p>When the working voltage is less than 35% of the rated voltage, the under-voltage release should prevent the circuit breaker from being switched on.</p>

#### Wiring diagram of under-voltage release module (the internal accessories of circuit breaker are depicted in the dotted area)

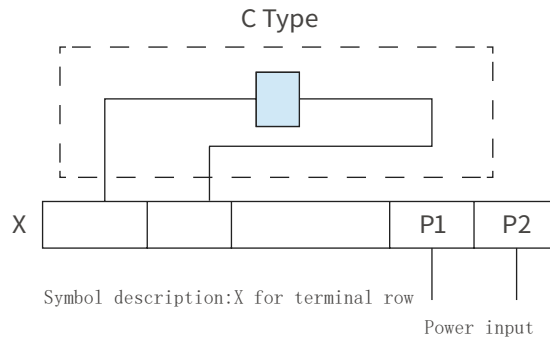

#### Under-voltage release power meter

Equipped with circuit breaker type	Under-voltage release power	
	AC230V	AC400V
VM3-630 (Thermal-magnetic)	0.75	0.75



*Before switch on a circuit breaker, the undervoltage release must be electrified otherwise the circuit breaker may be damaged.*

**11. Environment**

The environment that comply with RoHS instruction.

**12. List of installation accessories**

Accessories list form(VM3-250)

SN	Name	Specification	3P Quantity/Set
1	Cross small pan-head screw	M4×100	4
2	Hexagon nut	4	4
3	Plain washer	4	4
4	Terminal screw	M8×20	6
5	Terminal plain washer	8	6
6	Terminal spring washer	8	6
7	Terminal cover screw	M4×75	4
8	Terminal cover screw	M3×10	2
9	Phase separator	—	8
10	Insulating partition	—	1

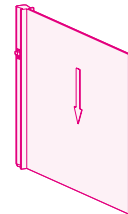
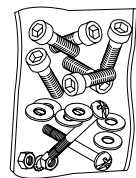

Accessories list form(VM3-630)

SN	Name	Specification	3P Quantity/Set
1	Cross small pan-head screw	M6 × 65	4
2	Hexagon nut	6	4
3	Plain washer	6	4
4	Terminal screw	M10 × 25	6
5	Terminal plain washer	10	6
6	Terminal cover screw	M4 × 50	4
7	Terminal cover screw	ST2.9 × 9.5C	2
8	Phase separator	—	4
9	Insulating partition	—	1

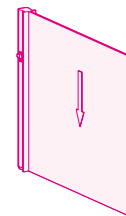
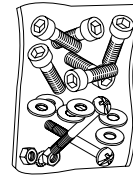

**13. Circuit breaker notes**

- Various characteristics and accessories of the circuit breaker are set in the factory. The circuit breaker, tripping unit or other accessories can only be adjusted, installed and maintained by the trained or qualified professionals according to the parameter requirements of the line design.
- Ensure that the power supply is off before installing or removing any device .
- The circuit breaker handle can be located in three positions, indicating three states on, off and free tripping. When the handle is in the free tripping position, pull the handle in the off direction when the circuit breaker is connected and on.