

**VOZWEI**

Application for  
**Solar Energy**  
**Wind Power**  
**Telecommunication**



**CIRCUIT BREAKER PRODUCT MANUAL**

# VOZWEI

## Brief Introduction

VOZWEI is a dual drive company driven by technology and client's demand, focusing on people's electricity safety and striving to contribute to the development of green energy. We specialize in the research and development, production, sales, and service of terminal electrical apparatus, electrical distribution apparatus, and control electrical apparatus, such as miniature circuit breakers, molded case circuit breakers, Air circuit breakers, DC contactors, and other electrical products.

Since its establishment, VOZWEI has adhered to the core value of "achieving clients" and driven product research and development based on client's needs. We focus on telecommunication, solar energy, and wind power applications, etc. relying on the manufacturing advantages of China's industry and the excellent cost control and quality management advantages of our team to achieve cost control for clients, while ensuring the business philosophy of providing high-quality electrical products and solutions. At present, our products have involved in dozens of countries and regions such as Germany, France, Italy, Britain, Brazil, Argentina, Colombia, Canada, Israel, Thailand, Vietnam, South Korea, India, etc.



**Telecom**



**Solar  
Energy**



**Wind  
Power**

## Corporate Cultures

### **Our Vision**

Pursuing excellence, creating the electrical future of a safer, more reliable and smarter

### **Our Mission**

Steady development, bring the electric products of premium quality at reasonable prices to world

### **Core values**

Value, Reliability, Efficiency, Innovation, Low-carbon, Vitality

### **Work Philosophy**

Relying on responsibility and diligence to aim at perfection, respect everyone, and happiness comes from striving

# Contents



## 01

### VW3

#### Air Circuit Breaker

---

Design Features	1-2
Selection Guide	1-3
Controller	1-12
Accessories	1-31
Main Characteristic	1-41
Size and Connection	1-42
Order Notes	1-67

## 02

### VW3GZ

#### DC Disconnect

---

Design Features	2-2
Selection Guide	2-3
Accessories	2-6
Main Characteristic	2-13
Size and Connection	2-14
Order Notes	2-25

## 03

### VM3

#### Molded Case Circuit Breaker

---

Design Features	3-2
Selection Guide	3-3
Main Characteristic	3-6
Accessories	3-8
Characteristics Curve	3-15
Size and Connection	3-16

## 04

### VM5

#### Molded Case Circuit Breaker

---

Design Features	4-2
Selection Guide	4-3
Main Characteristic	4-5
Accessories	4-6
Size and Connection	4-13

## 05

### VB2

#### Miniature Circuit Breaker

---

Design Features	5-2
VB2-63	5-3
VB2T-63	5-7
VB2TS-63	5-12
VB2Z-63	5-15

# VW3

Air Circuit Breaker





- Tailored for solar energy, wind power and energy storage systems
- High-voltage air circuit breaker, optional 800V AC, 1140V AC, 1250V AC, 1500V AC
- With ultra-high breaking capacity, max meet 85kA at 800V AC
- With excellent anti damp heat and dew solidification capabilities
- Strong ability to adapt to alternating changes in high and low temperatures
- Strong resistance to salt spray and humid environments
- High altitude adaptability, still safe working at an altitude of 5000 meters
- Can be used in complex mixed gas environments (Cl<sub>2</sub>, SO<sub>2</sub>, NO<sub>2</sub>, H<sub>2</sub>S)
- Low energy consumption and temperature rise of the product itself
- Integrated communication network, capable of remote control, telemetry, remote signaling, and remote adjustment

## Ambient conditions

---

### Operating ambient temperature/storage temperature

- Operating environment temperature:-40°C- +70°C

### Altitude conditions

- Altitude of installation site ≤ 5000m (Over 2000 meters need capacity reduction for using)

### Shockproof level

- Passed the impact test with a peak acceleration of 30g and three axes and six directions
- Passed the vibration test with an acceleration of 10g and a frequency of 10-200Hz
- Excessive vibration may cause component damage and affect the reliable operation of the circuit breaker

### Corrosion prevention

- Passed the C4-H level anti-corrosion test specified in ISO12944-6 and GB/T 30790.6-2014 standards

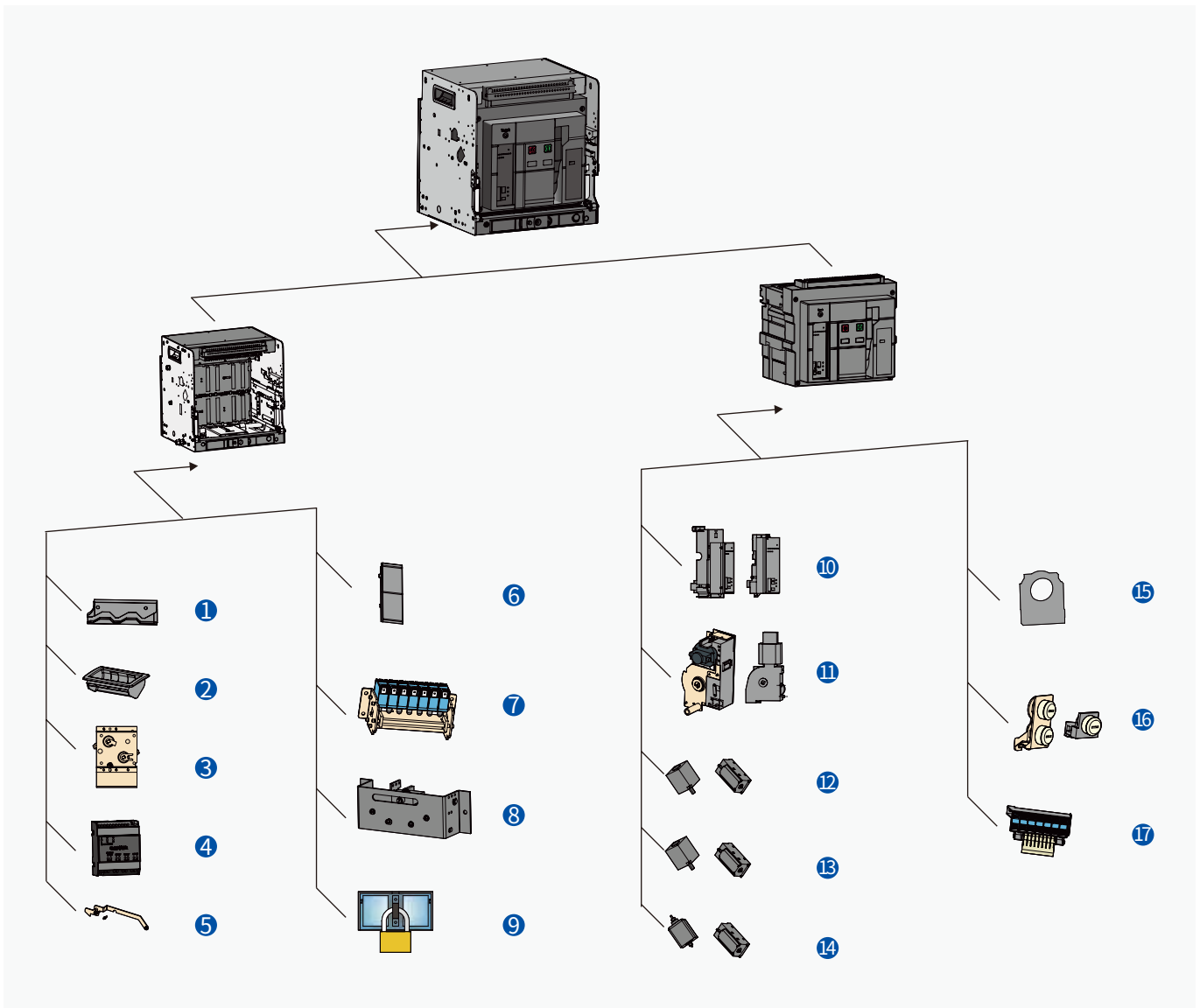

## VW3 Accessories

- |                           |                              |   |                       |
|---------------------------|------------------------------|---|-----------------------|
| ① Positioning component   | ⑥ Phase partition            | ⑪ Motor operating mechanism             | ⑯ Prevent closinglock |
| ② Sheath                  | ⑦ External auxiliary contact | ⑫ Shunt release                         | ⑰ Auxiliary contact   |
| ③ Mechanical interlocking | ⑧ Position indication        | ⑬ Undervoltage(loss of voltage) release |                       |
| ④ Power supply module     | ⑨ Button lock                | ⑭ Closed electromagnet                  |                       |
| ⑤ Door interlocking       | ⑩ Controller                 | ⑮ External transformer                  |                       |

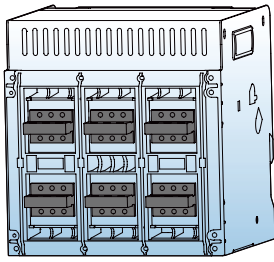

Horizontal Wiring C1

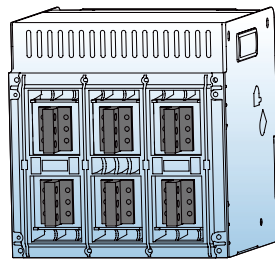

Vertical Wiring C2

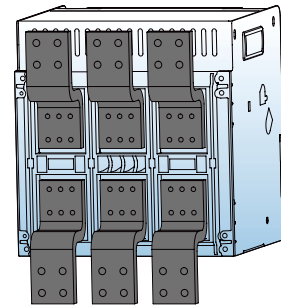

Forward Wiring C3

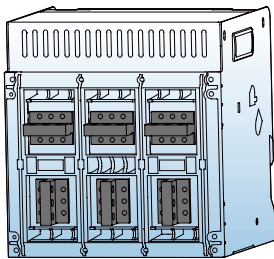

Mixed Wiring C4  
(Upper Horizontal, Lower Vertical)

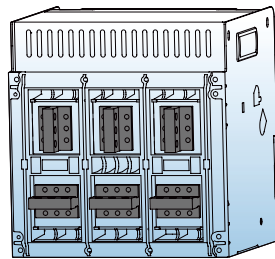

Mixed Wiring C5  
(Upper Vertical, Lower Horizontal)

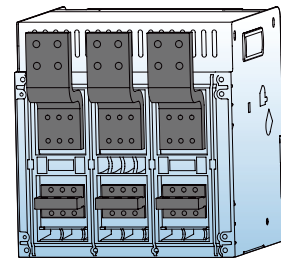

Mixed Wiring C6  
(Upper Forward, Lower Horizontal)

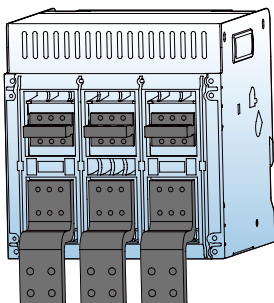

Mixed Wiring C7  
(Upper Horizontal, Lower Forward)

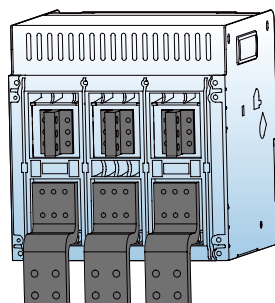

Mixed Wiring C8  
(Upper Vertical, Lower Forward)

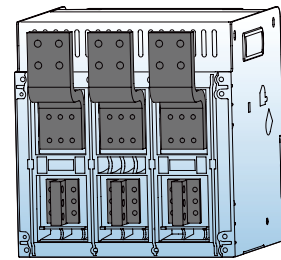

Mixed Wiring C9  
(Upper Forward, Lower Vertical)

Wiring mode	VW3-20	VW3-25	VW3-40		VW3-63
			1000~3200A	3600~4000A	
Horizontal Wiring	●	●	●	●	●
Vertical Wiring	○	—	○	○	—
Forward Wiring	—	—	○	—	—
Mixed Wiring (Upper Horizontal, Lower Vertical)	○	—	○	○	—
Mixed Wiring (Upper Vertical, Lower Horizontal)	○	—	○	○	—
Mixed Wiring (Upper Forward, Lower Horizontal)	—	—	○	—	—
Mixed Wiring (Upper Horizontal, Lower Forward)	—	—	○	—	—
Mixed Wiring (Upper Vertical, Lower Forward)	—	—	○	—	—
Mixed Wiring (Upper Forward, Lower Vertical)	—	—	○	—	—

Note: ● standard wiring, ○ optional wiring, — without wiring

## Fixed type



- ① Secondary wiring chart
- ② Controller
- ③ Nameplate
- ④ Fixed bracket
- ⑤ Grounding bolt
- ⑥ Secondary wiring terminal
- ⑦ Drawer seat
- ⑧ Reset button
- ⑨ Disconnection button
- ⑩ Closing button
- ⑪ Manual energy storage handle
- ⑫ Energy releasing and storing indication
- ⑬ Disconnection and closing indication
- ⑭ Three position indication
- ⑮ Unlocking button
- ⑯ Separation position locking device

## Drawout type

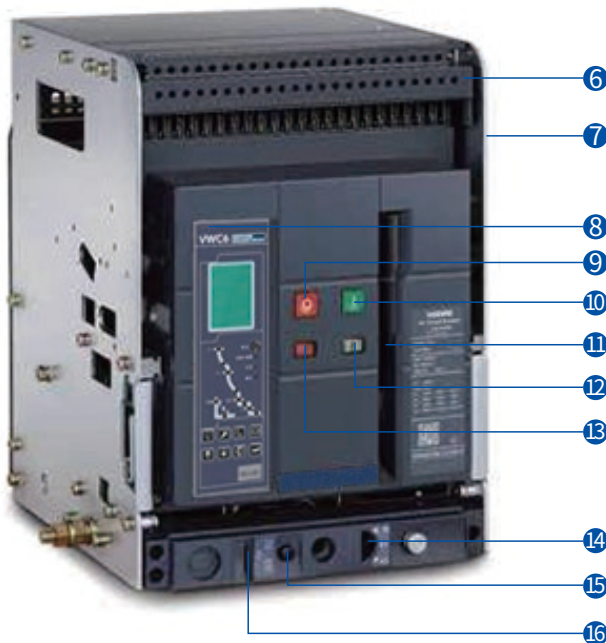

- ⑥ Secondary wiring terminal
- ⑦ Drawer seat
- ⑧ Reset button
- ⑨ Disconnection button
- ⑩ Closing button
- ⑪ Manual energy storage handle
- ⑫ Energy releasing and storing indication
- ⑬ Disconnection and closing indication
- ⑭ Three position indication
- ⑮ Unlocking button
- ⑯ Separation position locking device

## Drawer seat

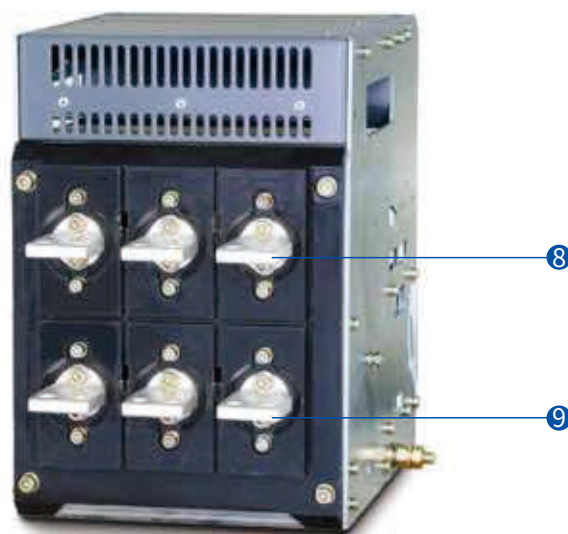
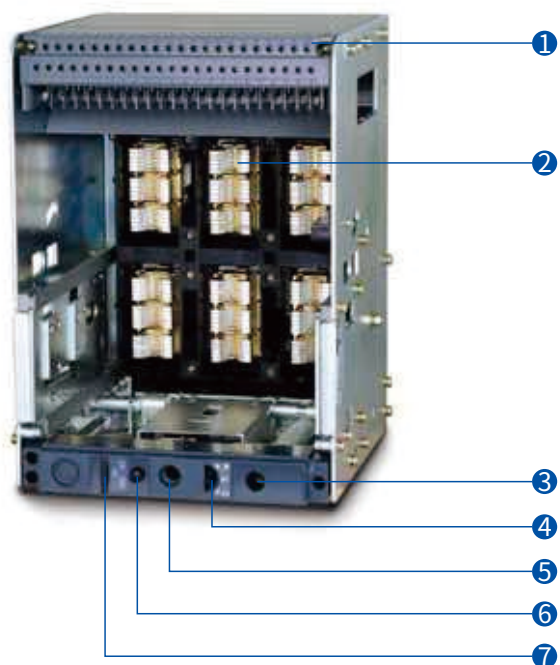

- ① Secondary wiring terminal
- ② Bridge contact
- ③ Rocker and storage position
- ④ Three position indication
- ⑤ Rocker operating position
- ⑥ Unlocking button
- ⑦ Separation position locking device
- ⑧ Upper wiring terminal
- ⑨ Lower wiring terminal

## Model Explanation and Encoding Rules

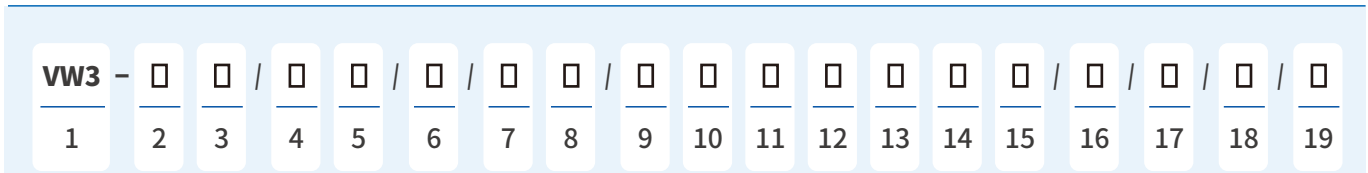

SN	Name	Specification, type code		Description
1	Design code	VW3: Design code		/
2	Frame rating	20: 2000A; 25:2500A; 40: 4000A; 63: 6300A		/
3	Breaking type	S: Standard breaking level; H: High breaking level; HU: High voltage level; HV: Ultra high voltage level		S only for VW3-20
4	Rated current	02: 200A; 04: 400A; 06: 630A; 08: 800A; 10: 1000A; 12: 1250A; 16: 1600A; 20: 2000A; 25: 2500A; 29: 2900A; 32: 3200A; 36: 3600A; 40: 4000A; 50: 5000A; 63: 6300A		/
5	Installation mode	F: Fixed type; D: Drawout type		
6	Number of poles	3: 3P; 4: 4P; 5: 3P+N		3P+N: 3P products are added with N-phase external transformers
7	Controller	VWC2(DIP switch); VWC4 (digital screen); VWC6 (LCD)		VWC2 is only used for VW3-20;
8	Controller optional function	Protection type	Empty: Conventional type; V: Voltage measurement; P: Harmonic measurement and protection	1.VWC4 controller only has S1-4DO; 2. Choose one from the communication functions of "H", "MP", "MD";  3. VWC2 does not have remote reset function; 4. Only VWC6 has communication function;
		Communication function	H: Modbus protocol; MP: Profibus-DP protocol; MD: Devicenet protocol	
		Signal unit	S1: 4DO; S2: 3DO+1DI; S3:2DO+2DI	
		Remote reset function	Z2: AC230V	
		Grounding mode	T: Differential type W: Ground current type Note: 3P+N needs to be added with an external transformer	
		External N-phase transformer	N1; N2; N3; N4	
		Protection form of current leakage: E-type (including the external current leakage transformer)		
		Contact wear equivalent: J		
9	Electric energy storage mechanism	D1: AC400V; D2: AC230V/DC220V; D4: AC/DC110V; D5: DC24V		/
10	Shunt release	F1: AC400V; F2: AC230V/DC220V; F4: AC/DC110V; F5: DC24V		/
11	Closed electromagnet	B1: AC400V; B2: AC230V/DC220V; B4: AC/DC110V; B5: DC24V		/
12	Under-voltage release / Loss of voltage release / Voltage-check release	Under-voltage release	Q1: AC400V; Q2: AC230V; Q5: DC24V	1. Choose one from the Under-voltage release, Loss of voltage release, Voltage-check release;
		Loss of voltage release	S1: AC400V; S2: AC230V	
		Voltage-check release	J1: AC400V; J2: AC230V	
13	Under-voltage release / loss of voltage release Delay time	0: Instantaneous; 1: 1s delay; 3: 3s delay; 5: 5s delay		/
14	Auxiliary contact	A33: 3NO3NC; A44: 4NO4NC; ... ; A1414: 14NO14C		
		A3: Three-group switching; A4: Four-group switching; ...; A14: Fourteen-group switching		

Model Explanation and Encoding Rules

<p>VW3 - □ □ / □ □ / □ □ / □ □ / □ □ / □ □ / □ □ / □ □ / □ □ / □ □ / □ □ / □ □ / □ □ / □ □ / □ □ / □ □ / □ □ / □ □</p>																			
<p>1 2 3 4 5 6 7 8 9 10 11 12 13 14 15 16 17 18 19</p>																			
SN	Name	Specification, type code																Description	
15	Internal Accessories	BX: Closing ready signal output unit																/	
		JS: Counter functional unit																/	
		CM1: Drawout type (with the right side of the door interlock);																/	
		CX: Drawer seat three-position signal output																/	
16	External accessories	M: Doorframe Note: standard																/	
		R: Relay module																/	
		Power supply module								AC65~500V, DC80~700V								Note: standard	/
		S: Button lock																/	
		P2: Voltage conversion module																/	
17	Wiring mode	C1: Horizontal wiring, C2: Vertical wiring, C3: Forward wiring; C4: Mixed wiring (upper horizontal, lower vertical); C5: Mixed wiring (upper vertical, lower horizontal); C6: Mixed wiring (upper forward, lower horizontal); C7: Mixed wiring (upper horizontal, lower forward); C8: Mixed wiring (upper vertical, lower forward); C9: Mixed wiring (upper forward, lower vertical)																/	
		1: Standard wiring, 2: Extended wiring																/	
18	Rated working voltage	KV1: AC400/415V; KV2: AC500/550V; KV3: AC660/690V; KV4: AC800V; KV6: AC1140V; KV7: AC1250V; KV8: AC1500V																/	
19	Language type	Empty: Chinese; Y: English																/	

Interlocking Piece Model Explanation and Encoding Rules

Key lock	SF11: Key lock device (one lock and one key); SF21: Key lock device (two locks and one key); SF31: Key lock device (three locks and one key); SF32: Key lock device (three locks and two keys); SF53: Key lock device (five locks and three keys)	1. Select one from five key locks;
Mechanical interlocking	SR11: Mechanical interlocking device (two sets of steel cables, one for closing and one for opening); SR12: Mechanical interlocking device (three sets of steel cables, one for closing and two for opening); SR21: Mechanical interlocking device (three sets of steel cables, two for closing and one for opening); SY11: Mechanical interlocking device (two sets of hard rods, one for closing and one for opening);	1. Select one from five mechanical interlocks;

Series

VW3-20

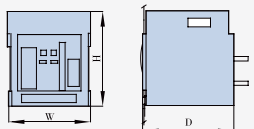

Rated current $I_n$ (A)		200,400,630,800,1000,1250,1600,2000					
Rated working voltage $U_e$ (V) 50Hz/60Hz		AC400/AC415		AC500/AC550		AC660/AC690	
Rated insulation voltage $U_i$ (V)		1150					
Rated impulse withstand voltage $U_{imp}$ (kV)		12					
Power frequency withstand voltage $U(V)$ 1min		AC5000V 50Hz/60Hz					
Number of poles		3P/4P					
N-pole rated current		100% $I_n$					
Breaking capacity code		S	H	S	H	S	H
Rated limit short-circuit breaking capacity (effective value) $I_{cu}$ (kA)		50	66	50	50	25	50
Rated operating short-circuit breaking capacity (effective value) $I_{cs}$ (kA)		50	66	50	50	25	50
Rated short circuit making capacity (peak value) $I_{cm}$ (kA)		105	145	105	105	52.5	105
Rated short-time withstand current (effective value) $I_{cw}$ (kA) 1s		42	55	42	50	25	50
Rated conditional short-circuit current $I_{cc}$ (kA)		42	55	42	50	25	50
Full break time (no additional delay) (ms)		12~18					
Closing time (ms)		≤60					
Operating performance	Electrical life (times)		15000(200~630A) 10000(800~1250A) 10000(1600~2000A)		15000(200~630A) 10000(800~1250A) 10000(1600~2000A)		
	Mechanical life (times)	Without maintenance	15000				
		Maintenance	30000				
Operational condition	Utilization category		B				
	Pollution degree		3				
	Protection grade		IP40				
	Ambient temperature		≥-40°C				
	Altitude		≤5000m				
Outline dimension (mm) (H × W × D) 		Drawout type 3P		357×254×300			
		Drawout type 4P		357×324×300			
		Fixed type 3P		335×266×199			
		Fixed type 4P		335×336×199			

Series

VW3-25

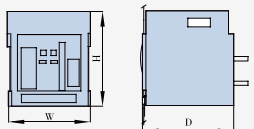

Rated current I <sub>n</sub> (A)		630, 800, 1000, 1250, 1600, 2000, 2500				
Rated working voltage U <sub>e</sub> (V) 50Hz/60Hz		AC400	AC500	AC690	AC800/AC1140	AC1500
Rated insulation voltage U <sub>i</sub> (V)		1800				
Rated impulse withstand voltage U <sub>imp</sub> (kV)		18				
Power frequency withstand voltage U(V) 1min		AC5000V 50Hz/60Hz				
Number of poles		3P/4P		3P	3P	
N-pole rated current		100%I <sub>n</sub>				
Breaking capacity code		H		HU	HV	
Rated limit short-circuit breaking capacity (effective value) I <sub>cu</sub> (kA)		85	75	65	75	50
Rated operating short-circuit breaking capacity (effective value) I <sub>cs</sub> (kA)		85	75	65	75	50
Rated short circuit making capacity (peak value) I <sub>cm</sub> (kA)		187	165	143	165	105
Rated short-time withstand current (effective value) I <sub>cw</sub> (kA) 1s		85	75	65	70	50
Rated conditional short-circuit current I <sub>cc</sub> (kA)		85	75	65	70	50
Full break time (no additional delay) (ms)		12~18				
Closing time (ms)		≤60				
Operating performance	Electrical life (times)		15000 (630~1250A) 11500 (1600~2000A) 11000 (2500A)	12500 (630~1250A) 10000 (1600~2000A) 8000 (2500A)	5000 (630~1250A) 5000 (1600~2000A) 5000 (2500A)	500 (630~1250A) 500 (1600~2000A) 500 (2500A)
	Mechanical life (times)	Without maintenance	15000			
		Maintenance	30000			
Operational condition	Utilization category		B			
	Pollution degree		3			
	Protection grade		IP40			
	Ambient temperature		≥-40°C			
	Altitude		≤5000m			
Outline dimension (mm) (H × W × D) 		Drawout type 3P		430 × 407 × 395		
		Drawout type 4P		430 × 522 × 395		
		Fixed type 3P		390 × 422 × 297.5		
		Fixed type 4P		390 × 537 × 297.5		

## VW3-40



1000, 1250, 1600, 2000, 2500, 2900, 3200, 3600, 4000					
AC400	AC690	AC800	AC1140	AC1250	AC1500
1800					
18					
AC5000V 50Hz/60Hz					
3P/4P		3P		3P	
100%In					
H		HU		HV	
100	85	80	75	66	50
100	85	80	75	66	50
220	187	176	165	145	105
100	85	80	75	66	50
100	85	80	75	66	50
12~18					
≤60					
10000 (1000~2500A) 8000 (2900~3200A) 8000 (3600~4000A)		5000 (1000~2500A) 5000 (2900~3200A) 5000 (3600~4000A)		500 (1000~2500A) 500 (2900~3200A) 500 (3600~4000A)	
10000					
20000					
B					
3					
IP40					
≥-40°C					
≤5000m					
430 × 407 × 395					
430 × 522 × 395					
390 × 422 × 297.5					
390 × 537 × 297.5					

## VW3-63



4000, 5000, 6300			
AC400	AC690	AC800/AC1140	AC1500
1800			
18			
AC5000V 50Hz/60Hz			
3P/4P		3P	3P
50%In			
H		HU	HV
135	120	85	50
135	120	85	50
297	264	187	105
135	120	85	50
135	120	85	50
12~18			
≤60			
6000 (4000A) 4000 (5000A) 2000 (6300A)	3500 (4000A) 2500 (5000A) 1500 (6300A)	2500 (4000A) 1500 (5000A) 1000 (6300A)	500 (4000A) 400 (5000A) 500 (6300A)
6500			
13000			
B			
3			
IP40			
≥-40°C			
≤5000m			
480 × 853 × 395			
480 × 900 × 395			
390 × 800 × 297.5			
390 × 915 × 297.5			

Model	VWC2	VWC4	VWC4(V)	VWC6	VWC6(V)	VWC6(P)
						
Display interface						
DIP switch	✓	—	—	—	—	—
Digital tube numbers and symbols display	—	✓	✓	—	—	—
LCD panel symbols and graphics display	—	—	—	✓	✓	✓
<b>Protection function</b>						
Overload long-time delay protection	✓	✓	✓	✓	✓	✓
Overload thermal memory	✓	✓	✓	✓	✓	✓
Overload pre-alarm/alarm output	—	✓/■	✓/■	✓/■	✓/■	✓/■
Short circuit short-time delay protection	✓	✓	✓	✓	✓	✓
Short-time delay thermal memory	✓	✓	✓	✓	✓	✓
Short circuit instantaneous protection	✓	✓	✓	✓	✓	✓
Ground protection (differential type/W ground current type)	✓	✓	✓	✓	✓	✓
Grounding alarm/alarm output	—	✓/■	✓/■	✓/■	✓/■	✓/■
Current leakage protection/alarm/alarm output	—	—	—	■/■/■	■/■/■	■/■/■
Neutral wire protection	✓	✓	✓	✓	✓	✓
Current unbalance protection/alarm/alarm output	—	✓/—/—	✓/—/—	✓/✓/■	✓/✓/■	✓/✓/■
MCR&HSISC	✓	✓	✓	✓	✓	✓
Load monitoring/alarm/alarm output	—	■/■/■	■/■/■	■/■/■	■/■/■	■/■/■
Undervoltage protection /alarm/alarm output	—	—	—	—	✓/✓/■	✓/✓/■
Overvoltage protection /alarm/alarm output	—	—	—	—	✓/✓/■	✓/✓/■
Voltage unbalance protection/alarm/alarm output	—	—	—	—	✓/✓/■	✓/✓/■
Phase sequence protection/alarm/alarm output	—	—	—	—	✓/✓/■	✓/✓/■
Underfrequency protection/alarm/alarm output	—	—	—	—	✓/✓/■	✓/✓/■
Overfrequency protection/alarm/alarm output	—	—	—	—	✓/✓/■	✓/✓/■
Current required value protection/alarm/alarm output	—	—	—	—	✓/✓/■	✓/✓/■
Reverse power protection/alarm/alarm output	—	—	—	—	—	✓/✓/■

Measuring function						
Current measurement (phase pole, N-pole, grounding)	✓	✓	✓	✓	✓	✓
Voltage (phase voltage, circuit voltage, voltage unbalance rate)	—	—	✓	—	✓	✓
Phase sequence detection	—	—	—	—	✓	✓
Frequency measurement	—	—	✓	—	✓	✓
Required value measurement (current)	—	—	—	—	✓	✓
Required value measurement (power)	—	—	—	—	—	✓
Power measurement (active power, reactive power, apparent power) <sup>①</sup>	—	—	✓	—	—	✓
Power factor measurement	—	—	✓	—	—	✓
Electric energy measurement (active electric energy, reactive electric energy, apparent electric energy)	—	—	—	—	—	✓
Harmonics measurement	—	—	—	—	—	✓
Maintenance function						
LED fault status indication	✓	✓	✓	✓	✓	✓
Fault record (8 times) and query <sup>②</sup>	✓	✓	✓	✓	✓	✓
Displacement record (8 times) <sup>③</sup>	—	—	—	✓	✓	✓
Alarm history query (8 times) <sup>④</sup>	—	—	—	✓	✓	✓
Fault tripping signal output <sup>⑤</sup>	✓	✓	✓	✓	✓	✓
Self-diagnostic function	✓	✓	✓	✓	✓	✓
Simulating tripping test function	✓	✓	✓	✓	✓	✓
Contact wear equivalent (alarm) query	—	■	■	✓	✓	✓
Query of number of operations	—	✓	✓	✓	✓	✓
Clock function	—	✓	✓	✓	✓	✓
Other						
Remote reset of controller	■	■	■	■	■	■
Signal unit	—	■	■	■	■	■
Selective area interlock	—	—	—	■	■	■
Communication	—	—	—	■	■	■
Protection curve	I <sup>2</sup> T(Default), standard inverse time limit		I <sup>2</sup> T (Default), Standard inverse time limit, Fast inverse time limit, Express inverse time limit (G), Express inverse time limit(M), High-voltage fuse compatible			

- Note:**
- ①. VWC4 (V) power measurement only have active power;
  - ②. VMC2 only have fault type,VWC4/VWC4(V) only have the record of last one fault type and data value;
  - ③. Record the displacement include: displacement type (closing, opening, or tripping), displacement reason (local/remote operation, fault/test tripping), displacement time (year, month, day, hour, minute, second);
  - ④. Record the alarm history: Alarm type, alarm domain value, alarm time (year, month, day, hour, minute, second);
  - ⑤. Trip parameters: trip type, trip domain value, delay time, current or voltage value, time (year, month, day, hour, minute, second), MCR trip, undervoltage trip, except for HSISC trip;
  - ⑥. "✓"represents with this function, "—"represents without this function, "■"represents optional function;
  - ⑦. V and P function type are optional;
  - ⑧. If selected the unit function, that will be achieved alarm and switch output functions or area selective interlocking functions.

## VWC2 Controller

### Standard function

- Overload long-time delay protection, Short circuit short-time delay protection, Short circuit instantaneous protection
- Function test
- Fault record
- Overload thermal memory
- Self-diagnostic function
- Current bar display
- Fault status indication & Fault value indication

### Optional function

- Ground Fault Protection
- Current unbalance protection
- Signal unit
- MCR & HCISC

- 1 Reset button
- 2 Rated current
- 3 Current bar indicator light
- 4 Fault indicators

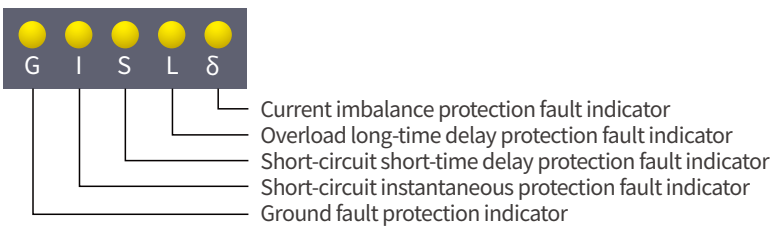

- 5 Overload long-time delay protection setting DIP switch

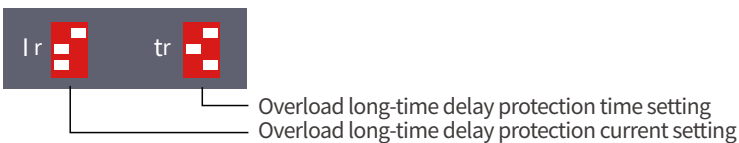

- 6 Short-circuit short-time delay protection setting DIP switch

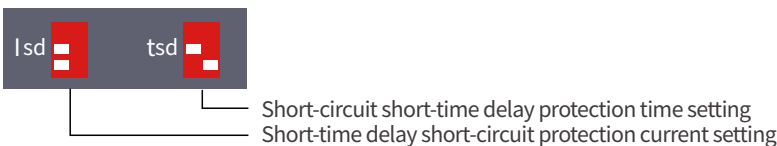

- 7 Short-circuit instantaneous protection current setting DIP switch

- 8 Ground fault protection setting DIP switch



- 9 Operation indicator
- 10 Overload indicator
- 11 Fault check button
- 12 Test trip button
- 13 Clear indicator button
- 14 Test port

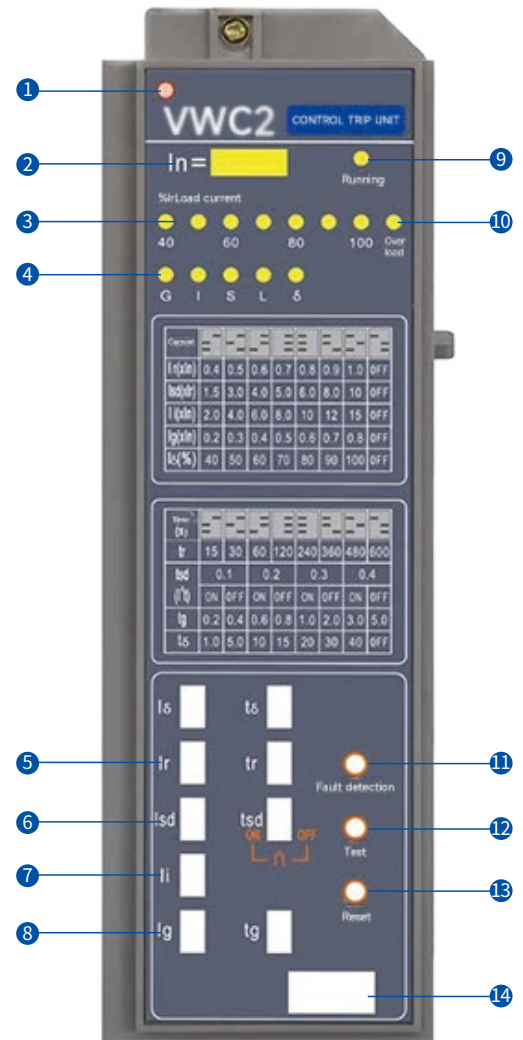

### Note:

1. Move the dial switch by using a special tool (screwdriver for small clocks and watches), so as to make it point to the scale value or position corresponding to protection parameter. When dialing, it should not point to the middle position between two scale values.





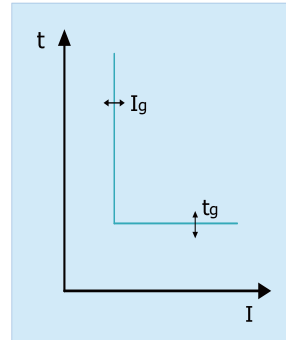
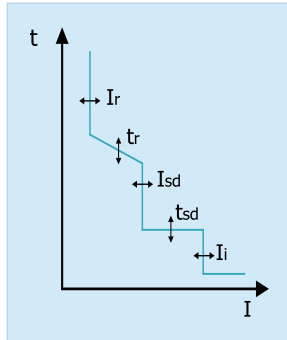



2. The protection parameters shall not be cross-set (with the requirement of  $I_r < I_{sd} < I_i$ ).

## VWC2 Controller protection characteristics











Overload long-time delay										
Current setting value $I_r$ , Current tolerance error $\pm 10\%$		$(0.4, 0.5, 0.6, 0.7, 0.8, 0.9, 1.0) \times I_n + \text{OFF}$								
Tripping time $t_r$ tolerance error $\pm 15\%$	Current	Tripping time								
	$\leq 1.05I_r$	Inaction within 2h								
	$> 1.20I_r$	Action within 1h								
	$1.5I_r$	Setting time $t_r$ (s)	15	30	60	120	240	360	480	600
$2.0I_r$	Tripping time $t_r$ (s)	8.4	16.9	33.8	67.5	135	202.5	270	337.5	
$7.2I_r$	Tripping time $t_r$ (s)	0.65	1.3	2.6	5.2	10	15.6	20	26	
Thermal memory protection	30min+OFF (clear the thermal memory when the power off)									
Short-circuit short time-delay										
Current setting value $I_{sd}$ , Current tolerance error $\pm 10\%$		$(1.5, 3, 4, 5, 6, 8, 10) \times I_r + \text{OFF}$								
Tripping time $t_{sd}$ tolerance error $\pm 15\%$	ON: The short-time delay inverse time limit is on	$I_{sd}$	0.1	0.2	0.3	0.4				
	OFF: The short-time delay inverse time limit is off	$(I^2t)$	ON	OFF	ON	OFF	ON	OFF	ON	OFF
Thermal memory protection	30min+OFF (clear the thermal memory when the power off)									
Short-circuit instantaneous protection										
Current setting value $I_i$ , Current tolerance error $\pm 10\%$		$(2, 4, 6, 8, 10, 12, 15) \times I_n + \text{OFF}$								
Tripping time $t_3$		Within 30ms								
Ground fault protection										
Current setting value $I_g$ , Current tolerance error $\pm 10\%$		$(0.2, 0.3, 0.4, 0.5, 0.6, 0.7, 0.8) \times I_n + \text{OFF}$								
Tripping time $t_g$ tolerance error $\pm 15\%$	Fixed time-limit	Setting time $t_g$ (s)	0.2	0.4	0.6	0.8	1	2	3	5

## VWC2 Controller time setting value reference table

DIP switch setting								
tr	15	30	60	120	240	360	480	600
tsd	0.1		0.2		0.3		0.4	
(I <sup>2</sup> t)	ON	OFF	ON	OFF	ON	OFF	ON	OFF
tg	0.2	0.4	0.6	0.8	1.0	2.0	3.0	5.0
tδ	0.1	5	10	15	20	30	40	OFF

## VWC2 Controller current setting value reference table

DIP switch setting								
I <sub>r</sub> (xI <sub>n</sub> )	0.4	0.5	0.6	0.7	0.8	0.9	1.0	OFF
I <sub>sd</sub> (xI <sub>r</sub> )	1.5	3	4	5	6	8	10	OFF
I <sub>i</sub> (xI <sub>n</sub> )	2	4	6	8	10	12	15	OFF
I <sub>g</sub> (xI <sub>n</sub> )	0.2	0.3	0.4	0.5	0.6	0.7	0.8	OFF
I <sub>δ</sub> (%)	40	50	60	70	80	90	100	OFF

**Note:** OFF indicates protection function is deactivated.

## VWC4 Controller

### Standard function

- Overload long-time delay protection, Short circuit short-time delay protection, Short circuit instantaneous protection
- Ground Fault Protection
- Function test
- Fault record
- Overload thermal memory
- Self-diagnostic function
- Current measurement
- Fault status indication & Fault value indication

### Optional function

- Current unbalance protection
- Signal unit
- MCR & HCISC
- Load monitoring
- Voltage measurement
- Contact wear equivalent indication
- Voltage protection
- Current leakage protection
- Power factor measurement
- frequency measurement
- Power measurement
- Electric energy measurement
- Voltage measurement

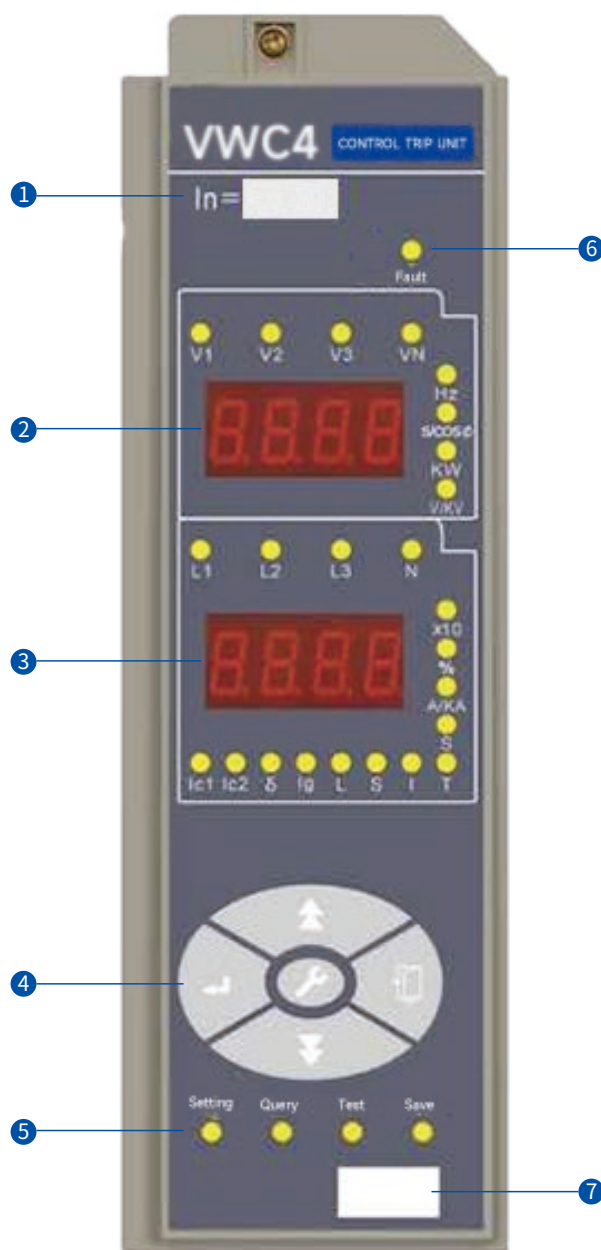

- ① Rated current
- ② Voltage and Power
- ③ Current
- ④ Setting button
- ⑤ Setup, query indicators
- ⑥ Fault and alarm indicators
- ⑦ Test port

**Note:** Protection parameters must not be cross set,  
 $I_r < I_{sd} < I_{io}$

### Panel Display Description

- “HZ” Lighting on, is frequency
- “S/COS $\Phi$ ” Lighting on, is time; flashing is power factor
- “kW” Lighting on, is active power; flashing is active electric energy
- “%” Lighting on, is contact wear equivalent indication
- “ $\times 10$ ” Lighting on, is number of opening and closing operations
- “ $\delta$ ” “%” and “L1/L2/L3” Lighting on, is the imbalance ratio
- “Ig” and “A/kA” Lighting on, is grounding current
- “L1/L2/L3” and “A/kA” Lighting on, is current
- “N” and “A/kA” Lighting on, is N-phase current
- “A/kA” Flashing is kA, lighting on is A
- One of “V1”, “V2”, “V3” and V lighting on, is three phase line voltage
- One of “V1”, “V2”, “V3” and “N” and “V” lighting on, is corresponding phase voltage
- When the “T” lighting on, have the self-diagnostic fault, press Enter show the fault code
- If the fault is resolved, press the return button to clear self-diagnostic fault, “T” no lighting
- If there are multiple diagnostic faults, press the ▲ and ▼ keys to view the fault codes
- Fault code:

ER01	ER02	ER03	ER12	ER13
E <sup>2</sup> PROM error	A/D error	overtemperature	Circuit breaker refused to operate	contact maintained indication

### Controller running status:

- ① **Setting status:** Set lighting on, view or modify the protection setting value
- ② **Query status:** Query lighting on, view the fault history
- ③ **Test status:** Test lighting on, can do the tripping test
- ④ **Fault status:** Fault lighting on, indication the fault type and cycle display of fault current and time
- ⑤ **Communication status:** Communication lighting on, the controller is communicating
- ⑥ **Storage status:** Storage lighting on, change data once
- ⑦ **Self-diagnostic status:** “T” lighting on, have the self-diagnostic fault

VWC4 Controller protection characteristics

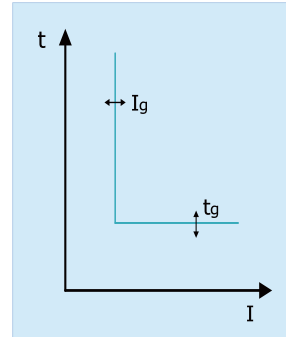
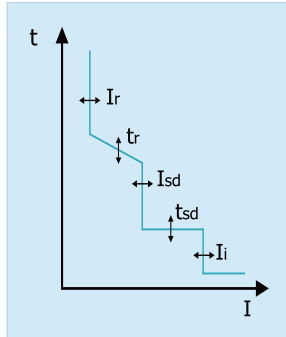

Overload long-time delay protection

Current setting value  $I_r$ , Current tolerance error  $\pm 10\%$  (0.4~1.0)  $\times I_n$ +OFF (step 1A)

Tripping time $t_r$ tolerance error $\pm 15\%$	Current	Tripping time							
	$\leq 1.05I_r$	Inaction within 2h							
	$> 1.20I_r$	Action within 1h							
	Protection curve (default is $I^2T$ )	Tripping time $t_r$ (factor K in bracket)							
	Standard inverse time limit $t=K/(N^{0.02}-1)$	0.61(0.005)	0.98(1.0)	1.47(0.012)	2.46(0.02)	3.68(0.03)	4.91(0.04)	6.14(0.05)	8.29(0.075)
	Fast inverse time limit $t=K/(N-1)$	2(1)	3.2(1.6)	4.8(2.4)	8(4)	12(6)	16(8)	20(10)	27(13.5)
	Express inverse time limit $t=K/(N^2-1)$	8(10)	12.8(16)	19.2(24)	32(40)	48(60)	64(80)	80(100)	108(135)
	Express inverse time limit $t=(K/1.15) \times \log_e [N^2 / (N^2-1.15)]$	112(180)	174(280)	249(400)	373(600)	498(800)	622(1000)	747(1200)	871(1300)
	High-voltage fuse compatible $t=K/(N^4-1)$	2.46(10)	3.94(16)	5.9(24)	9.85(40)	14.8(60)	19.7(80)	24.6(100)	33.2(135)
	$I^2T$ Table $t=(1.5/N)^2 \times K$	15(15)	30(30)	60(60)	120(120)	240(240)	360(360)	480(480)	600(600)

**Note:**  $N=I/I_r$  ( $I$  is the actual fault current,  $I_r$  is the set value of overload current).  
The above set time value is action delay time when  $I=1.5I_r$ , with the of current  $I$  increase, the delay time will be decreases which can be calculated according to the curve formula.

Thermal memory protection 30min+OFF (clear the thermal memory when the power off)

Short-circuit short time-delay protection

Current setting value  $I_{sd}$ , Current tolerance error  $\pm 10\%$  (1.5~15)  $\times I_r$ +OFF (step 1A)

Tripping time $t_{sd}$ tolerance error $\pm 15\%$	Fixed time-limit current setting value	0.1~1s (step 0.1s)
	Inverse time-limit current setting value	The curve is the same as the overload long delay curve, and the curve speed is 10 times faster than the overload long delay (dividing the time calculated by the overload delay curve formula by 10 is the inverse delay time of the short delay)

Thermal memory protection 15min+OFF (clear the thermal memory when the power off)

**Note:** When both the inverse time limit and fixed time limit protection are enabled, the inverse time limit current setting value must be less than the fixed time limit current setting value, otherwise the inverse time limit function will automatically fail. In addition, the actual delay time is not less than the set time of the fixed time limit

Short-circuit instantaneous protection		
Current setting value $I_i$ , Current tolerance error $\pm 10\%$		$(1\sim 20) \times I_n + \text{OFF}$
Action features		$\leq 0.85 I_i$ , inaction
		$> 1.15 I_i$ , action
Ground protection		
Current setting value $I_r$ , Current tolerance error $\pm 10\%$		$(0.2\sim 1.0) \times I_n + \text{OFF}$ (min100A)
Action features		$\leq 0.8 I_g$ , inaction
		$\geq 1.0 I_g$ , delay action
Tripping time $t_g$ tolerance error $\pm 10\%$	Fixed time-limit	0.1~100s+OFF (0.1~1s, step0.1s, 1s~100s, step1s, OFF: alarm does not trip)
	Inverse time shear coefficient $C_r$	1.5~6+OFF (step 0.5, OFF: inverse time-limit OFF)
	Inverse time-limit formula	Formula $t = t_g \times C_r \times I_g / I$ t - Delay time; $T_g$ - Set delay time; $C_r$ - Shear coefficient; $I_g$ - Set action current; I - Ground current; When the multiple of fault current ( $I/I_g$ ) is less than $C_r$ , the action characteristic is inverse time characteristic; When the fault current multiple is greater than or equal to $C_r$ , the action characteristic is a fixed time limit
Neutral line protection		
Current setting value $I_n$ , Current tolerance error $\pm 10\%$		$(0.5, 1.0) \times I_n + \text{OFF}$
Action time		same as long time-delay time
Current unbalance protection		
Protection setting value		40%~100%+OFF
Action or alarm features		$\leq 0.9 \delta$ , inaction
		$> 1.1 \delta$ , action delay or alarm
Delay time (s)		0.1~100s+OFF (OFF: Alarm only, inaction, step0.1s)
Load monitoring function		
Mode 1	Current setting $I_{c1}$ , $I_{c2}$ Adjustment(A)	$(0.2\sim 1.0) \times I_n + \text{OFF}$ (min100A)
	Inverse time-limit $t_{c1}$ , $t_{c2}$ (s)	Same overload long delay curve
Mode 2	Current setting $I_{c1}$ , $I_{c2}$ Adjustment(A)	$(0.2\sim 1.0) \times I_n + \text{OFF}$ (min100A)
	Inverse time-limit $t_{c1}$	Same overload long delay curve
	Fixed time-limit $t_{c2}$	60s

## VWC6 Controller

### Standard function

- Overload long-time delay protection, Short circuit short-time delay protection, Short circuit instantaneous protection
- Ground Fault Protection
- Function test
- Fault record
- Overload thermal memory
- Self-diagnostic function
- Current measurement
- Fault status indication & Fault value indication
- Contact wear equivalent indication
- Record of operations

### Optional function

- Current unbalance protection
- Signal input
- Signal unit
- MCR & HCISC
- Load monitoring
- Power measurement
- Voltage measurement
- Voltage protection
- Current leakage protection
- Required value protection
- Power factor measurement
- Electric energy measurement
- Selective area interlock
- Harmonics measurement
- Frequency measurement
- Reverse power measurement
- Electric energy measurement
- Communication

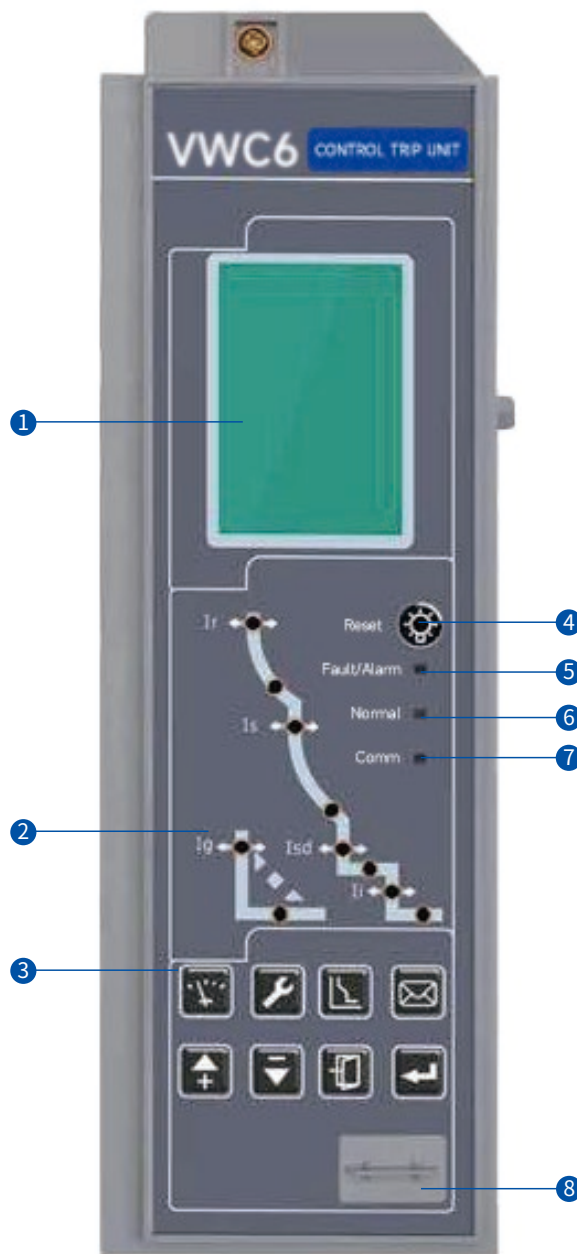

**Note:** Protection parameters must not be cross set,  
 $I_r < I_{sd} < I_{i0}$

- ① LCD interface display
- ② Protection curve
- ③ Function buttons
- ④ Fault and alarm reset button
- ⑤ Fault alarm indicators
- ⑥ Normal indicators
- ⑦ Communication indicators
- ⑧ Test port

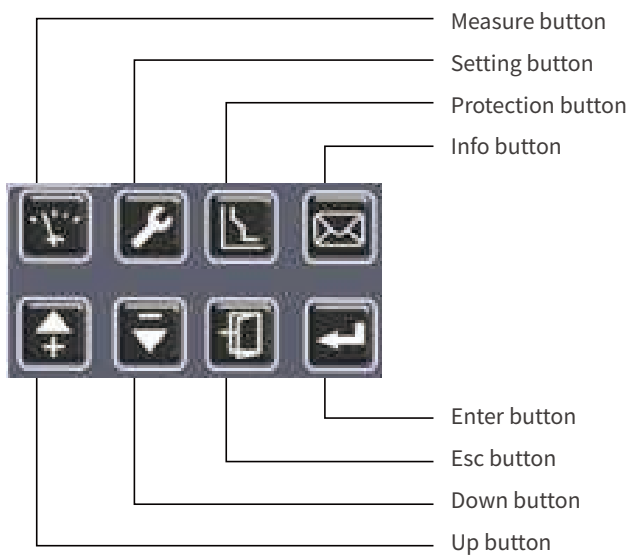

## VWC6 Controller protection characteristics

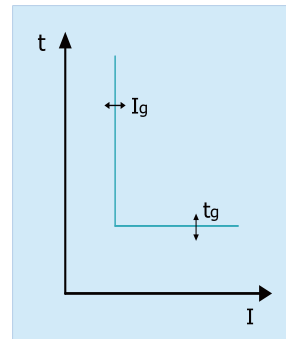
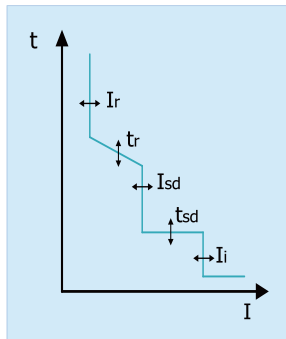

### Overload long-time delay protection

Current setting value  $I_r$ , Current tolerance error  $\pm 10\%$  (0.4~1.0)  $\times I_n + \text{OFF}$  (step 1A)

Current	Tripping time							
	$\leq 1.05I_r$	Inaction within 2h						
$> 1.20I_r$	Action within 1h							
Protection curve (default is $I^2T$ )	Tripping time $t_r$ (factor K in bracket)							
Standard inverse time limit $t = K / (N^{0.02} - 1)$	0.61(0.005)	0.98(1.0)	1.47(0.012)	2.46(0.02)	3.68(0.03)	4.91(0.04)	6.14(0.05)	8.29(0.075)
	11.1(0.09)	17.2(0.14)	24.6(0.2)	36.8(0.3)	49.1(0.4)	61.4(0.5)	73.7(0.6)	86(0.6)
Fast inverse time limit $t = K / (N - 1)$	2(1)	3.2(1.6)	4.8(2.4)	8(4)	12(6)	16(8)	20(10)	27(13.5)
	36(18)	56(28)	80(40)	120(60)	160(80)	200(100)	240(120)	280(140)
Express inverse time limit $t = K / (N^2 - 1)$	8(10)	12.8(16)	19.2(24)	32(40)	48(60)	64(80)	80(100)	108(135)
	144(180)	224(280)	320(400)	480(600)	640(800)	800(1000)	960(1200)	1120(1300)
Express inverse time limit $t = (K / 1.15) \times \log_e [N^2 / (N^2 - 1.15)]$	6.22(10)	9.96(16)	14.9(24)	24.9(40)	37.3(60)	49.8(80)	62.2(100)	84(135)
	112(180)	174(280)	249(400)	373(600)	498(800)	622(1000)	747(1200)	871(1300)
High-voltage fuse compatible $t = K / (N^4 - 1)$	2.46(10)	3.94(16)	5.9(24)	9.85(40)	14.8(60)	19.7(80)	24.6(100)	33.2(135)
	44.3(180)	68.9(280)	98.5(400)	147(600)	197(800)	246(1000)	295(1200)	344(1300)
$I^2T$ Table $t = (1.5/N)^2 \times K$	15(15)	30(30)	60(60)	120(120)	240(240)	360(360)	480(480)	600(600)
	720(720)	840(840)	960(960)	/	/	/	/	/

**Note:**  $N = I / I_r$  ( $I$  is the actual fault current,  $I_r$  is the set value of overload current).  
The above set time value is action delay time when  $I = 1.5I_r$ , with the of current  $I$  increase, the delay time will be decreases which can be calculated according to the curve formula.

Thermal memory protection 30min+OFF (clear the thermal memory when the power off)

### Short-circuit short time-delay protection

Current setting value  $I_{sd}$ , Current tolerance error  $\pm 10\%$  (1.5~15)  $\times I_r + \text{OFF}$  (step 1A)

Tripping time $t_{sd}$ tolerance error $\pm 15\%$	Fixed time-limit current setting value	0.1~0.4s (step 0.1s)
	Inverse time-limit current setting value	The curve is the same as the overload long delay curve, and the curve speed is 10 times faster than the overload long delay (dividing the time calculated by the overload delay curve formula by 10 is the inverse delay time of the short delay)

Thermal memory protection 15min+OFF (clear the thermal memory when the power off)

**Note:** When both the inverse time limit and fixed time limit protection are enabled, the inverse time limit current setting value must be less than the fixed time limit current setting value, otherwise the inverse time limit function will automatically fail. In addition, the actual delay time is not less than the set time of the fixed time limit

Short-circuit instantaneous protection		
Current setting value $I_i$ , Current tolerance error $\pm 10\%$	$(1\sim 20) \times I_n + \text{OFF}$ (min100A)	
Action features	$\leq 0.85 I_i$ , inaction	
	$> 1.15 I_i$ , action	
Ground protection		
Current setting value $I_r$ , Current tolerance error $\pm 10\%$	$(0.2\sim 1.0) \times I_n + \text{OFF}$ (min100A)	
Action features	$\leq 0.8 I_g$ , inaction	
	$\geq 1.0 I_g$ , delay action	
Tripping time $t_g$ tolerance error $\pm 10\%$	Fixed time-limit	$0.1\sim 100\text{s} + \text{OFF}$ (0.1~1s, step 0.1s, 1s~100s, step 1s, OFF: alarm does not trip)
	Inverse time shear coefficient $C_r$	$1.5\sim 6 + \text{OFF}$ (step 0.5, OFF: inverse time-limit OFF)
	Inverse time-limit formula	Formula $t = t_g \times C_r \times I_g / I$ t - Delay time; $T_g$ - Set delay time; $C_r$ - Shear coefficient; $I_g$ - Set action current; I - Ground current; When the multiple of fault current ( $I/I_g$ ) is less than $C_r$ , the action characteristic is inverse time characteristic; When the fault current multiple is greater than or equal to $C_r$ , the action characteristic is a fixed time limit
Execution mode: tripping + close		
Ground protection (The ground alarm and ground protection functions are independent of each other and have their own independent parameter settings, which can exist simultaneously)		
Alarm action setting value	current	$(0.2\sim 1.0) \times I_n$ (min100A)
	time	$0.1\sim 100\text{s} + \text{OFF}$
Alarm cleared setting	current	$(0.2\sim 1.0) \times I_n$ (min100A)
	time	$0.1\sim 100\text{s} + \text{OFF}$
Neutral line protection		
Current setting value $I_n$ , Current tolerance error $\pm 10\%$	$(0.5, 1.0, 1.6, 2.0) \times I_n + \text{OFF}$	
Action time	same as long time-delay time	
Current unbalance protection		
Protection setting value	5% ~ 60% (step 1%)	
Delay time	0.1 s ~ 40s (step 0.1s)	
Protection return setting value	5% ~ start value (step 1%)	
Delay time	start value (step 1%)	
Action or alarm features	$\leq 0.9 \delta$ , inaction	
	$> 1.1 \delta$ , action delay or alarm	
Execution mode: Tripping+alarm+close		
Load monitoring function		
Mode 1	Current setting $I_{c1}, I_{c2}$	$(0.2\sim 1) \times I_r$ (min100A, step 1A)
	Inverse time-limit $t_{c1}, t_{c2}$	$(20\%\sim 80\%) \times t_r$
Mode 2	Current setting $I_{c1}$ (unloading)	$(0.2\sim 1) \times I_r$ (min100A)
	Current setting $I_{c2}$ (return)	$0.2 \times I_r \sim I_{c1}$
	Inverse time-limit $t_{c1}$	$(20\%\sim 80\%) \times t_r$
	Fixed time-limit $t_{c2}$	10s~600s

## VWC4 Controller

Voltage unbalance protection				
Protection start setting value	2%~30% (accuracy 1%)			
Protection action delay time setting (s)	0.2~60 (accuracy 0.1)			
Protection action return setting value	2%~start value (accuracy 1%)	This set value only exists when the "alarm" execution method , and the return value must be less than or equal to the start value.		
Protection return delay time (s)	0.2~60 (accuracy 0.1)			
Action features of voltage unbalance protection/alarm (Accuracy of ±10%)	Actual voltage unbalance rate/setting value ≥1.1	Action or alarm according to the set delay time		
	Actual voltage unbalance rate/setting value <0.9	Inaction (no alarm)		
Voltage unbalance alarm return action features(Accuracy of ±10%)	Actual voltage unbalance rate/setting value ≤0.9	Returns according to the set delay time		
	Actual voltage unbalance rate/setting value >1.1	Non-return		
Voltage unbalance protection alarm DO output	Added the "Voltage Unbalance Alarm" contact output when the alarm execution mode			
Undervoltage protection				
Action setting value(V)	100~return setting value(step 1)			
Protection action delay time setting value(s)	0.2~60(step 0.1)			
Action return setting value (V)	action setting value~1200(step 1)	This set value only exists when the "alarm" execution method , and the return value must be less than or equal to the start value.		
Protection action delay time setting value(s)	0.2~60(step 0.1)			
Action features of voltage unbalance protection/alarm (Accuracy of ±10%)	U <sub>max</sub> / action setting value<0.9	Action or alarm according to the set delay time		
	U <sub>max</sub> / action setting value≥1.1	Inaction (no alarm)		
Undervoltage alarm return action features (Accuracy of ±10%)	U <sub>min</sub> / action setting value>1.1	Returns according to the set delay time		
	U <sub>max</sub> / action setting value≤0.9	Non-return		
Undervoltage protection alarm DO output	Added the "Undervoltage Alarm" contact output when the alarm execution mode			
Overvoltage protection				
Action setting value(V)	return setting value~1200 (step 1)			
Protection action delay time setting value(s)	0.2~60 (step 0.1)			
Action return setting value (V)	100~action setting value (step 1)	This set value only exists when the "alarm" execution method , and the return value must be less than or equal to the start value.		
Return action delay time setting value(s)	0.2~60 (step 0.1)			
Action features of overvoltage protection/alarm (Accuracy of ±10%)	U <sub>min</sub> / action setting value≥1.1	Action or alarm according to the set delay time		
	U <sub>min</sub> / action setting value<0.9	Inaction (no alarm)		
Overvoltage protection alarm return features (Accuracy of ±10%)	U <sub>max</sub> / action setting value≤0.9	Returns according to the set delay time		
	U <sub>max</sub> / action setting value>1.1	Non-return		
Overvoltage protection alarm DO output	Added the "Overvoltage Alarm" contact output when the alarm execution mode			
Required current value protection				
Protection start setting value	(0.2~1.0) × I <sub>n</sub> (step 2)			
Protection action delay time setting value(s)	15~1500 (step 1)			
action return setting value	0.2I <sub>n</sub> ~start value (step 2)	This set value only exists when the "alarm" execution method , and the return value must be less than or equal to the start value.		
Return action delay time setting value(s)	15~3000 (step 1)			
Action features of required current value protection protection/alarm (Accuracy of ±10%)	I /setting value≥1.1	Action or alarm according to the set delay time		
	I /setting value<0.9	Inaction (no alarm)		
Voltage unbalance alarm return action features(Accuracy of ±10%)	I /setting value≤0.9	Returns according to the set delay time		
	I /setting value>1.1	Non-return		
Required current value protection alarm DO output	Added the "Required current value protection" contact output when the alarm execution mode			
Phase sequence protection				
Setting range of action phase sequence	△φ: A, B, C / △φ: A, C, B			
Phase sequence protection alarm DO output	Added the "Phase sequence protection" contact output when the alarm execution mode			
Execution mode	Alarm/tripping/close			
Underfrequency, overfrequency protection				
Start setting value	Action start setting value	underfrequency	45~return value (step 0.5Hz)	This setting value only exists when the "alarm" execution mode
		overfrequency	return value~65 (step 0.5Hz)	
	Action delay time setting value (s)	0.1~5s+OFF (0.1~1s step 0.1, 1~5s step 1s)		
	Alarm action return setting value (Hz)	underfrequency	start value~65Hz (step 0.5Hz)	
overfrequency		45Hz~Start value (step 0.5Hz)		
Alarm return delay time (s)	0.2~36.0s (step 0.1s)			
	Added the "Underfrequency, overfrequency protection alarm" contact output when the alarm execution mode			
Underfrequency, overfrequency protection alarm DO output	Added the "Underfrequency, overfrequency protection alarm" contact output when the alarm execution mode			
Execution mode	Phase sequence protection alarm Alarm/tripping/closeDO output			

## Controller protection function description

### Ground fault protection features

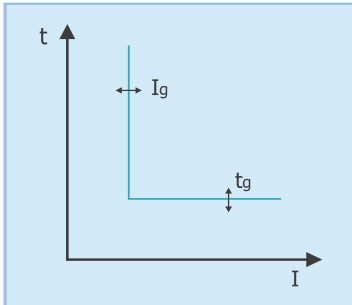

### Ground fault protection

- Current setting value  $I_g$  adjustable, when fixed or inverse time limit ground fault protection
- Delay time  $t_g$  adjustable
- Turning off (OFF), only alarm, no tripping
- Ground protection type
- Type 1
- Type 2
- Type 3
- Type 4

#### Type 1

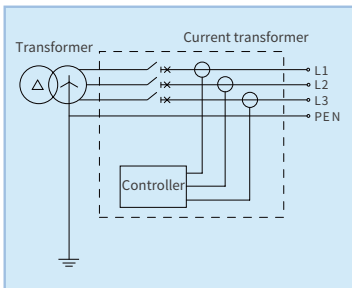

**Type1: The TN-C and TN-C-S distribution systems use three-pole circuit breakers without neutral current transformers.**

- The ground fault protection signal from the vector sum of the three-phase current.
- The protection feature is fixed limit time or inverse limit time protection
- Only applicable when the three-phase unbalanced current and harmonic current flowing through the PEN neutral protection line are very small

#### Type 2

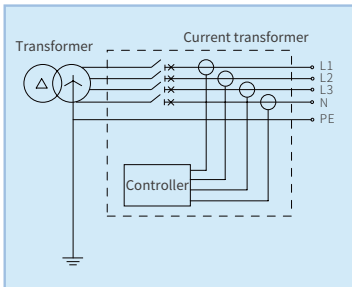

**Type 2: The TN-S distribution system use four pole circuit breaker with internal neutral current transformer.**

- The ground fault protection signal from the vectors sum of the three-phase current and N-phase current .
- The protection feature is fixed limit time or inverse limit time protection

#### Type 3

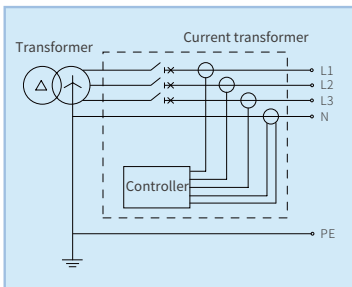

**Type 3: The TN-S distribution system use three-pole circuit breaker and external neutral current transformer.**

- The ground fault protection signal from the vectors sum of the three-phase current and N-phase current .
- The protection feature is fixed limit time or inverse limit time protection

**Note:** The transformer wire length shall not exceed 2m

#### Type 4

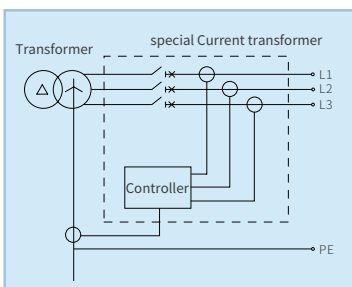

**Type 4: The T-T distribution system use three-pole circuit breaker and external ground current transformer.**

- The ground fault protection signal from the current on the grounding wire at the center point of the low-voltage terminal of the transformer
- The protection feature is fixed limit time or inverse limit time protection

**Note:** The transformer wire length shall not exceed 2m

## Signal unit

### DI: input

1-2 programmable optoelectronic coupling switch input (DI)

Function setting	General,alarm, tripping, regional interlocking, grounding interlocking, short circuit interlocking	
DI Input form	Normally open	Normally closed

### DO: output

2-4 Switch Output (DO)

Function setting	See the table below, "Parameter Settings of Switch Output (DO)"			
Execution mode	Normally opened level	Normally closed level	Normally opened Impulse	Normally closed Impulse
Impulse time	N/A		1~360s (step 1s)	

### Parameter Settings of Switch Output (DO)

General	Alarm	Fault tripping	Self-diagnostic function alarm	Instantaneous fault
Grounding/current leakage fault	Overload pre-alarm	Overload fault	Short-time delay fault	Undervoltage fault
Overvoltage fault	Grounding/leakaging alarm	Current unbalance fault	Neutral line fault	Required value fault
Reverse power fault	Voltage unbalance fault	Underfrequency fault	Overfrequency fault	Phase sequence fault
MCR/HSISC fault	Short circuit interlocking	Remote On	Remote Off	Required value out-of-limit
A-phase required value fault	B-phase required value fault	C-phase required value fault	N-phase required value fault	/

**Note:** The general table function can be setting on the computer in the communication group,when the DI/DO not be setting in the controller

## Communication

Communication type controller connects to the communication products ,achieve the remote communication, remote regulating, remote control and remote sensing functions,for monitor the circuit breaker working on time.As "Communication Networking Diagram" showing, achieved the local monitoring and ultra remote monitoring to monitor the operating status of circuit breakers and control them on time

The specific configuration and communication interface parameters as the below table show:

Applicable controller	VWC4 , VWC6 (Communication)	
Communication mode	RS485(Photoelectric isolation)	
Communication cable	Shielded twisted pair cable	
Communication distance	1200m <sup>(1)</sup>	
Communication protocol	Standard	Modbus-RTU
	Optional	Profibus-DP or DeviceNet Accessories required: Profibus-DP conversion module or DeviceNet conversion module
Communication instructions	《PTU series intelligent controller Modbus communication protocol V3.0》	
Transmission rate (bit/s)	9.6K , 19.2K , 38.4K (Settable)	
Communication address	0~255 (Settable)	
The 'remote control' function requires additional accessories <sup>(2)</sup>	1) 201 Relay module; 2) power supply module	
When connecting the monitoring system (RS232 interface) with the system, accessories <sup>(3)</sup> are required	RS485/RS232 conversion module	
When connecting the monitoring system (Ethernet interface) with the system, accessories are required	(ModBUS / TCP / IP) Ethernet conversion module	

**Note:** (1).When the bus length exceeds 1200 meters, additional a "communication relay module";  
 (2).Achieve the remote communication, remote regulating, remote control and remote sensing functions without additional accessories  
 (3).When monitor system have the RS485 interface,no need "RS485/RS232 conversion module"

## Controller factory setting



Overload long-time delay protection	I <sub>r</sub>	I <sub>n</sub>
	t <sub>r</sub>	60s
Short circuit short-time delay protection	I <sub>sd</sub>	3I <sub>r</sub>
	t <sub>sd</sub>	0.1s
Short circuit instantaneous protection	I <sub>i</sub>	6I <sub>n</sub>
Ground Fault Protection	I <sub>g</sub>	OFF
Current unbalance protection	OFF	
Neutral line protection	100%I <sub>r</sub>	
Current unbalance protection	OFF	
Undervoltage protection	OFF	
Overvoltage protection	OFF	
Required current value protection	OFF	
Phase sequence protection	OFF	
Underfrequency, overfrequency protection	OFF	
MCR	VW3-20(S/H)	20kA
	VW3-25(H/HU/HV)	30kA
	VW3-40(H/HU/HV)	45kA
	VW3-63(H/HU/HV)	75kA
HSISC	VW3-20(S/H)	OFF
	VW3-25(H/HU/HV)	OFF
	VW3-40(H/HU/HV)	OFF
	VW3-63(H/HU/HV)	OFF

Contact factory setting				
	Contact 1	Contact 2	Contact 3	Contact 4
VWC2/VWC4/VWC6	Overload fault output	Fault tripping output	Self-diagnostic function alarm	Fault tripping
VWC6 (Communication)			Remote Off	

## Main network communication

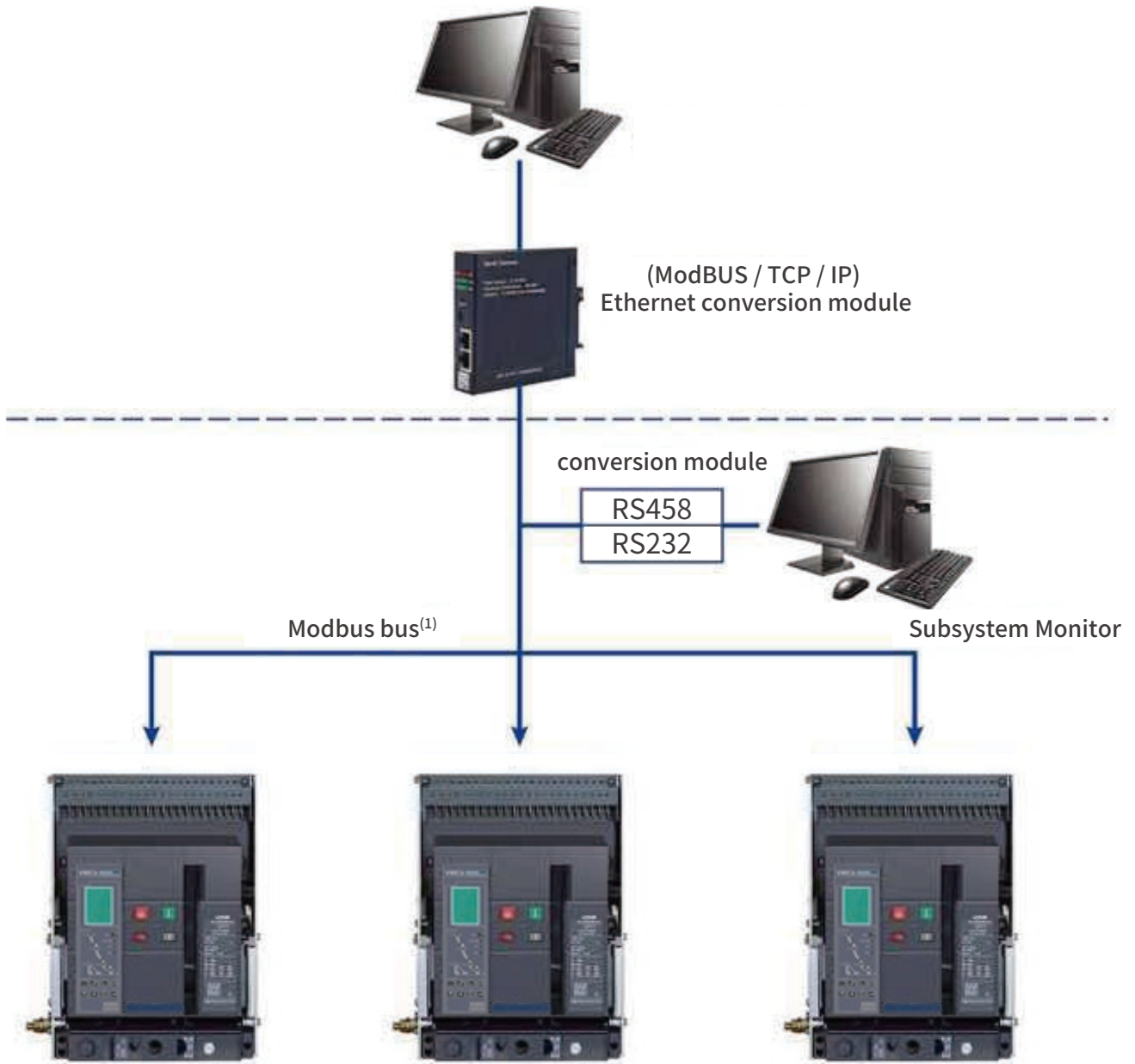

**Note:** (1) When the bus with Profibus-DP or DeviceNet, need to be converted by Profibus-DP or DeviceNet conversion module

## Controller

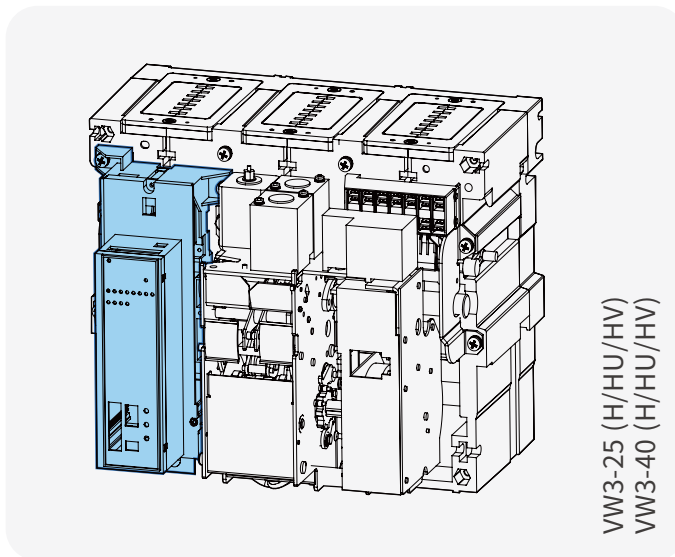

VW3-25 (H/HU/HV)  
VW3-40 (H/HU/HV)

Controller	Controller mode	Supply voltage Ue (V)
	VWC2	AC65~500V, DC80~700V
	VWC4	
	VWC6	
	VWC6 (Communication)	

## Motor operating mechanism (D)

The circuit breaker has motor energy storage and automatic energy re-storage function (also energy storage by manual)

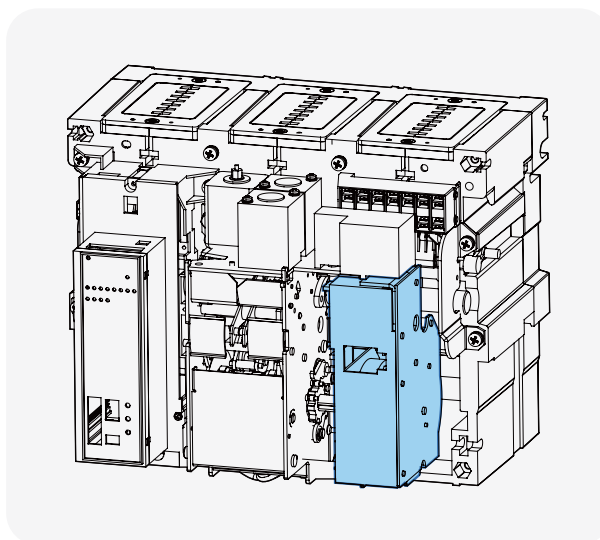
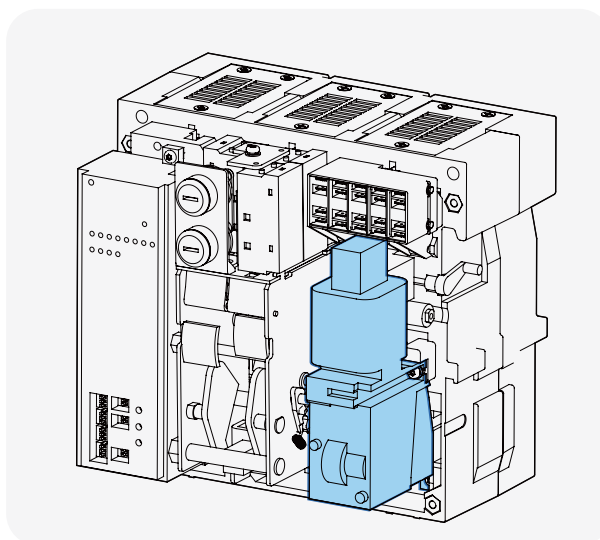

Rated control supply voltage $U_s$ (V)		AC230	AC400	DC110	DC220
Operation voltage		(0.85~1.1) $U_s$			
Power consumption	VW3-20 (S/H)	100VA		100W	
	VW3-25 (H/HU/HV)	150VA		150W	
	VW3-40 (H/HU/HV)	150VA		150W	
	VW3-63 (H/HU/HV)	190VA		190W	
Energy storage time(s)		5s			

## Closed electromagnet (B)

After the energy storage is completed, closed electromagnet release the operating mechanism energy, make the circuit breaker quickly closed.

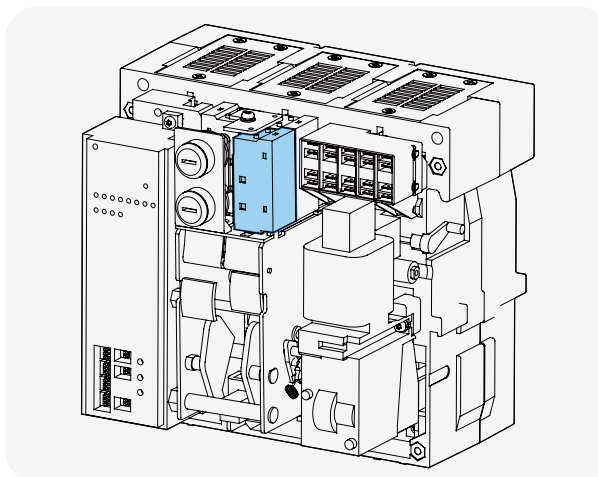

Power Consumption Table of Closed Electromagnet

Rated insulation voltage(Ui)	Rated control supply voltage(Us)	Closed current		Instantaneous power	
		VW3-20 (S/H)	VW3-25 (H/HU/HV) VW3-40 (H/HU/HV) VW3-63 (H/HU/HV)	VW3-20 (S/H)	VW3-25 (H/HU/HV) VW3-40 (H/HU/HV) VW3-63 (H/HU/HV)
400V	AC380V/AC400V	1A	2.1A	360VA	780VA
	AC220V/AC230V	1.3A	2.8A	295VA	575VA
	DC220V	1.4A	2.9A	280W	630W
	DC110V	2.1A	5.2A	250W	550W

## Shunt release (F)

Can disconnect the circuit breaker by remote operation.

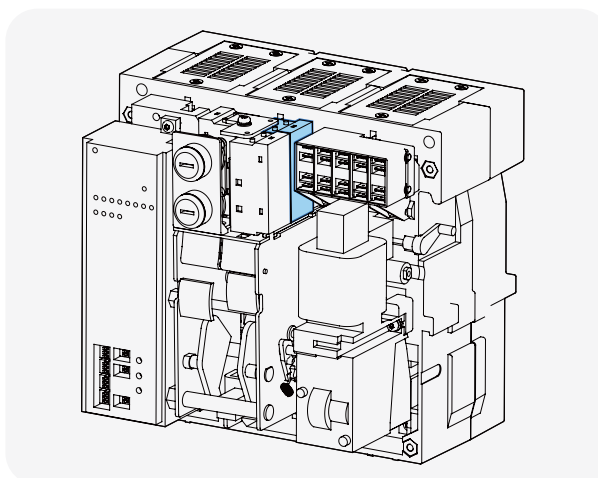

Power Consumption Table of Shunt Release

Rated insulation voltage(Ui)	Rated control supply voltage(Us)	Closed current		Instantaneous power	
		VW3-20 (S/H)	VW3-25 (H/HU/HV) VW3-40 (H/HU/HV) VW3-63 (H/HU/HV)	VW3-20 (S/H)	VW3-25 (H/HU/HV) VW3-40 (H/HU/HV) VW3-63 (H/HU/HV)
400V	AC380V/AC400V	1A	2.1A	360VA	780VA
	AC220V/AC230V	1.3A	2.8A	295VA	575VA
	DC220V	1.4A	2.9A	280W	630W
	DC110V	2.1A	5.2A	250W	550W

## Auxiliary contact

### Internal auxiliary contact

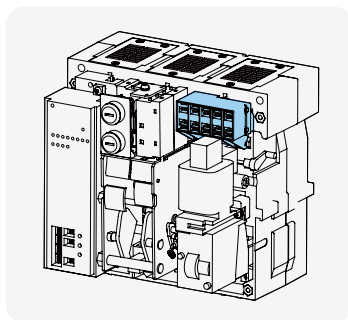
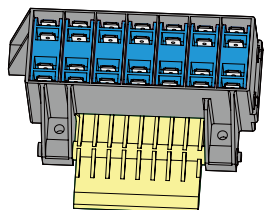

### External auxiliary contact

Min 60mm safety distance of circuit breaker after installation

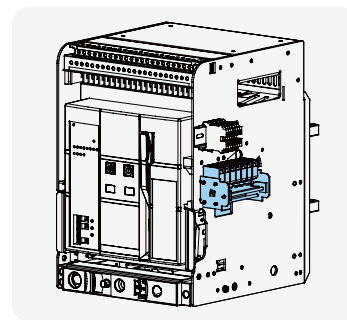
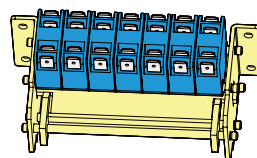

### External auxiliary contact terminal number

Without common point

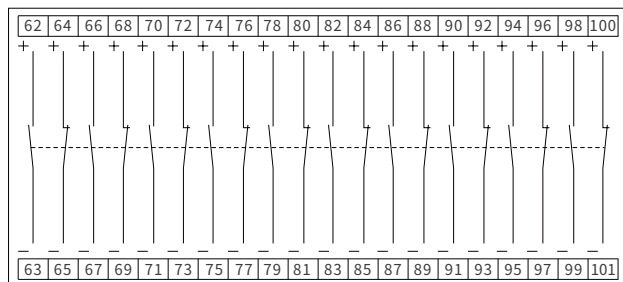

With common point

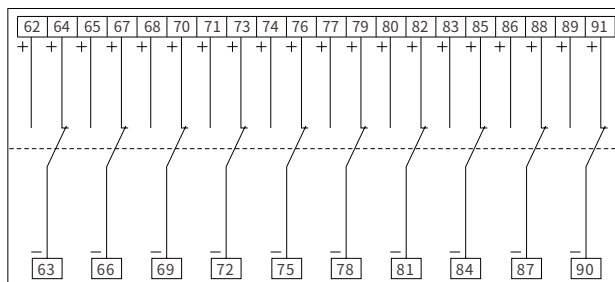

H/HU/HV/Standard have Max 4NO+4NC internal auxiliary contact,if more auxiliary contact ,need the external auxiliary contact

Auxiliary contact	Rated operational voltage Ue(V)		Rated breaking capacity		Agreed thermal current I <sub>th</sub> (A)	
	AC400		800VA		16	
	AC230					
	DC220		300W			
DC110						
Type	Code		Type	Code		
3NO3NC	A33		4NO4NC	A44		
5NO5NC	A55		6NO6NC	A66		
7NO7NC	A77		8NO8NC	A88		
9NO9NC	A99		10NO10NC	A1010		
11NO11NC	A1111		12NO12NC	A1212		
13NO13NC	A1313		14NO14NC	A1414		

**Note:** 1.H/HU/HV series have 3NO 3NC~14NO 14NC  
 NO:normally open contact  
 NC:normally closed contact

## Undervoltage (loss-of-voltage) release (Q)

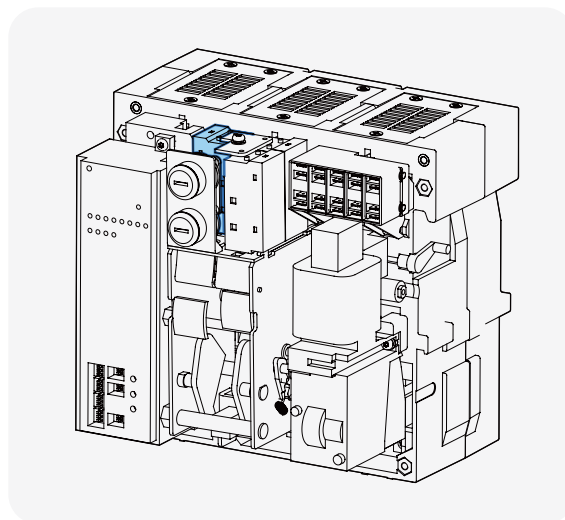

Rated operational voltage (V)		Undervoltage release		Loss-of-voltage release	
		AC230	AC400	AC230	AC400
Action type	Type	Code			
	Instantaneous time	Q20	Q10	S20	S10
	Delay time 1s	Q21	Q11	S21	S11
	Delay time 3s	Q23	Q13	S23	S13
	Delay time 5s	Q25	Q15	S25	S15
Action voltage (V)		(0.35-0.7) Ue		(0.1-0.35) Ue	
Guarantee the reliable closing voltage (V)		(0.85-1.1) Ue			
Not guarantee the reliable closing voltage		≤ 0.35Ue			
Power consumption		15VA			

**Note:** In thunderstorm prone areas or power grids with unstable power supply voltage, it is recommended to use undervoltage tripping with delay to prevent circuit breaker tripping due to short-term voltage drop. The delay time is generally 1S, 3S, 5S

### Undervoltage release

Rated insulation voltage(Ui)	Rated control supply voltage(Us)	Instantaneous power		Maintained power	
		VW3-20 (S/H)	VW3-25 (H/HU/HV) VW3-40 (H/HU/HV) VW3-63 (H/HU/HV)	VW3-20 (S/H)	VW3-25 (H/HU/HV) VW3-40 (H/HU/HV) VW3-63 (H/HU/HV)
400V	AC380V/AC400V	180W	115W	3.8W	3.6W
	AC220V/AC230V	148W	118W	2.4W	3.4W

### Loss-of-voltage release

Rated insulation voltage(Ui)	Rated control supply voltage(Us)	Instantaneous power		Maintained power	
		VW3-20 (S/H)	VW3-25 (H/HU/HV) VW3-40 (H/HU/HV) VW3-63 (H/HU/HV)	VW3-20 (S/H)	VW3-25 (H/HU/HV) VW3-40 (H/HU/HV) VW3-63 (H/HU/HV)
400V	AC380V/AC400V	650W	280W	0.43W	6.36W
	AC220V/AC230V	440W	105W	0.36W	3.24W

## Grid Undervoltage (loss-of voltage) release



Suitable for distributed PV low-voltage grid connection, achieving voltage loss tripping, overvoltage tripping, and automatic closing upon voltage detection.

Action value of loss-of voltage: $\leq 20\%U_e$	Action delay time of loss-of voltage: 1-10s
Action value of overvoltage: $\geq 135\%U_n$	Automatic closing voltage: (0.85-1.1)U <sub>e</sub>

**Note:** 1. X1 and X2 only send a short signal (200ms) after overvoltage(loss-of-voltage) release recover for 1 second, then the closed electromagnet act.  
2. The number in the box represents the secondary wiring terminal number. N represents the terminal number of VW3-20 (S/H) circuit breaker, and H&S represents the terminal number of VW3-25 (H/HU/HV), VW3-40 (H/HU/HV), VW3-63 (H/HU/HV).

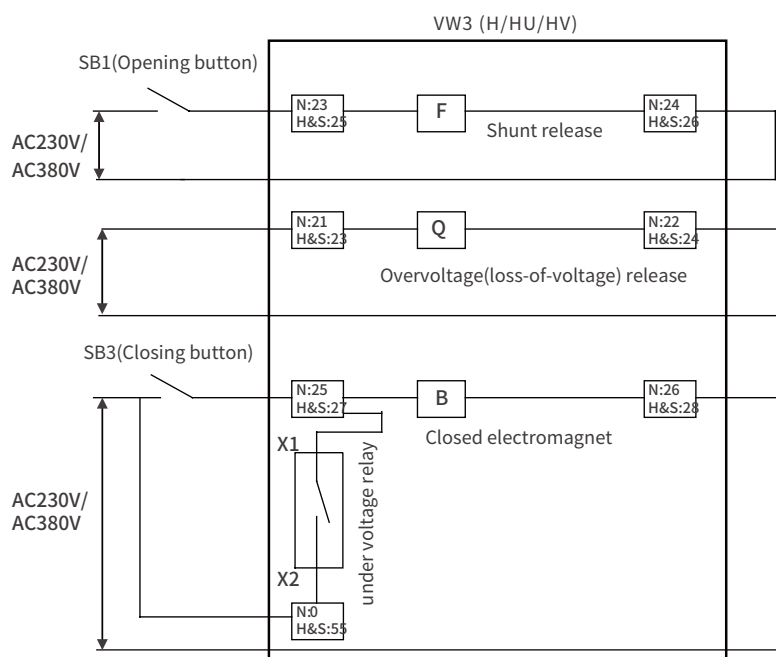

## Lock

### Off-position key lock (SF11,SF21,SF31,SF32,SF53)

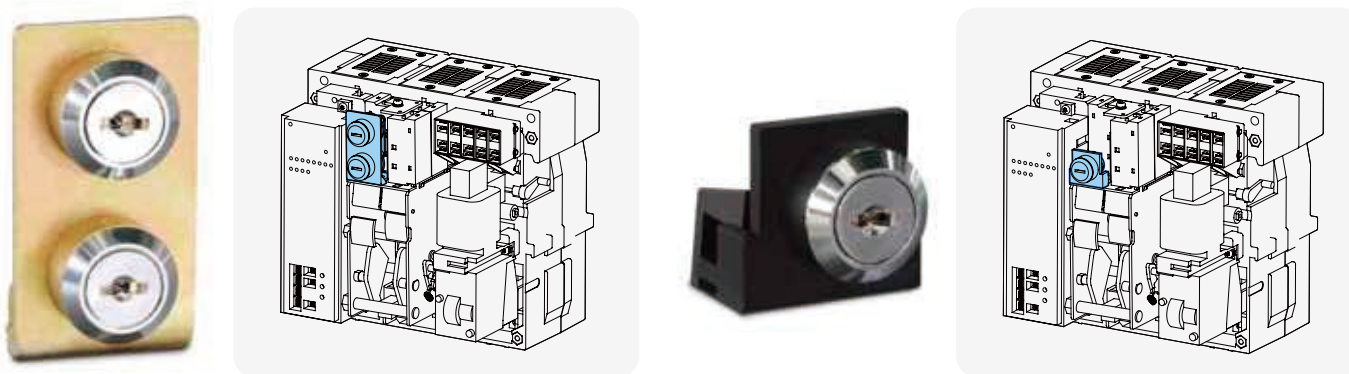

This key lock is locked on the manually disconnected position of the circuit breaker

#### Key lock :

- One lock one key (SF11): One circuit breaker with one lock and one key, and not allowed to closed when locked
- Two locks one key (SF21): Two circuit breakers with two same lock and one key, and only allowed one circuit breaker closed
- Three locks one key (SF31): Three circuit breakers with three same lock and one key, and only allowed one circuit breaker closed
- Three locks two keys (SF32): Three circuit breakers with three same lock and two keys, and only allowed two circuit breakers closed
- Five locks three keys (SF53): Five circuit breakers with five same lock and three keys, and only allowed three circuit breakers closed

## Mechanical interlocking (SR11,SR12,SR21,SY11)

Circuit figure Possible operating modes

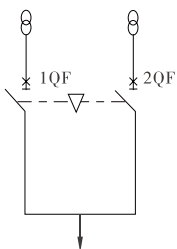

1QF	2QF
0	0
0	1
1	0

Two interlocking cables circuit breakers or two interlocking hard rods circuit breakers

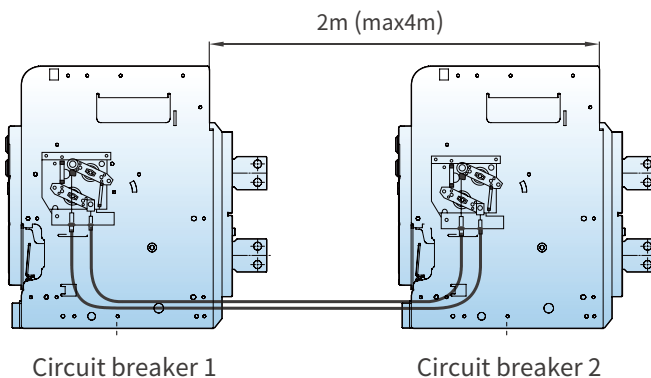

Circuit figure Possible operating modes

Mode 1: Three power supplies can only close one circuit breaker

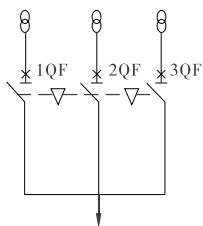

1QF	2QF	3QF
0	0	0
1	0	0
0	1	0
0	0	1

Three circuit breaker interlocking hard rods

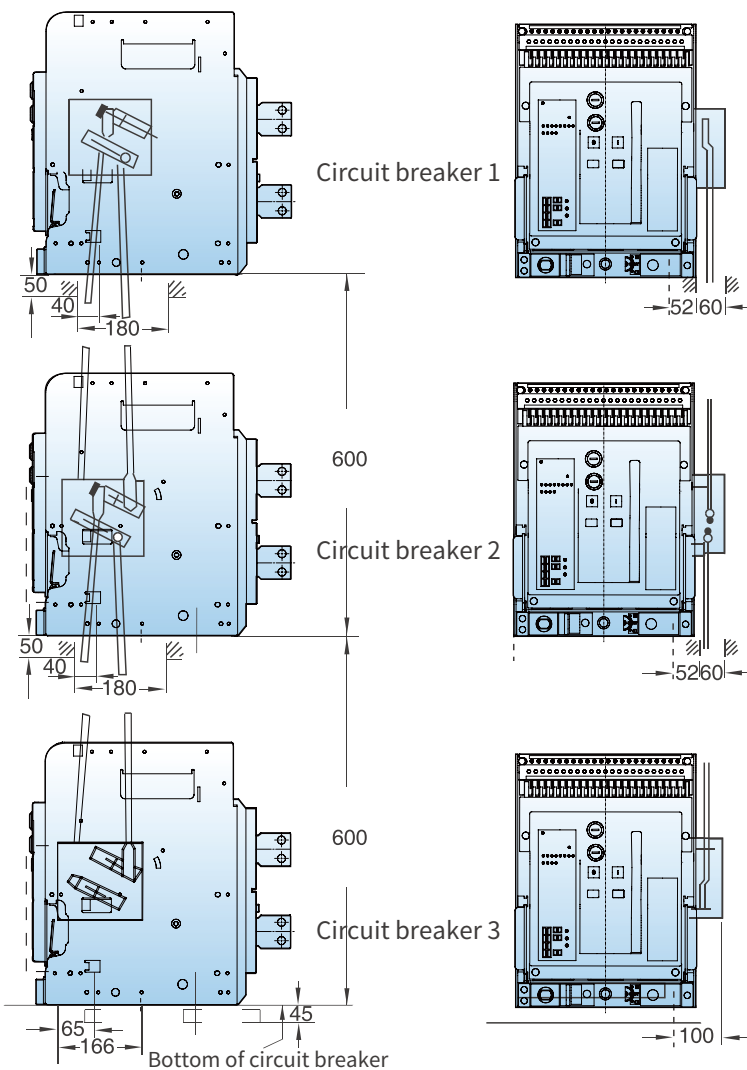

## Button lock (S) (The minimum safety distance 35mm between the cases)

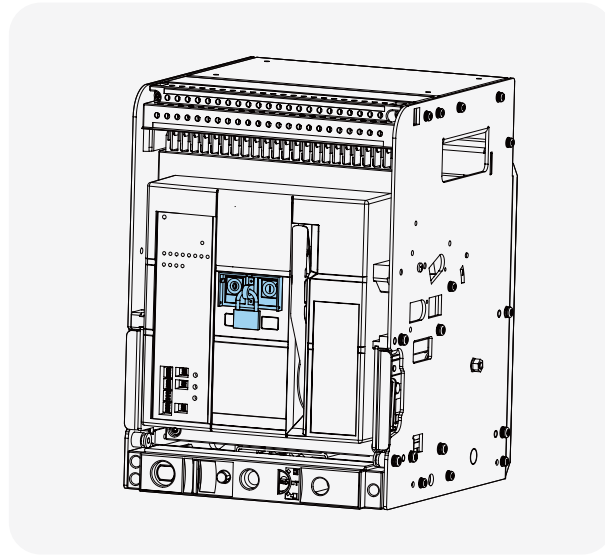
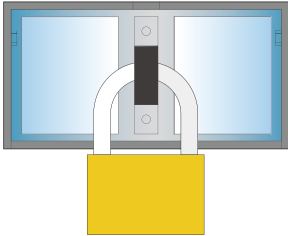

## Door interlock (The minimum safety distance 40mm between the circuit breaker)

When the circuit breaker at the working or testing position, prohibited to open the cabinet door; The door is opened and the circuit breaker at the connected position, close the door without disconnecting the circuit breaker.

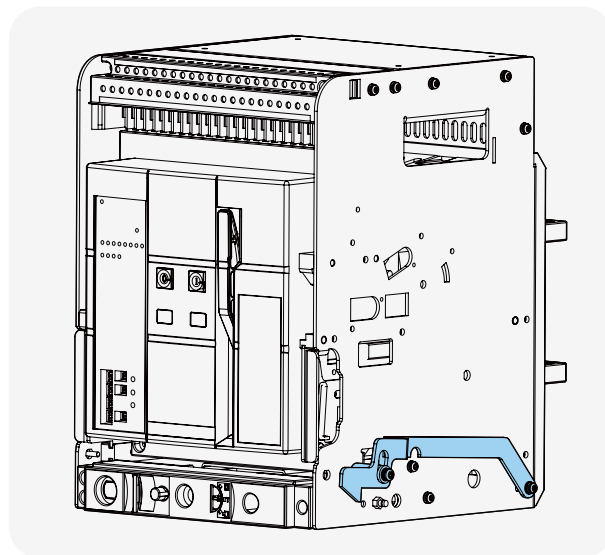
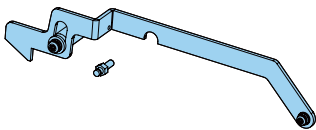

**Drawer type circuit breaker locking device at "separation" position**



When the drawer type circuit breaker at the separated position, lock the circuit breaker by pull out the rod. After locking, the circuit breaker will not be able to "test" and "connection" positions.

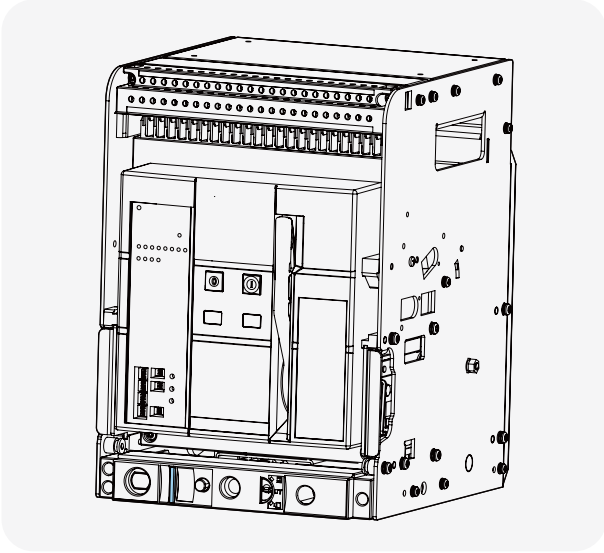

**Phase separator** (The minimum safety distance 180mm between the circuit breakers)

The minimum safety distance 100mm between VW3-20 (S/H), and The minimum safety distance 180mm between VW3-25 (H/HU/HV), VW3-40 (H/HU/HV), VW3-63 (H/HU/HV).

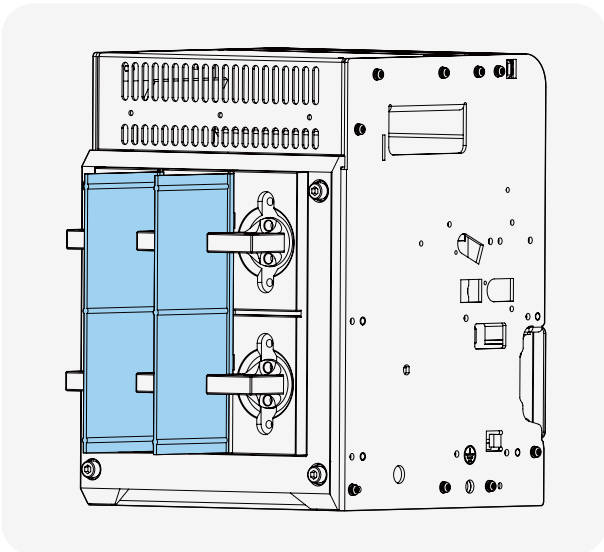
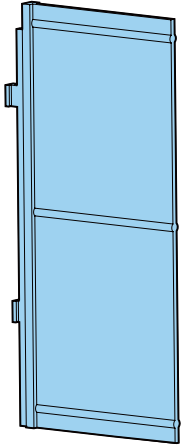

**Doorframe(M)**

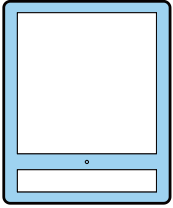

Have the fixed type and drawout type, it is mainly placed on the door of the cubicle for sealing, and can make the protection level of the circuit breaker reaches IP40. It is beautiful and practical.

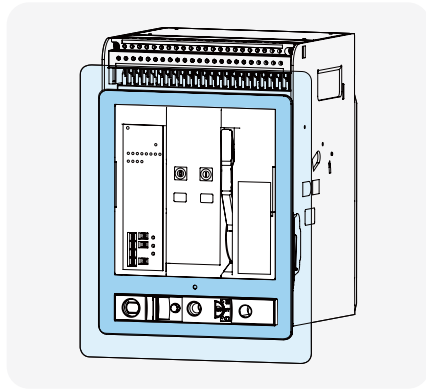

**Position indication(CX)** (The minimum safety distance 50mm between the circuit breakers)

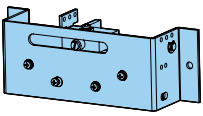

With three contacts to indicate the position status of the circuit breaker (connection, testing, separation). When the circuit breaker is in a certain position, the corresponding contact will be closed.

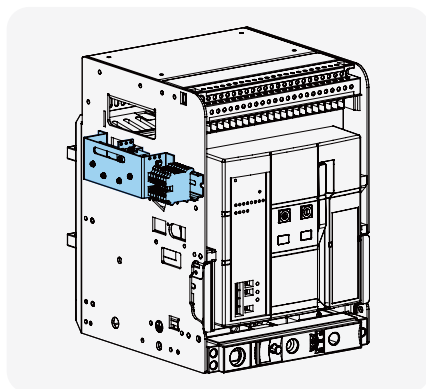

**Power supply module** (The minimum safety distance 60mm between the circuit breakers)

AC65~500V, DC80~700V

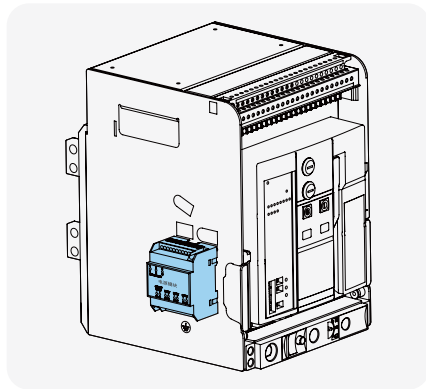
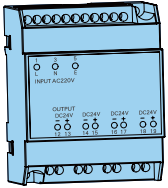

### External neutral current transformer (N)

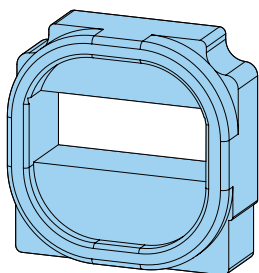

The TN-S distribution system use the three pole circuit breaker and requires an external neutral current transformer.  
 The earth current protection type distribution system use the three pole circuit breaker and requires an external neutral current transformer.  
 The installation cautions as follows:

1. The external neutral current transformer has a twisted pair wire with codes 6 and 7 ,connect to same terminal code of the secondary terminal
- 2.The installation direction of the external neutral current transformer depends on the wiring method of the circuit breaker:  
 If the line of the circuit breaker upper , the convex surface of the external neutral current transformer should face the neutral grounding point side;  
 If the line of the circuit breaker down , the plane surface of the external neutral current transformer should face the neutral grounding point side;
3. Current transformer type based on the width of the N-phase busbar

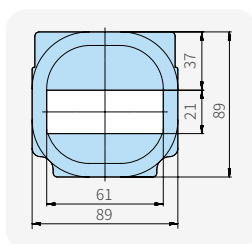
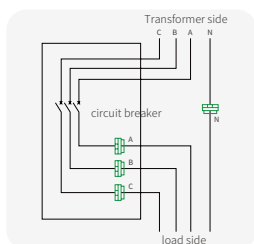

N1

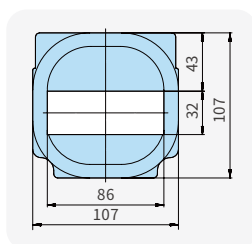

N2

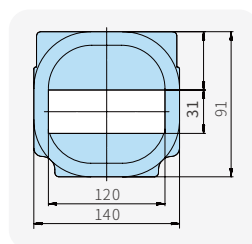

N3

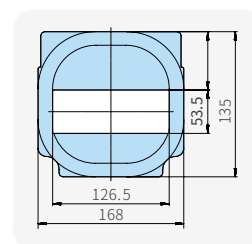

N4

### External leakage current transformer

When the residual current protection function, required an external residual current transformer, and the controller does not have the ground protection function.  
 The external neutral current transformer has a twisted pair wire with codes 6 and 7 ,connect to same terminal code of the secondary terminal  
 The principle of residual current protection is shown in the following figure



#### Outline Dimension

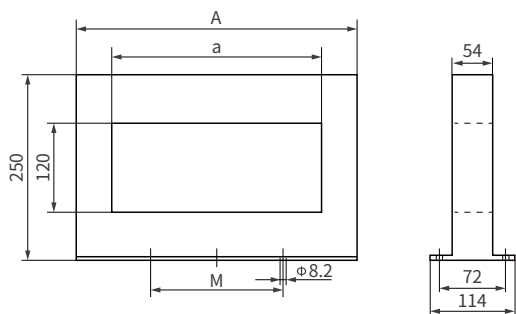

	A	M	a
Type I	380	250	285
Type II	465	250	370
Type III	595	350	500

## Power consumption (ambient air temperature +40°C)

Power consumption is the total Power consumption which measured at the circuit breaker frame rated current  $I_{nm}$

Type	Power consumption (W)	
	Fixed type	Drawout type
VW3-20(S/H)	123.5	331.5
VW3-25(H/HU/HV)	356.8	823.4
VW3-40(H/HU/HV)	486.7	856.8
VW3-63(H/HU/HV)	787	1145

## Temperature derated coefficient

If the ambient temperature is higher than +40°C, capacity can be corrected according to the following table

Type	Rated current (A)	+40°C	+45°C	+50°C	+55°C	+60°C	+65°C	+70°C
VW3-20(S/H)	200~1250	1	1	1	1	1	1	1
	1600~2000	1	1	1	1	0.98	0.93	0.87
VW3-25(H/HU/HV)	630~2000	1	1	1	1	1	1	1
	2500	1	1	1	1	0.99	0.94	0.88
VW3-40(H/HU/HV)	1000~2500	1	1	1	1	1	1	1
	2900	1	1	1	1	1	0.96	0.94
	3200	1	1	1	1	0.94	0.92	0.90
	3600	1	1	1	0.94	0.92	0.90	0.85
	4000	1	0.95	0.92	0.89	0.85	0.85	0.80
VW3-63(H/HU/HV)	4000~5000	1	1	1	1	1	1	1
	6300	1	1	0.98	0.93	0.89	0.85	0.82

If the altitude is higher than 2000m, capacity can be corrected according to the following table

Altitude (m)		2000	3000	4000	4500	5000
Power-frequency withstand voltage(V)		5000	4500	4000	3700	3500
Rated impulse withstand voltage $U_{imp}$ (kV)		18	15	15	12	12
Correction coefficient for short-circuit breaking capacity		1	0.98	0.93	0.88	0.85
Correction coefficient for working current	VW3-20(S/H)	1	0.98	0.93	0.9	0.87
	VW3-25(H/HU/HV)	1	1	1	1	0.97
	VW3-40(H/HU/HV)	1	0.93	0.88	0.85	0.82
	VW3-63(H/HU/HV)	1	0.98	0.93	0.90	0.87

The derating correction factor is only applicable to the maximum current of the shell frame

## Copper busbar specification

Frame size rated current $I_{nm}$ (A)	Rated current $I_n$ (A)	Copper busbar specification		
		Number of busbar		Dimension
		Horizontal wiring	Vertical wiring	
VW3-20(S/H)	≤630	1		50×5
	800	1		50×10
	1000	1		50×10
	1250	2		50×10
	1600	2		50×10
	2000	3		60×10
VW3-25(H/HU/HV)	630	2	/	80×5
	800	2	/	80×5
	1000	2	/	80×5
	1250	3	/	80×5
	1600	2	/	80×10
	2000	3	/	80×10
	2500	3	/	80×10
VW3-40(H/HU/HV)	1000	2	1	80×5
	1250	3	2	80×5
	1600	2		80×10
	2000	3	2	80×10
	2500	3		80×10
	2900	3		100×10
	3200	4		100×10
	3600	5	4	100×10
VW3-63(H/HU/HV)	4000	5	4	100×10
	5000	7	5	100×10
	6300	10	8	100×10

The table indicates the copper busbar specifications adopted when the circuit breaker is under the ambient temperature of 40°C and the open wide installation under the heating condition meets the stipulation in GB14048.2.

### Recommended screw used of outlet busbar diameter

Circuit breaker type	Outlet busbar diameter	Screws grade 8.8 (with washer)	Tightening torque
VW3-20(S/H)	Φ11	M10	50N.m
VW3-25 (H/HU/HV) VW3-40(H/HU/HV) VW3-63 (H/HU/HV)	Φ13	M12	70N.m

## VW3-20(S/H) Electrical Wiring Diagram

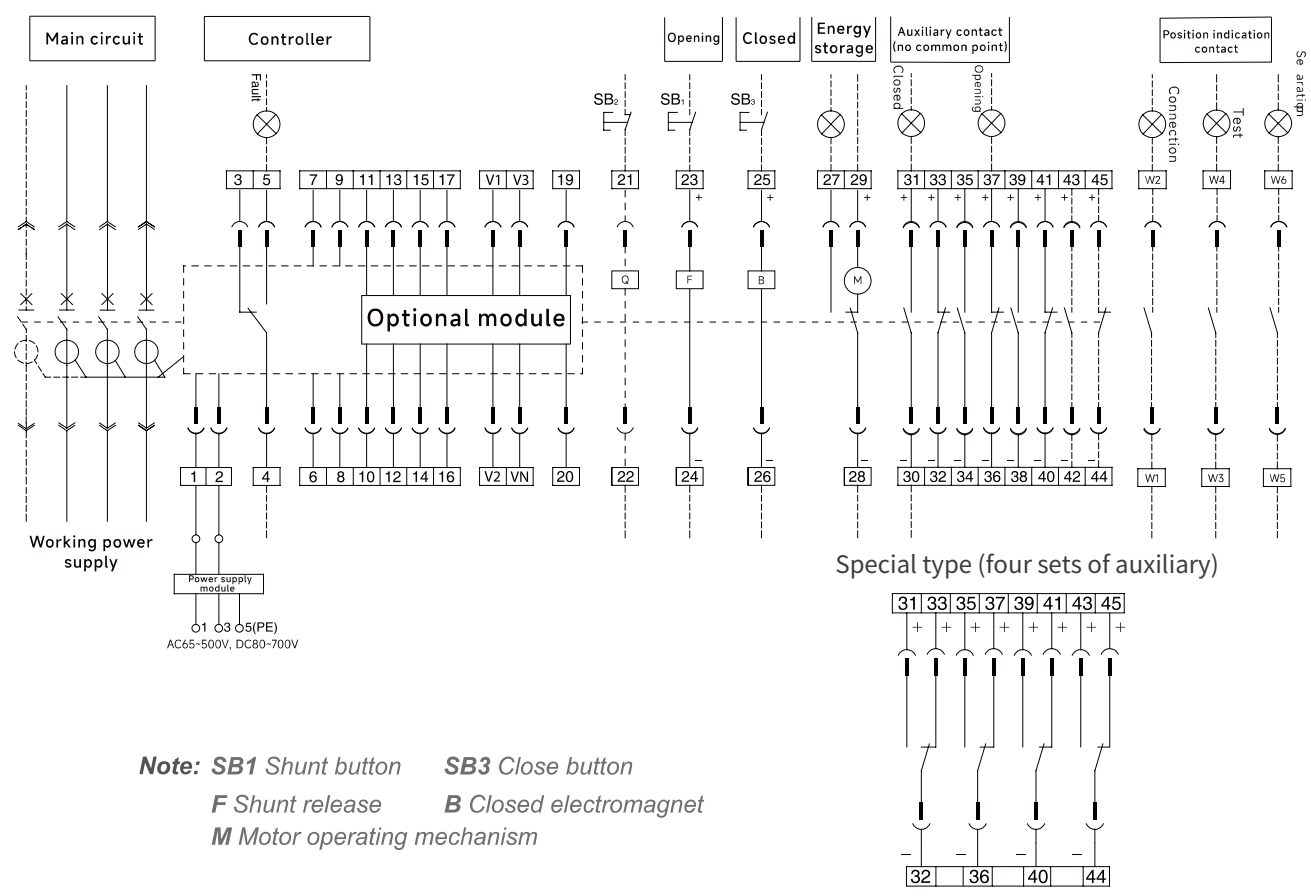

### Terminal Number

1#, 2#	Working power supply	21#, 22#	Under-voltage release or loss of voltage release
3#, 4#, 5#	Fault tripping contact output	23#, 24#	Shunt release
6#, 7#	External transformer or external leakage current transformer	25#, 26#	Closed electromagnet
8#, 9#	Communication	27#, 28#, 29#	Motor operating mechanism
10#, 11#	First contact output	30#~45#	Auxiliary contact
12#, 13#	Second contact output	V1	A-phase wiring (input voltage ≤ 230V)
14#, 15#	Third contact output	V2	B-phase wiring (input voltage ≤ 230V)
16#, 17#	Fourth contact output	V3	C-phase wiring (input voltage ≤ 230V)
19#	Communication shielded grounding wire	VN	N-phase wiring
20#	PE-phase wiring	/	/

- Note:** (1) Position contact terminal numbers W1 # -W6 # do not connect the secondary terminal  
 (2) If the control power supply voltage of F, B and M is different, connect to different power sources separately  
 (3) Terminals 29 # (VW3-20S/VW3-20H) can be directly connect to the power supply (automatic pre energy storage), or can be connect to the power supply after the normally open button (manual pre energy storage)  
 (4) Indicator light, button switch are provided by user  
 (5) Select the contact output function according to the "DO Function Setting Table" on page 42  
 (6) The above circuit diagrams is the circuit breaker in the open position.  
 (7) The shunt release coil is of the long-term energized type and defaults to the pulse type. If choose to maintain type coil, please contact the manufacturer.  
 (8) When connecting the auxiliary contact to a load, please keep the load in the same position and direction as the auxiliary contact, otherwise it may cause the auxiliary contact to burn out. Do not connect the normally closed contacts of this machine in series with the closed coil, otherwise it will cause anti bounce failure.

## With communication function

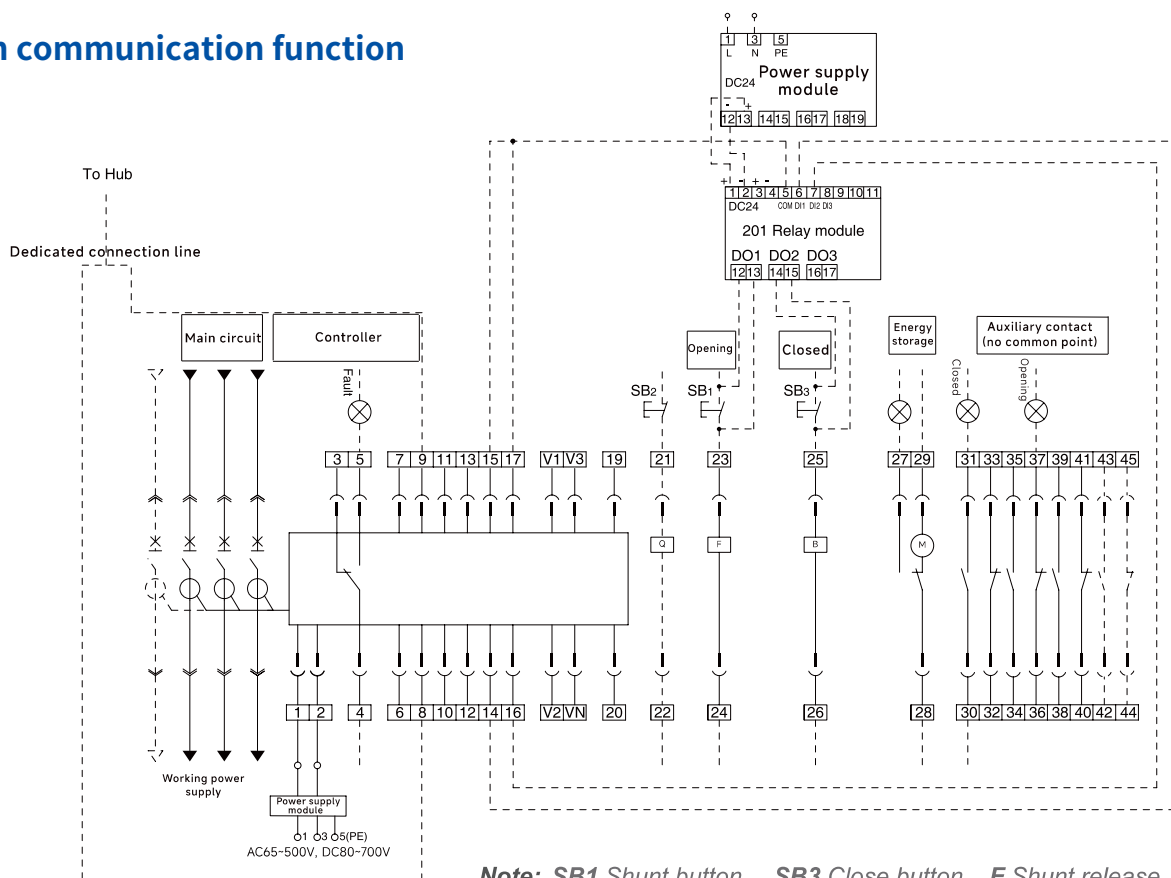

**Note:** SB1 Shunt button    SB3 Close button    F Shunt release  
 B Closed electromagnet    M Motor operating mechanism

Terminal Number			
1#, 2#	Working power supply	21#, 22#	Under-voltage release or loss of voltage release
3#, 4#, 5#	Fault tripping contact output	23#, 24#	Shunt release
6#, 7#	External transformer or external leakage current transformer	25#, 26#	Closed electromagnet
8#, 9#	Communication	27#, 28#, 29#	Motor operating mechanism
10#, 11#	First contact output	30#~45#	Auxiliary contact
12#, 13#	Second contact output	V1	A-phase wiring (input voltage ≤ 230V)
14#, 15#	Third contact output	V2	B-phase wiring (input voltage ≤ 230V)
16#, 17#	Fourth contact output	V3	C-phase wiring (input voltage ≤ 230V)
19#	Communication shielded grounding wire	VN	N-phase wiring
20#	PE-phase wiring	/	/

- Note:**
- (1) Position contact terminal numbers W1# - W6# do not connect the secondary terminal
  - (2) If the control power supply voltage of F, B and M is different, connect to different power sources separately
  - (3) Terminals 29# (VV3-20S/VV3-20H) can be directly connect to the power supply (automatic pre energy storage), or can be connect to the power supply after the normally open button (manual pre energy storage)
  - (4) Indicator light, button switch are provided by user
  - (5) Select the contact output function according to the "DO Function Setting Table" on page 42
  - (6) The above circuit diagrams is the circuit breaker in the open position.
  - (7) The shunt release coil is of the long-term energized type and defaults to the pulse type. If choose to maintain type coil, please contact the manufacturer.
  - (8) When connecting the auxiliary contact to a load, please keep the load in the same position and direction as the auxiliary contact, otherwise it may cause the auxiliary contact to burn out. Do not connect the normally closed contacts of this machine in series with the closed coil, otherwise it will cause anti bounce failure.

# Size and Connection

## VW3-25(H/HU/HV), VW3-40(H/HU/HV), VW3-63(H/HU/HV) Electrical Wiring Diagram

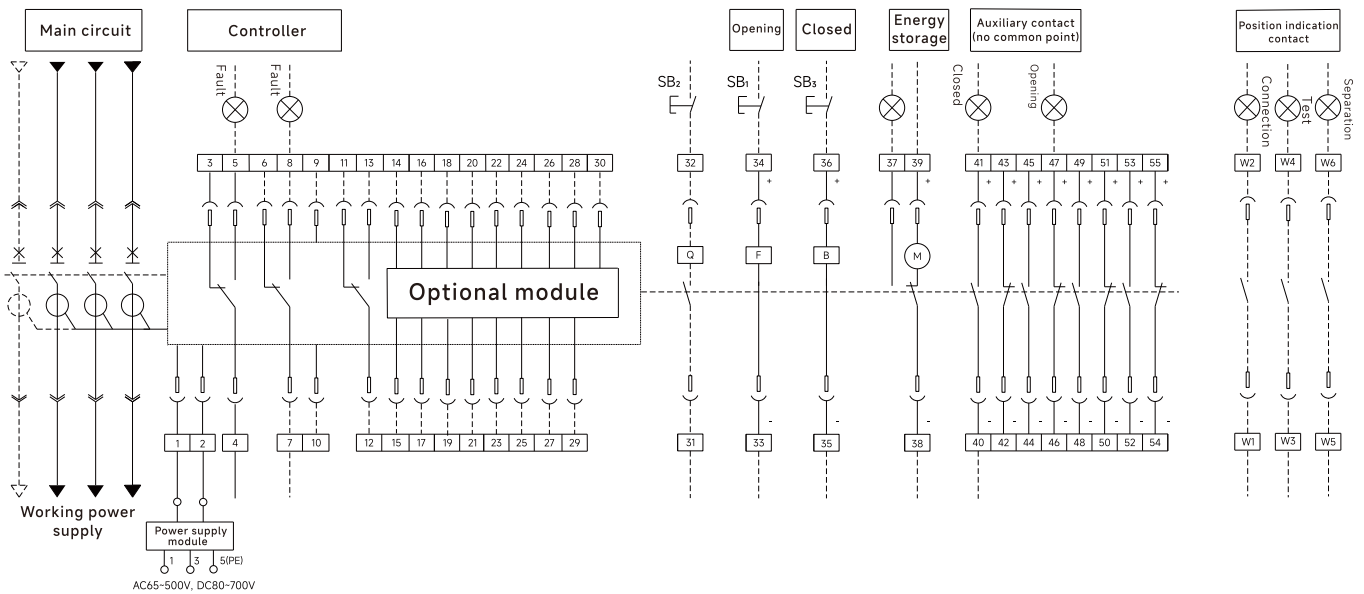

## With communication function

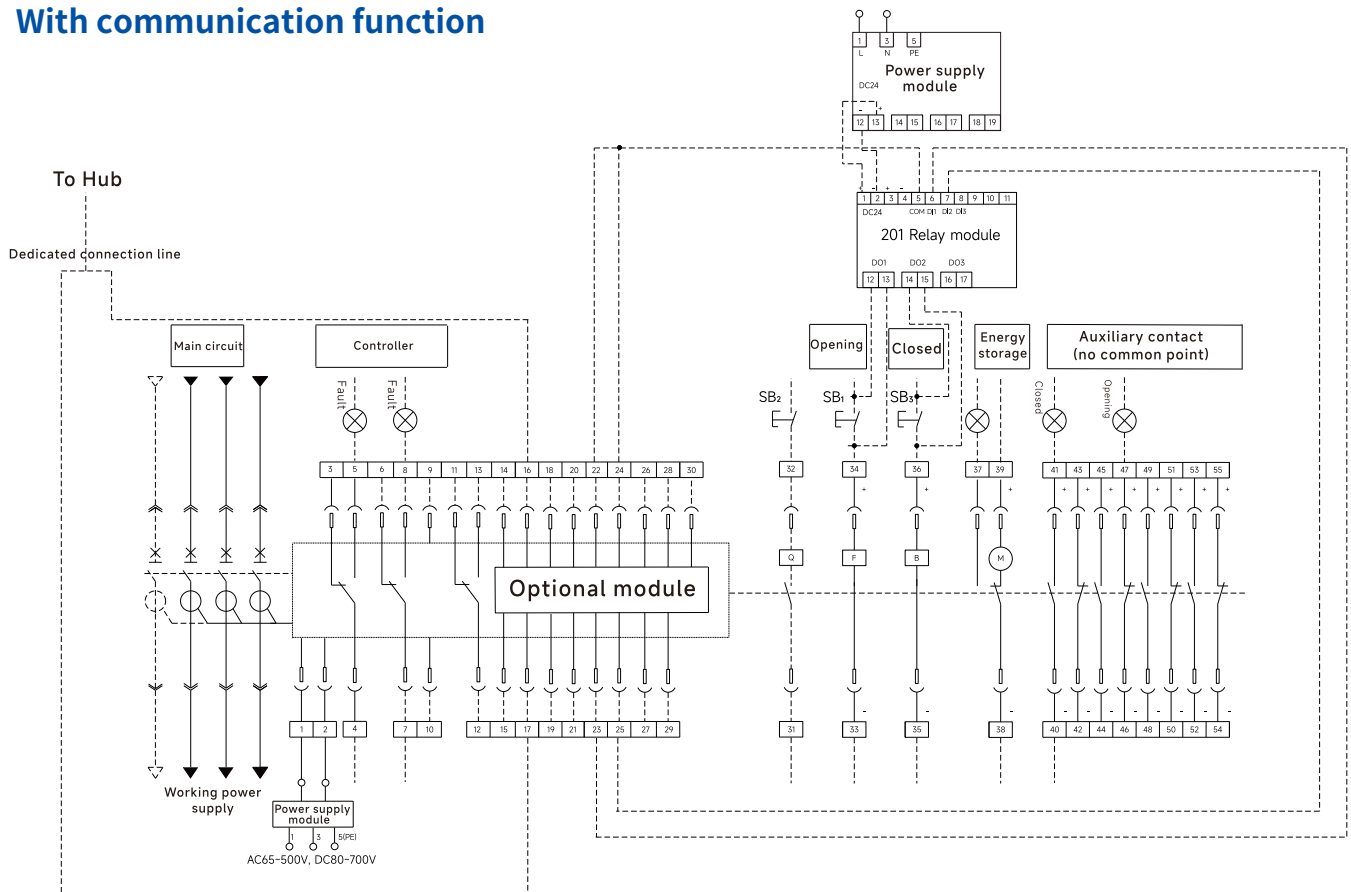

## Special (four sets of auxiliary)

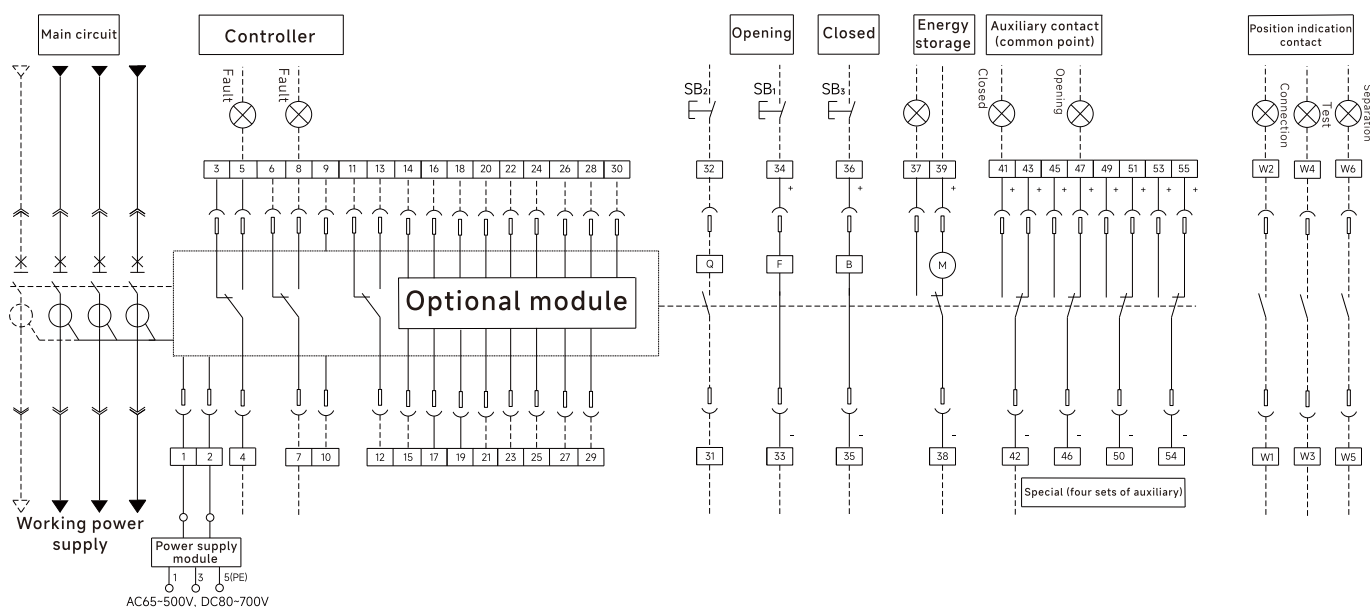

**Note:** SB1 Shunt button    SB3 Close button    F Shunt release    B Closed electromagnet    M Motor operating mechanism

Terminal Number			
1#, 2#	Working power supply	26#	A-phase wiring (input voltage ≤ 230V)
3#, 4#, 5#	Fault tripping contact output 1	27#	B-phase wiring (input voltage ≤ 230V)
6#, 7#, 8#	Fault tripping contact output 2	28#	C-phase wiring (input voltage ≤ 230V)
9#, 10#	Remote reset	29#	N-phase wiring
11#, 12#, 13#	Close ready signal output unit	30#	PE-phase wiring
14#, 15#	External transformer or external leakage current transformer	31#, 32#	Under-voltage release or loss of voltage release
16#, 17#	Communication	33#, 34#	Shunt release
18#, 19#	First contact output	35#, 36#	Closed electromagnet
20#, 21#	Second contact output	37#, 38#, 39#	Motor operating mechanism
22#, 23#	Third contact output	40#-55#	Auxiliary contact
24#, 25#	Fourth contact output	/	/

- Note:**
- (1) Position contact terminal numbers W1 # -W6 # do not connect the secondary terminal
  - (2) If the control power supply voltage of F, B and M is different, connect to different power sources separately
  - (3) Terminals 39 # (VW3-25H/VW3-40H/VW3-63H) can be directly connect to the power supply (automatic pre energy storage), or can be connect to the power supply after the normally open button (manual pre energy storage)
  - (4) Indicator light, button switch are provided by user
  - (5) Select the contact output function according to the "DO Function Setting Table" on page 1-23
  - (6) The above circuit diagrams is the circuit breaker in the open position.
  - (7) The shunt release coil is of the long-term energized type and defaults to the pulse type. If choose to maintain type coil, please contact the manufacturer.

## Drawout type (VW3-20S/VW3-20H)

Front view

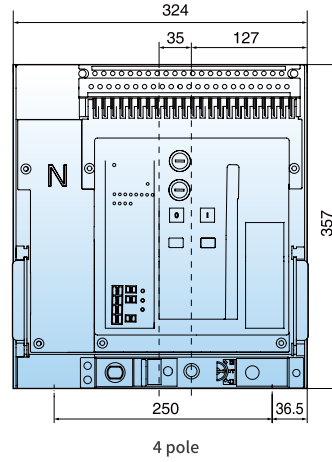
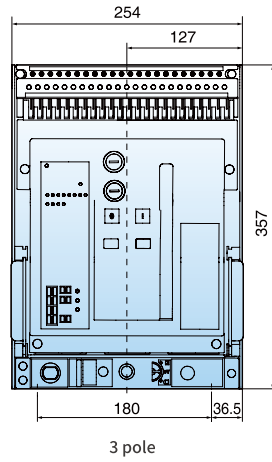

Vertical Wiring

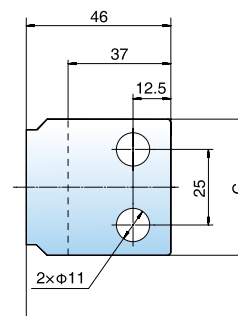
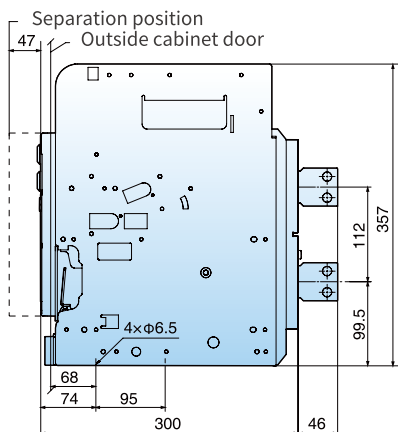
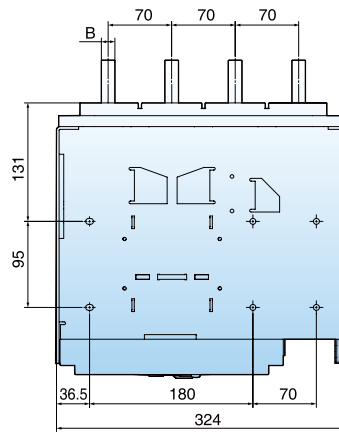
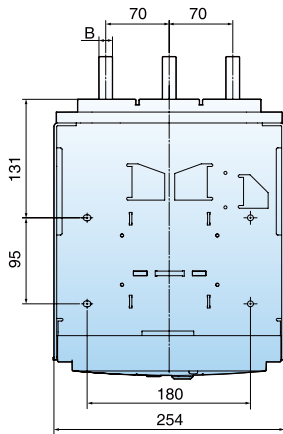

# Size and Connection



## Horizontal Wiring

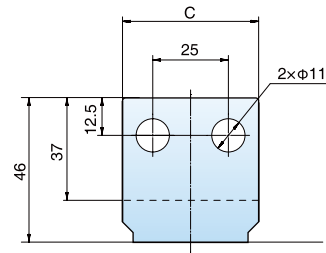
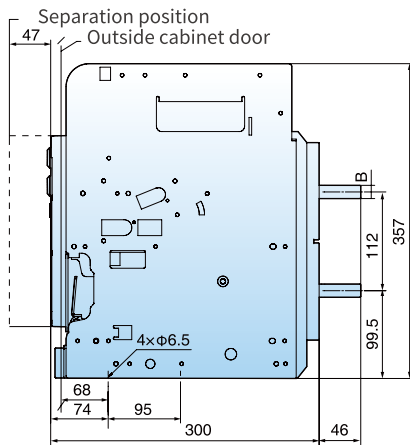
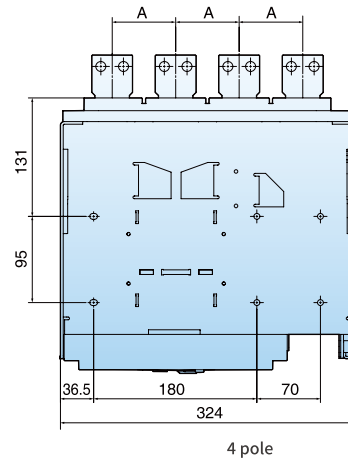
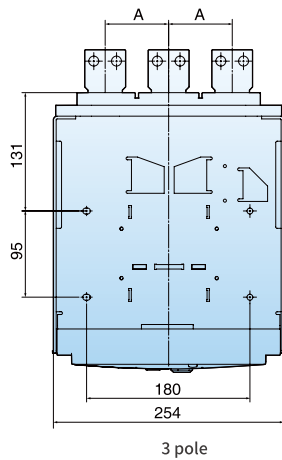

Current	VW3-20 (200~630A)	VW3-20 (800~1250A)	VW3-20 (1600A)	VW3-20 (2000A)
Dimension A (mm)	70	70	70	3P:85/4P:80
Dimension B (mm)	5	10	15	15
Dimension C (mm)	45	45	45	60

## Cabinet door open hole dimension

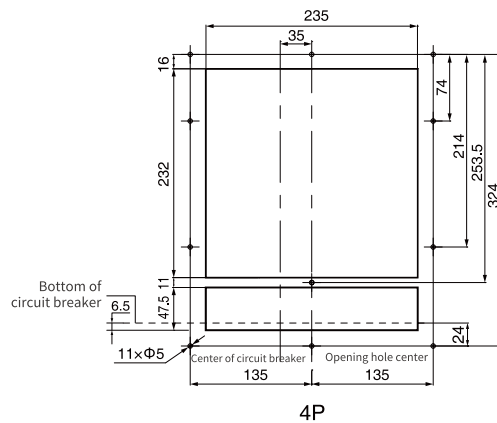
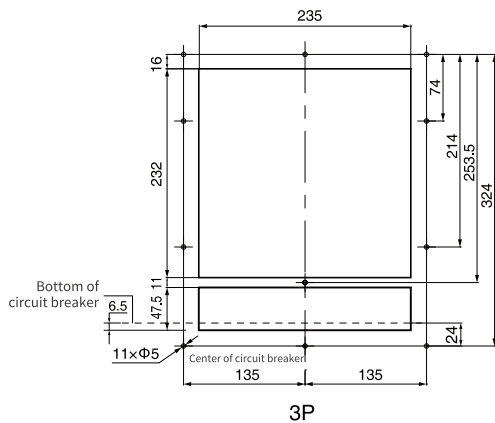

# Size and Connection



## Fixed type (VW3-20S/VW3-20H)

Front view

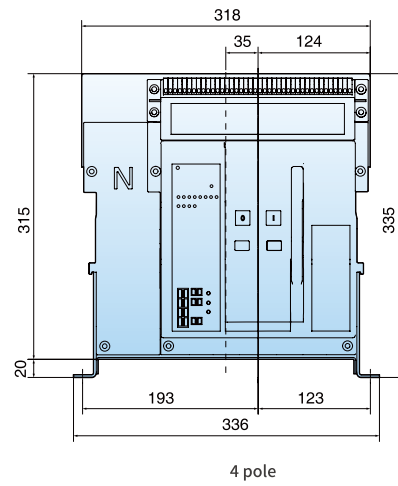
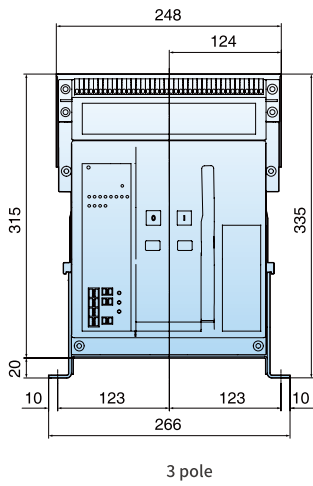

Vertical Wiring

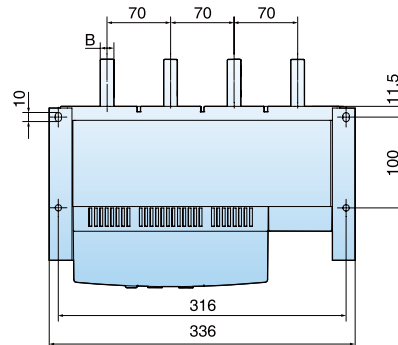
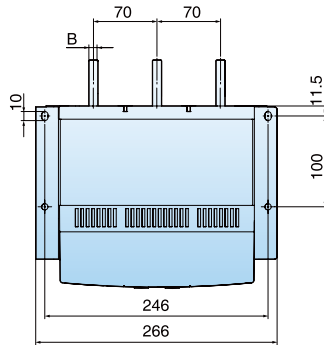

Distance for dismantling the arc extinguishing chamber

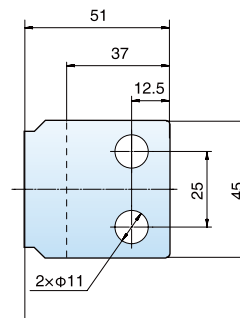
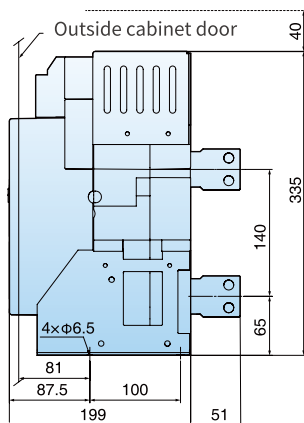

# Size and Connection



## Vertical Wiring

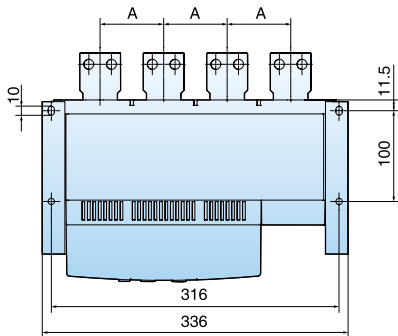
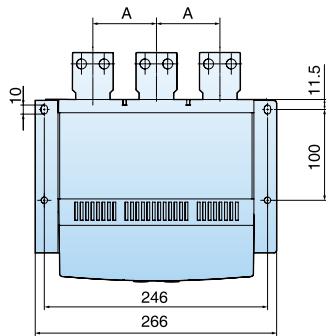

Distance for dismantling the arc extinguishing chamber

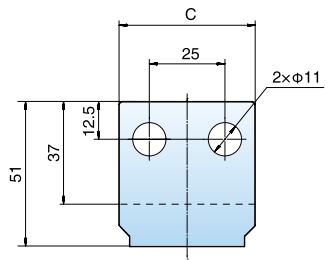
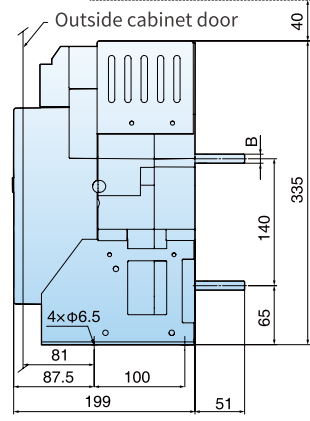

Current	VW3-20 (200~630A)	VW3-20 (800~1250A)	VW3-20 (1600A)	VW3-20 (2000A)
Dimension A (mm)	70	70	70	3P:85/4P:80
Dimension B (mm)	5	10	15	15
Dimension C (mm)	45	45	45	60

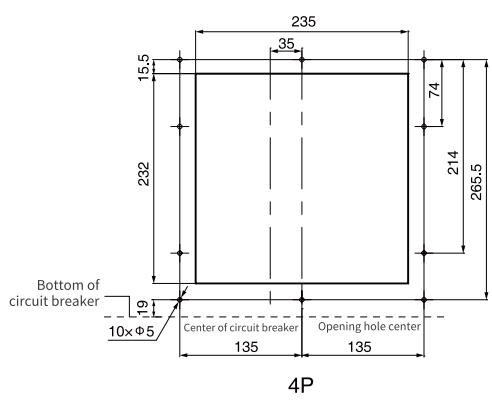
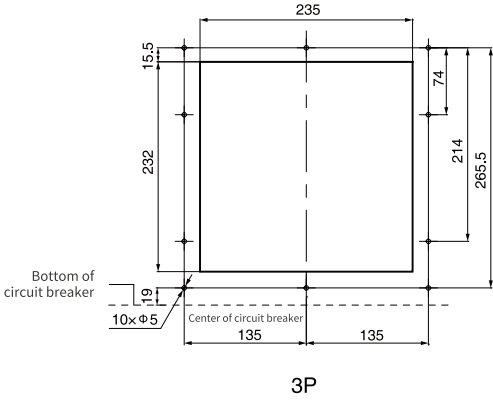

# Size and Connection



## Drawout type (VW3-25H/VW3-25HU/VW3-25HV)

Front view

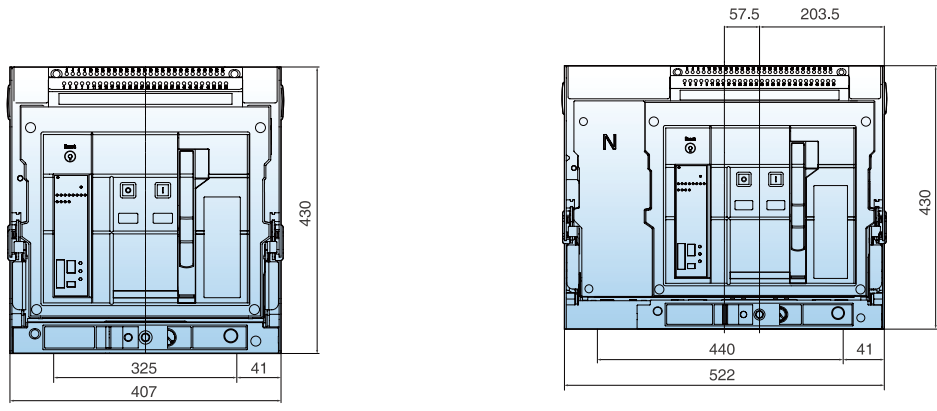

Horizontal Wiring

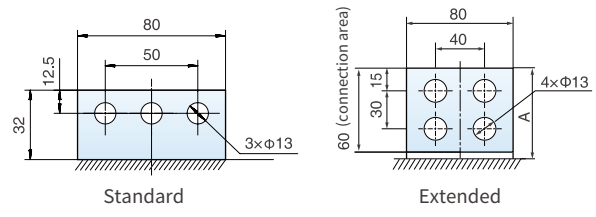
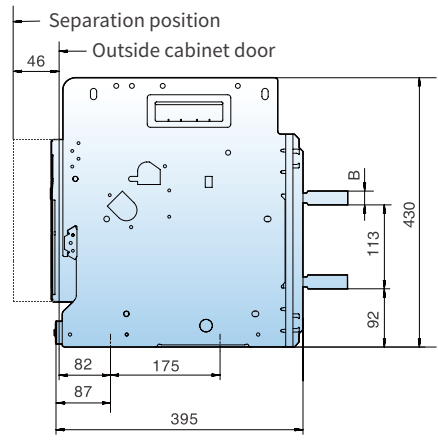
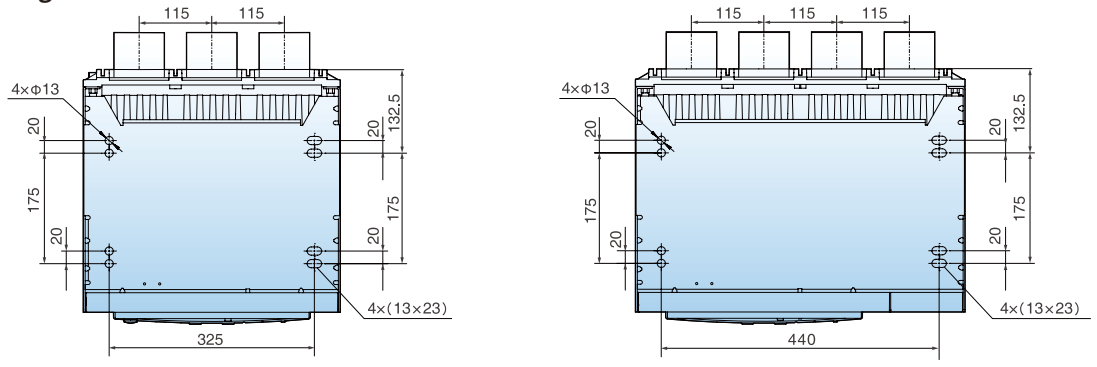

Current	VW3-25H (630~1600A)	VW3-25H (2000~2500A)
Dimension A(mm)	65	75
Dimension B(mm)	10	20

Cabinet door open hole dimension

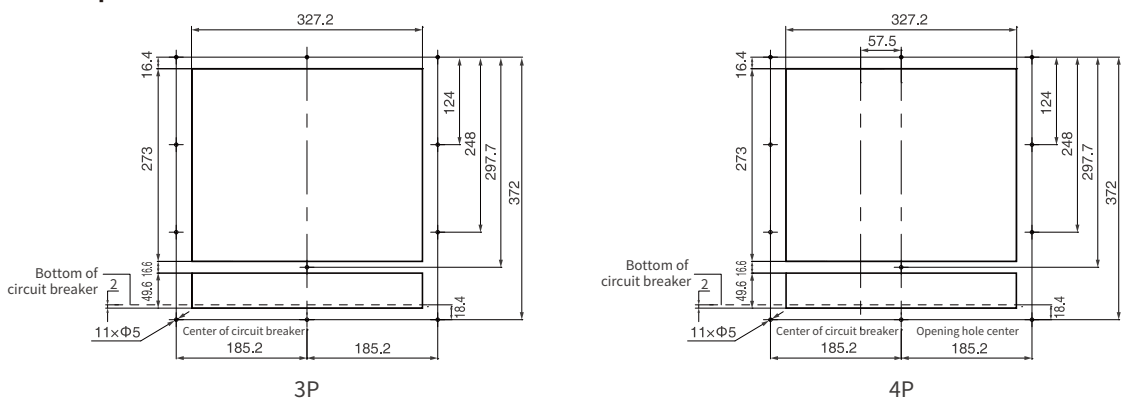

# Size and Connection



## Fixed type (VW3-25H/VW3-25HU/VW3-25HV)

### Front view

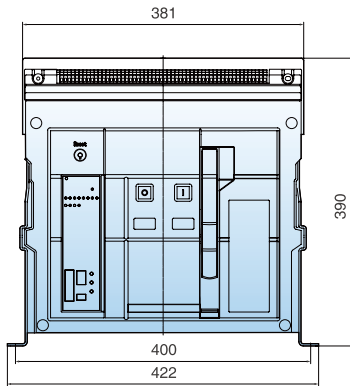

3 pole

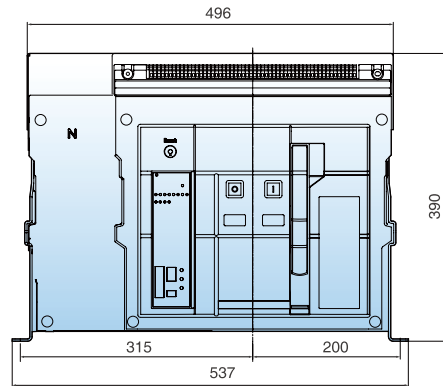

4 pole

### Horizontal Wiring

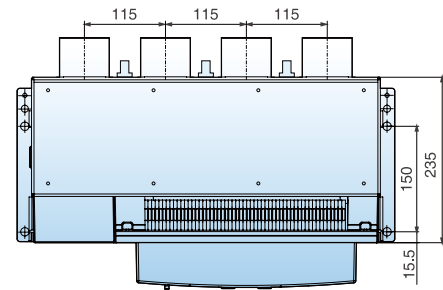
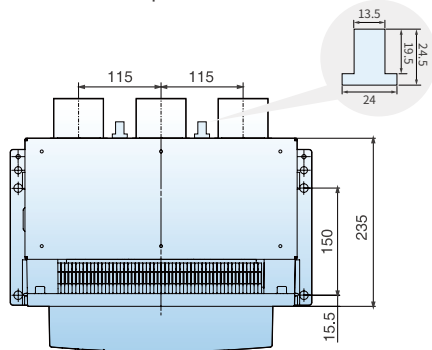

Distance for dismantling the arc extinguishing chamber

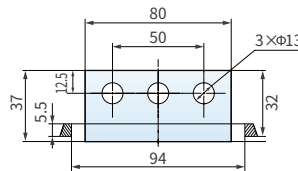
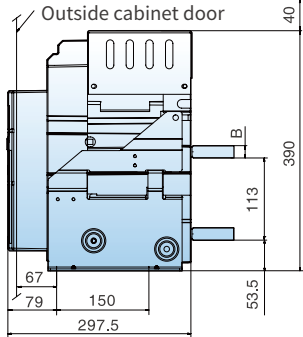

Standard

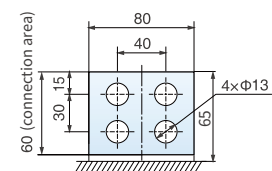

Extended

Current	VW3-25H (630~1600A)	VW3-25H (2000~2500A)
Dimension B(mm)	10	20

### Cabinet door open hole dimension

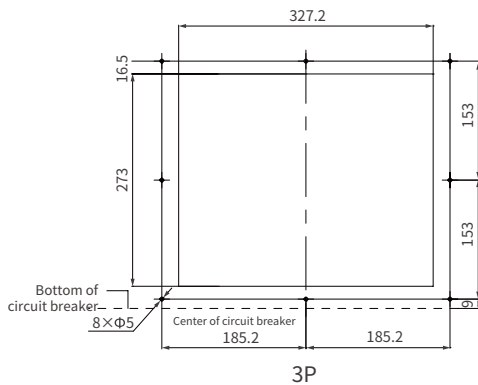

3P

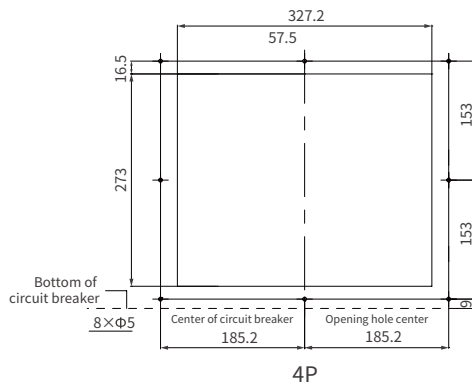

4P

## Drawout type (VW3-40H/VW3-40HU/VW3-40HV, 1000~3200A)

### Front view

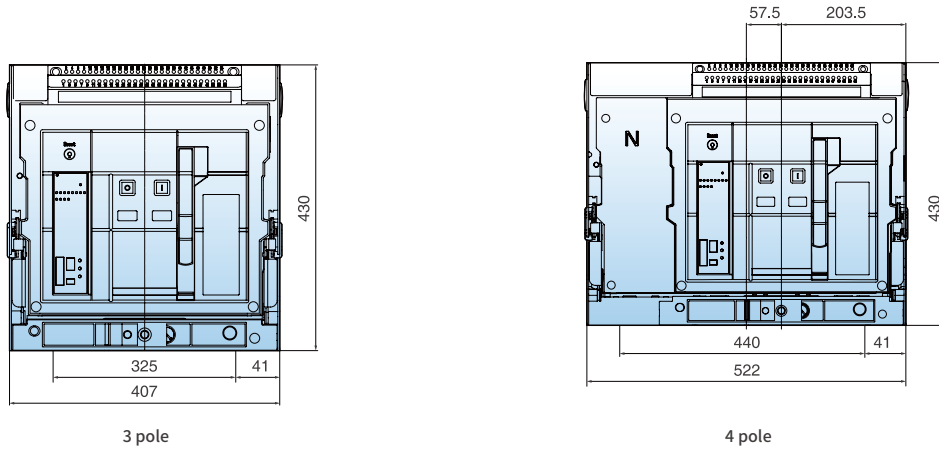

### Vertical Wiring

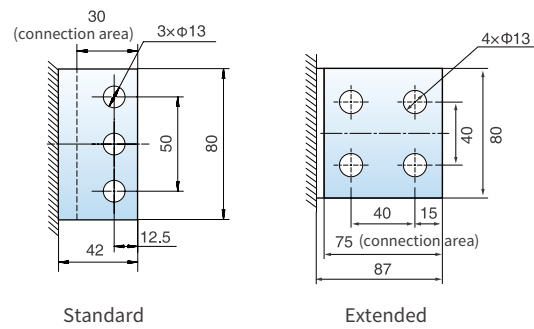
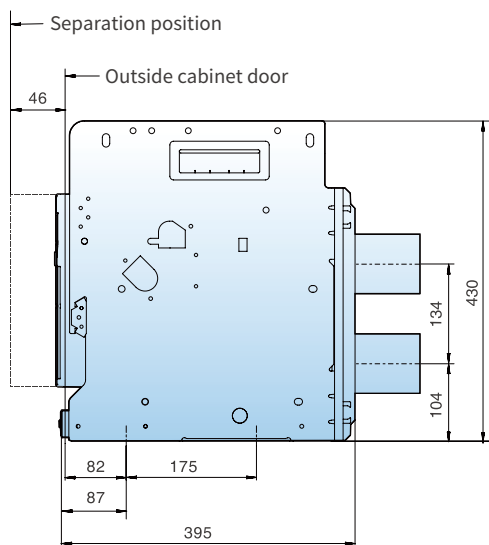
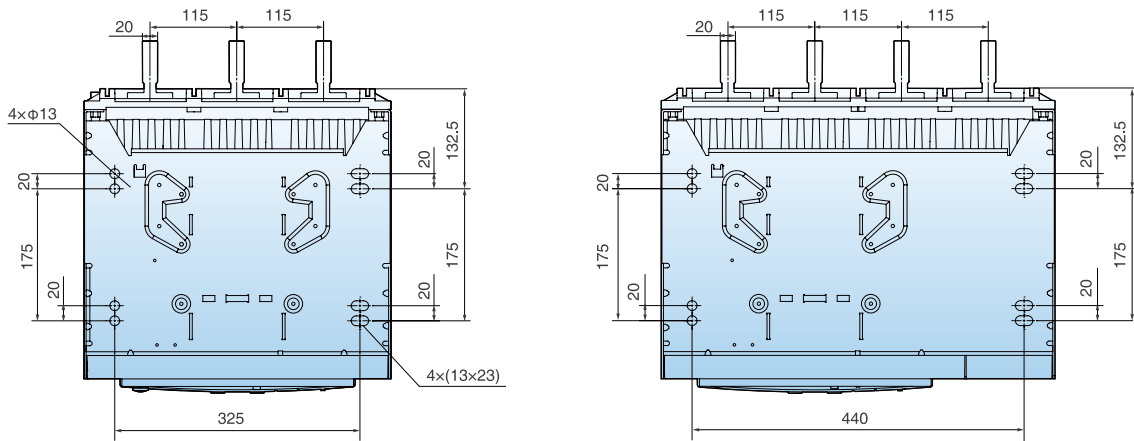

# Size and Connection



## Horizontal Wiring

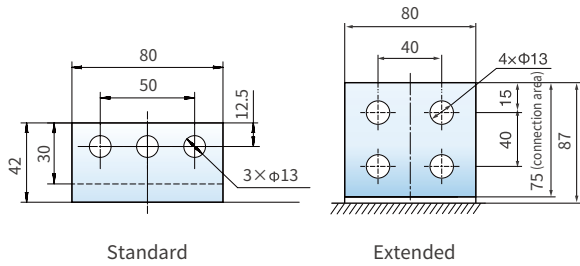
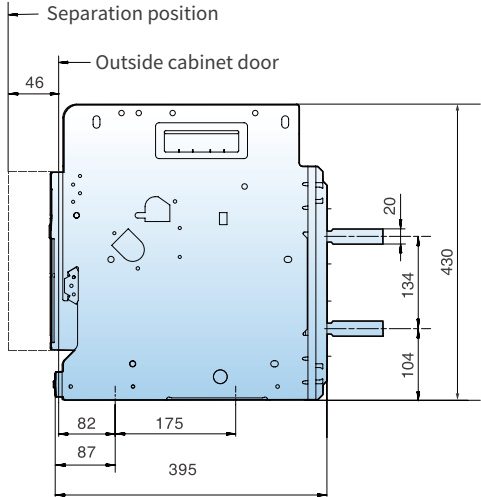
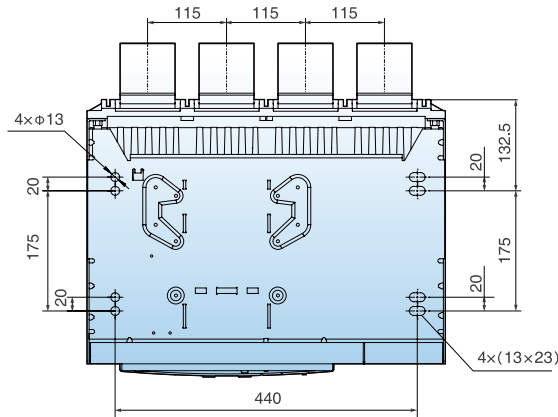
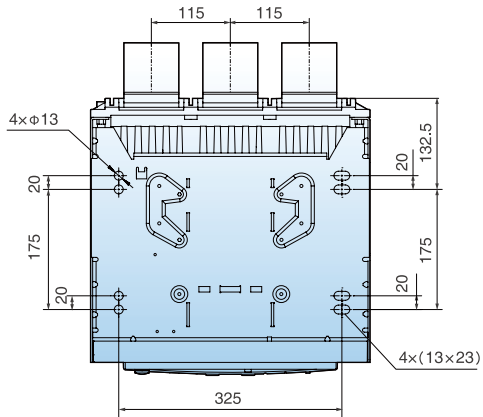

## Cabinet door open hole dimension

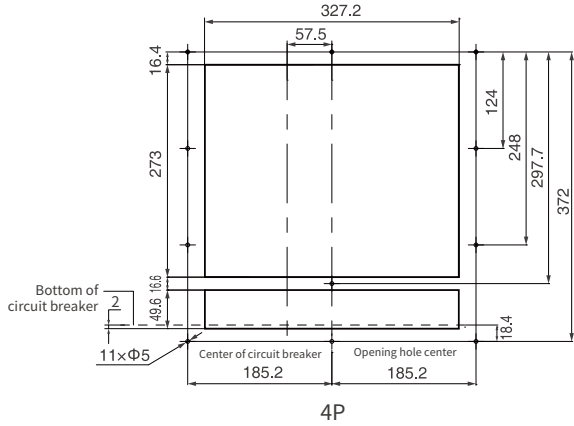
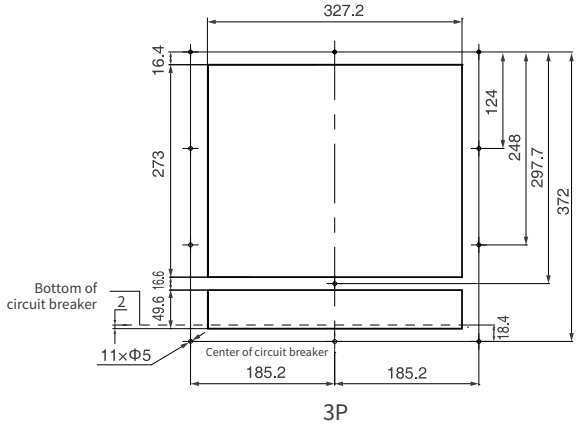

# Size and Connection

## Drawout type (VW3-40H/VW3-40HU/VW3-40HV, 3600~4000A)

### Front view

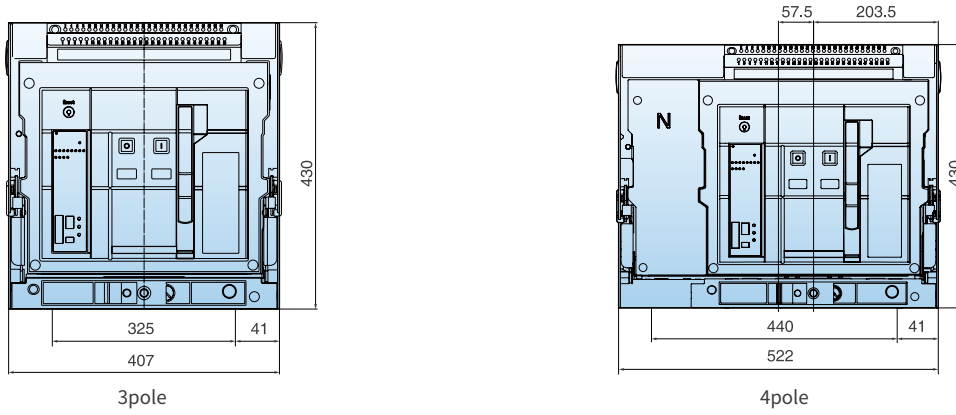

### Vertical Wiring

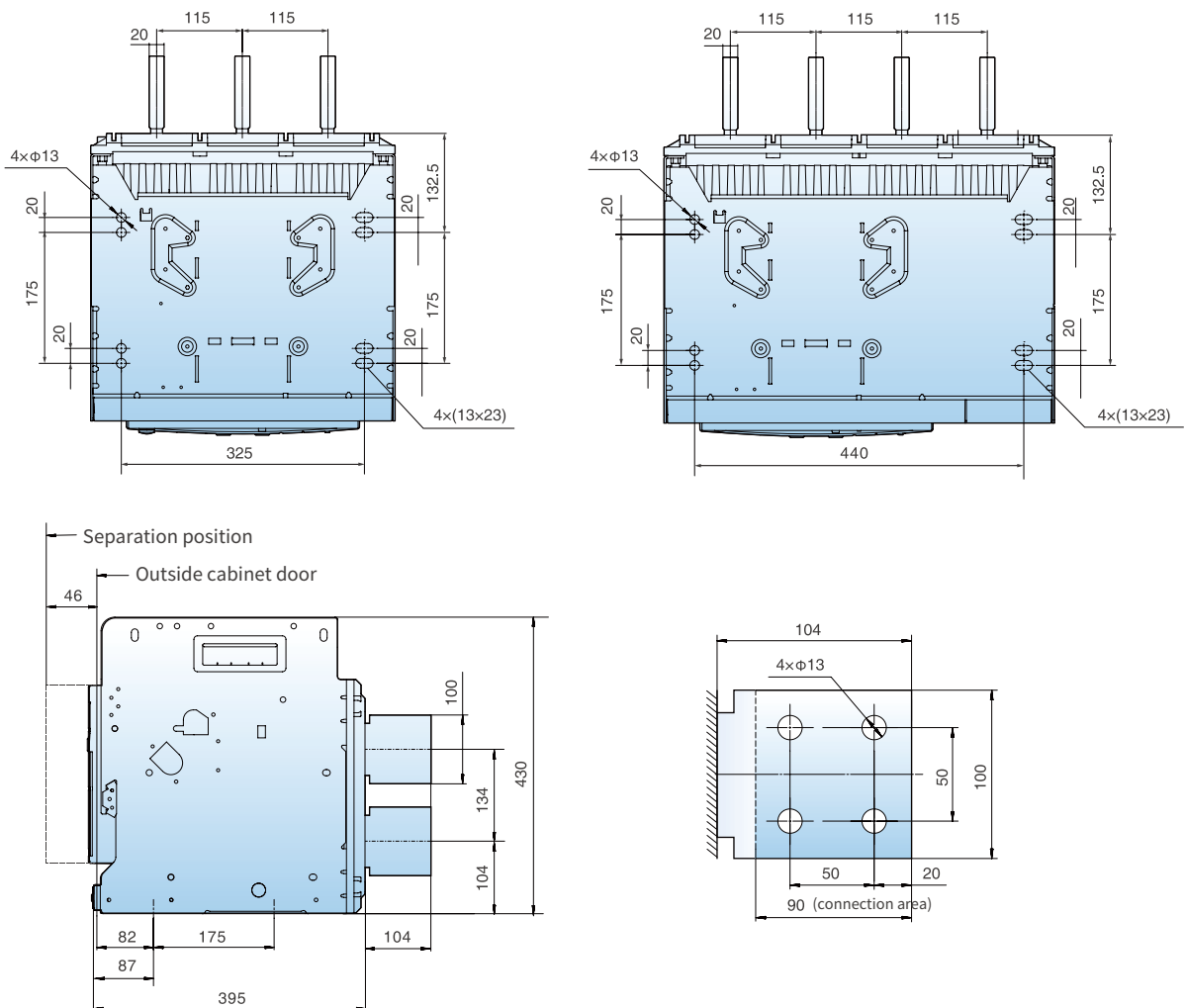

## Horizontal Wiring

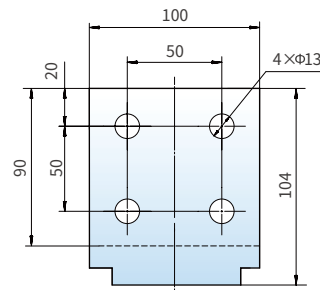
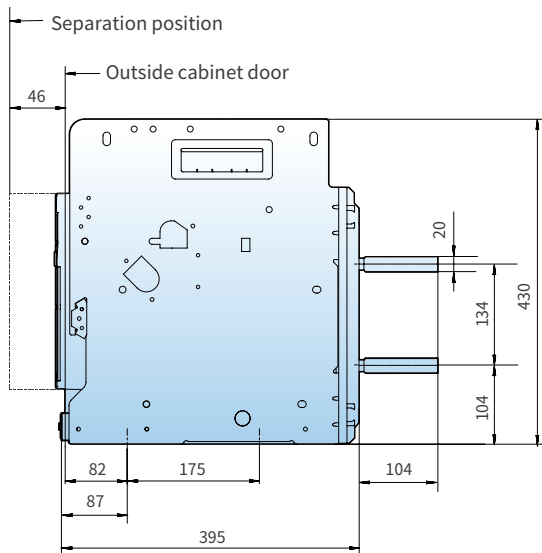
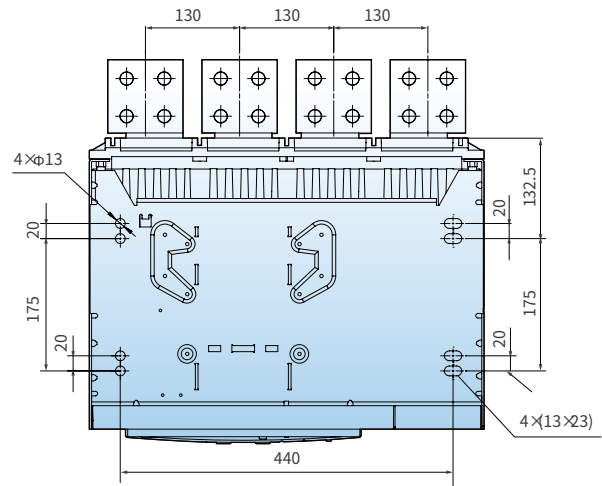
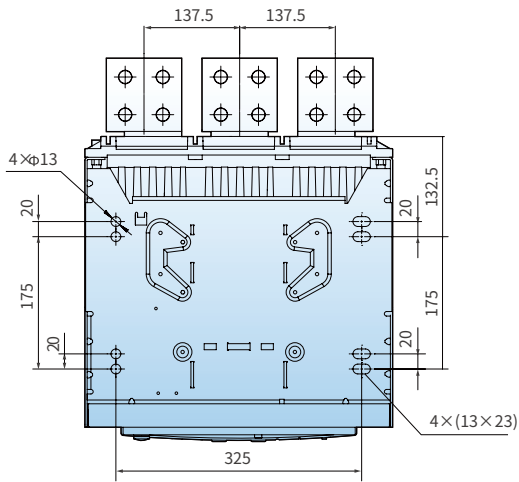

## Cabinet door open hole dimension

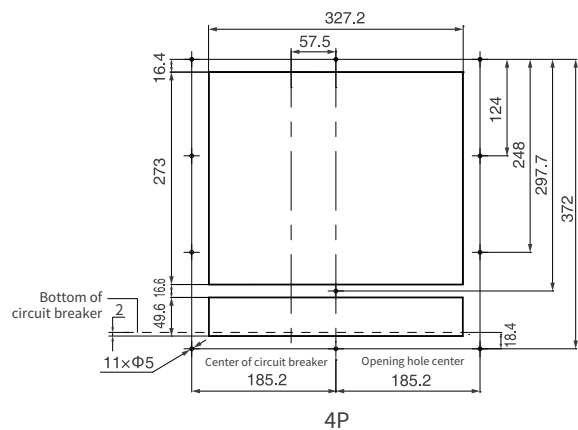
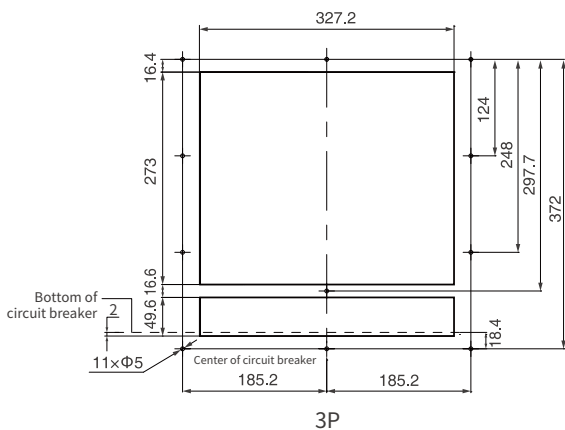

# Size and Connection

## Fixed type (VW3-40H/VW3-40HU/VW3-40HV, 1000~3200A)

### Front view

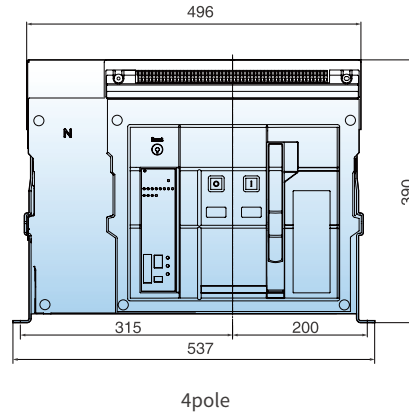
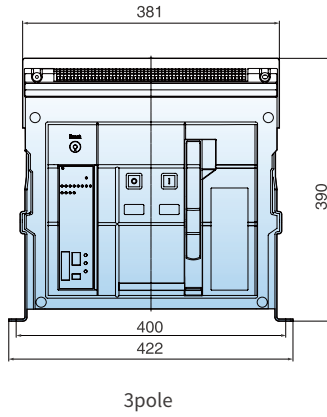

### Vertical Wiring

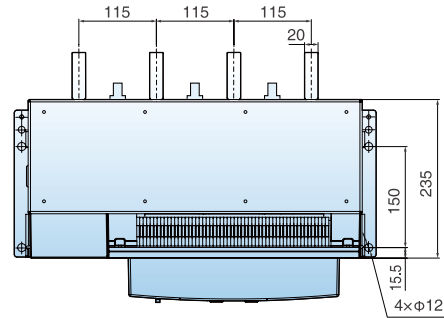
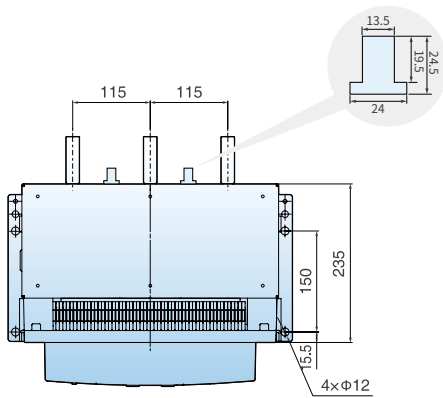

Distance for dismantling the arc extinguishing chamber

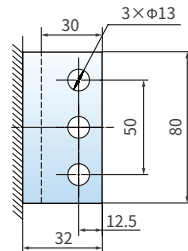
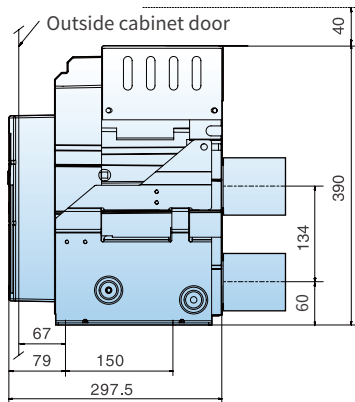

Standard

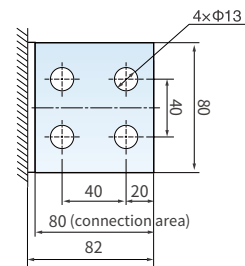

Extended

# Size and Connection



## Horizontal Wiring

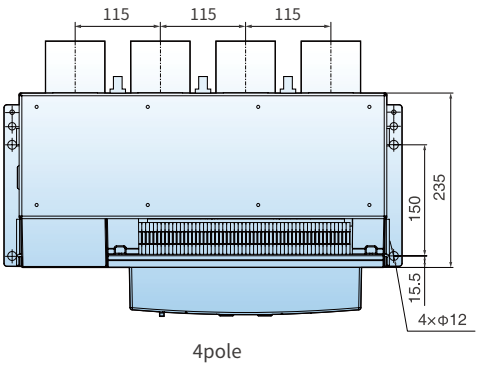
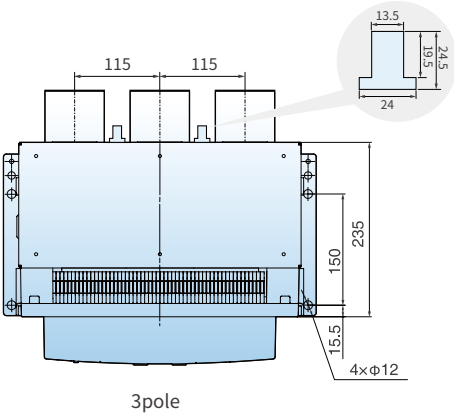

Distance for dismantling the arc extinguishing chamber

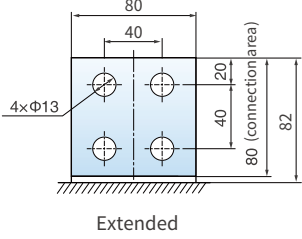
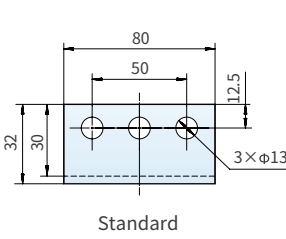
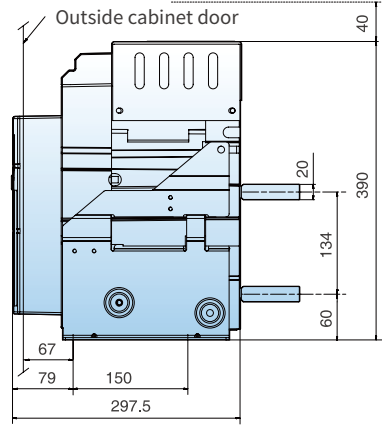

## Cabinet door open hole dimension

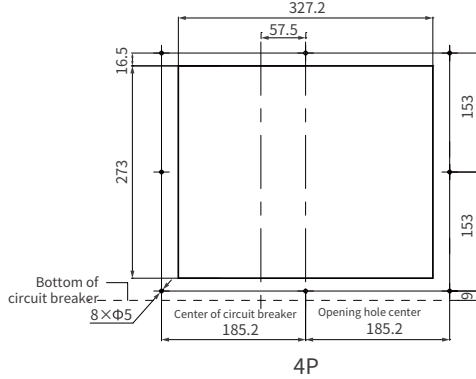
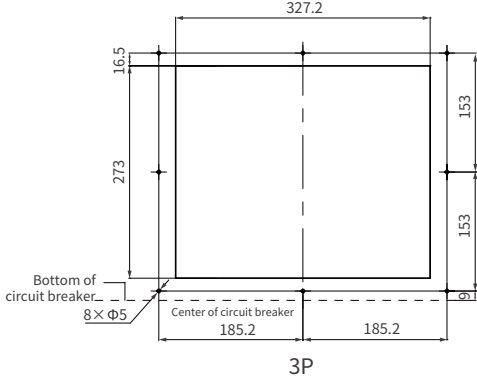

# Size and Connection



## Fixed type (VW3-40H/VW3-40HU/VW3-40HV, 3600~4000A)

### Front view

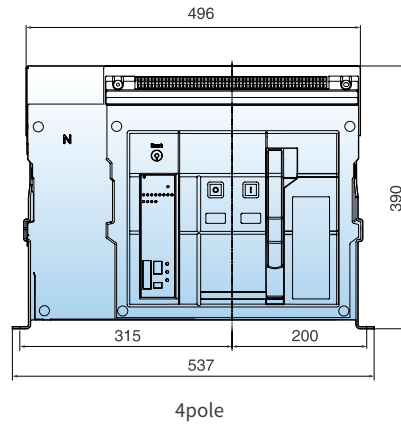
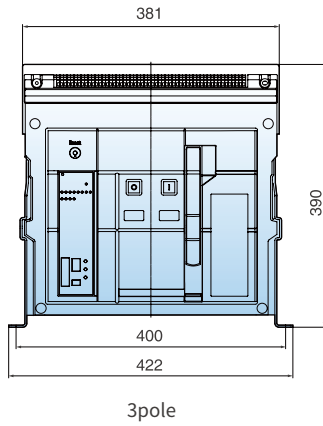

### Vertical Wiring

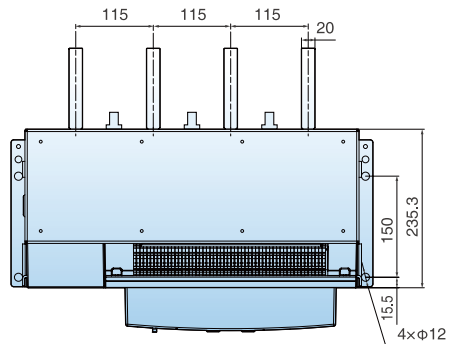
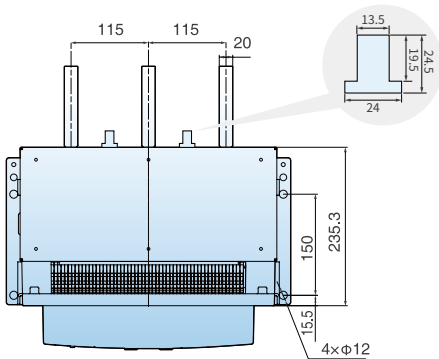

Distance for dismantling the arc extinguishing chamber

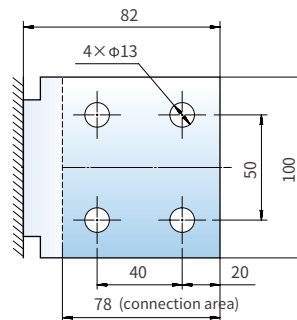
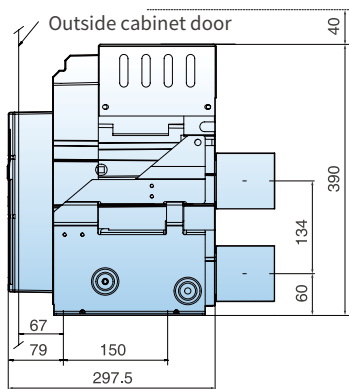

# Size and Connection



## Horizontal Wiring

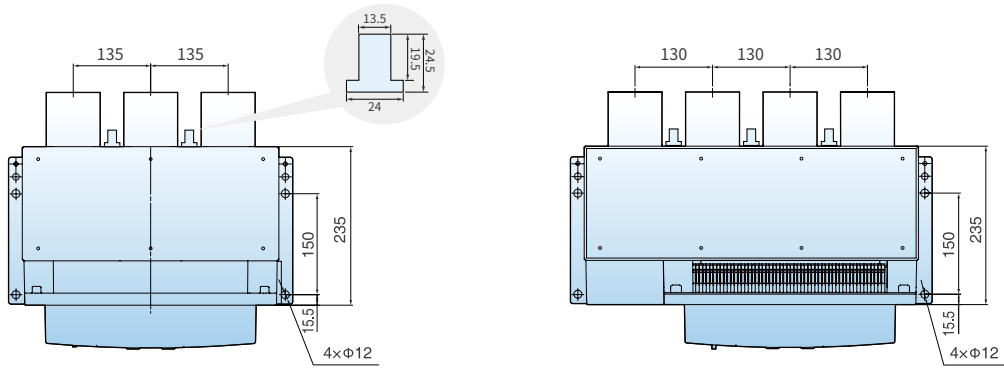

Distance for dismantling the arc extinguishing chamber

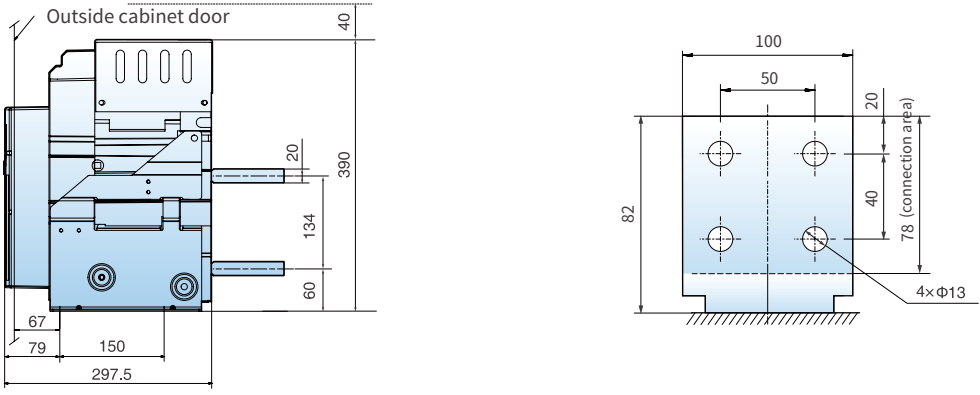

## Cabinet door open hole dimension

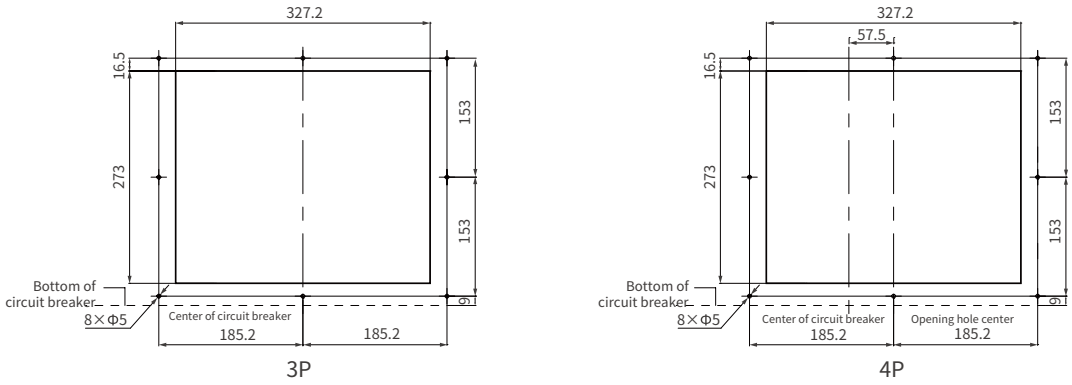

# Size and Connection



## Drawout type (VW3-63H/VW3-63HU/VW3-63HV, 4000~5000A)

Front view

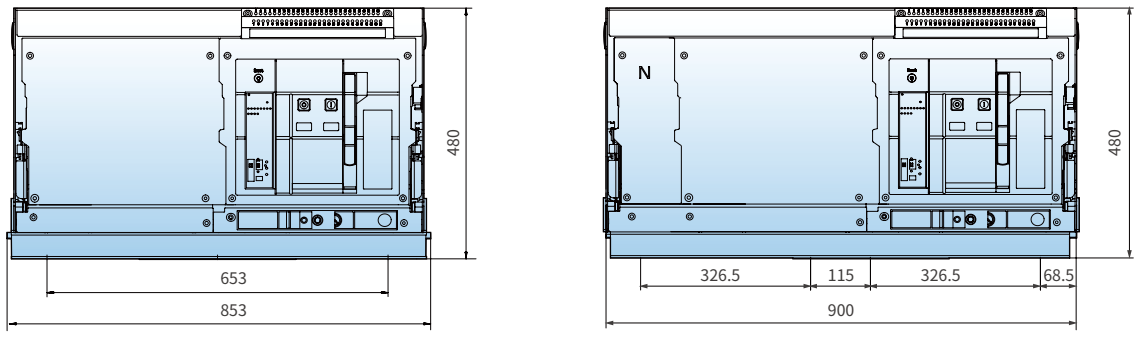

Horizontal Wiring

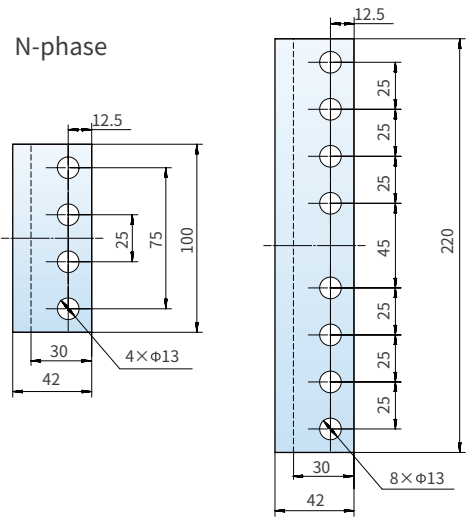
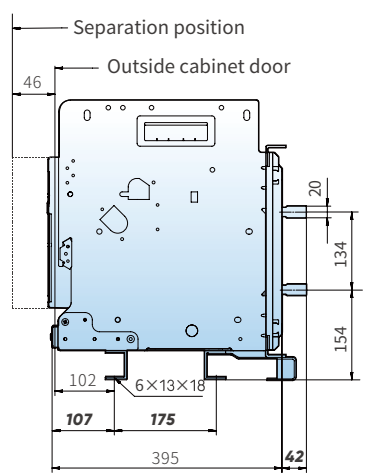
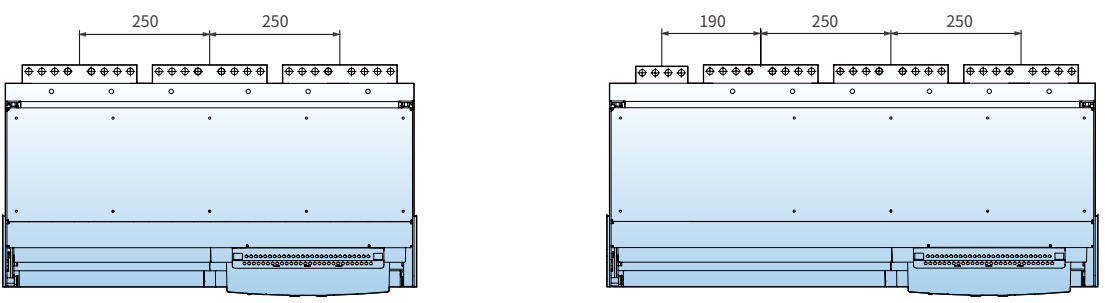

## Drawout type (VW3-63H/VW3-63HU/VW3-63HV, 6300A)

### Front view

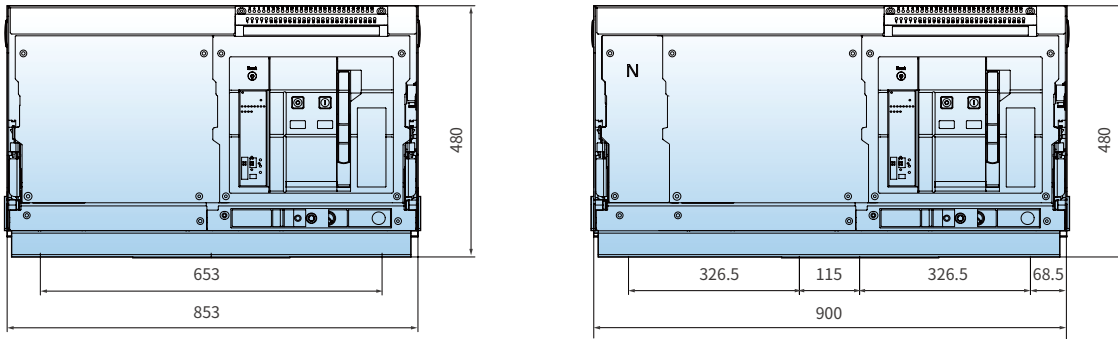

### Horizontal Wiring

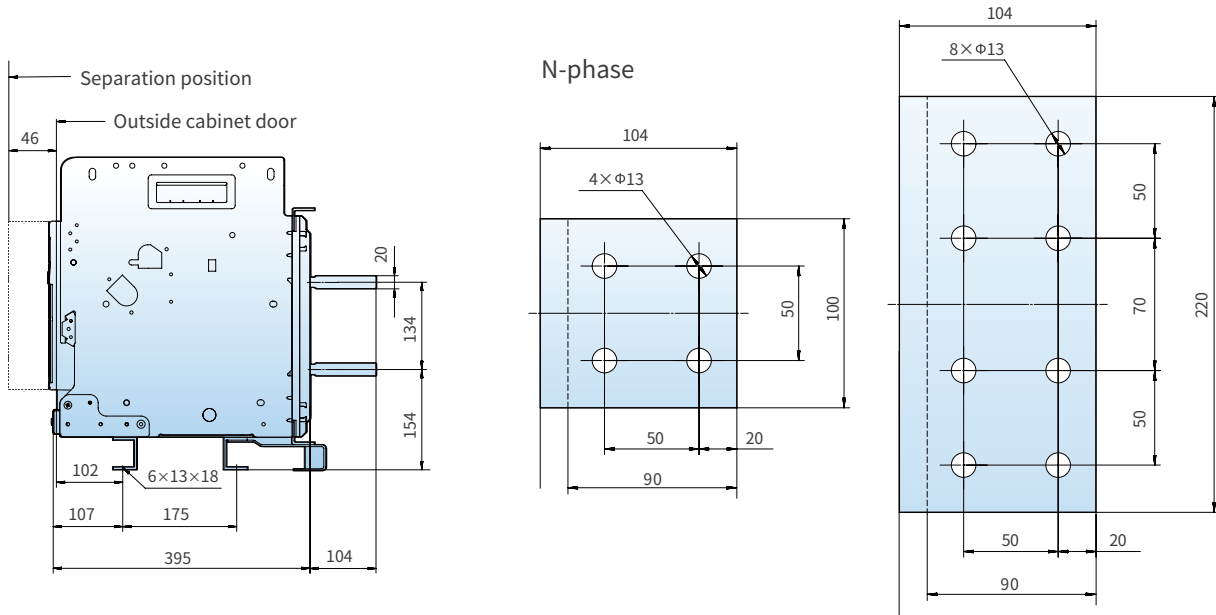
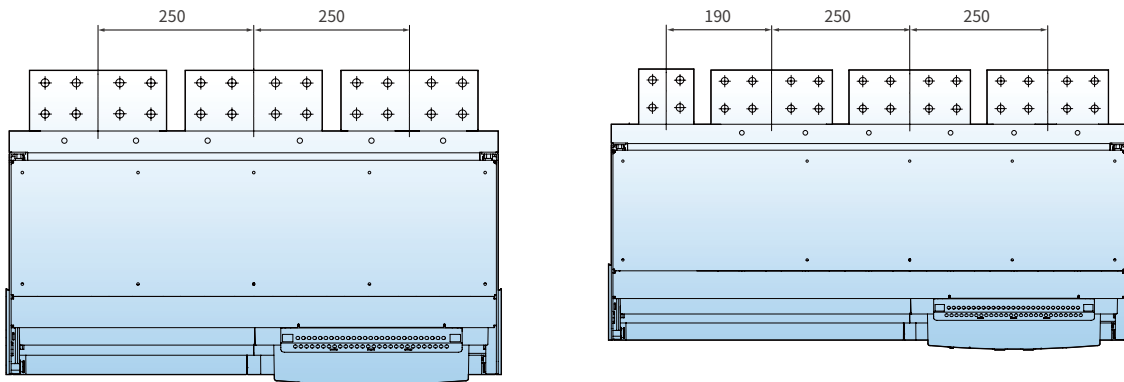

# Size and Connection



## Fixed type (VW3-63H/VW3-63HU/VW3-63HV, 4000~5000A)

### Front view

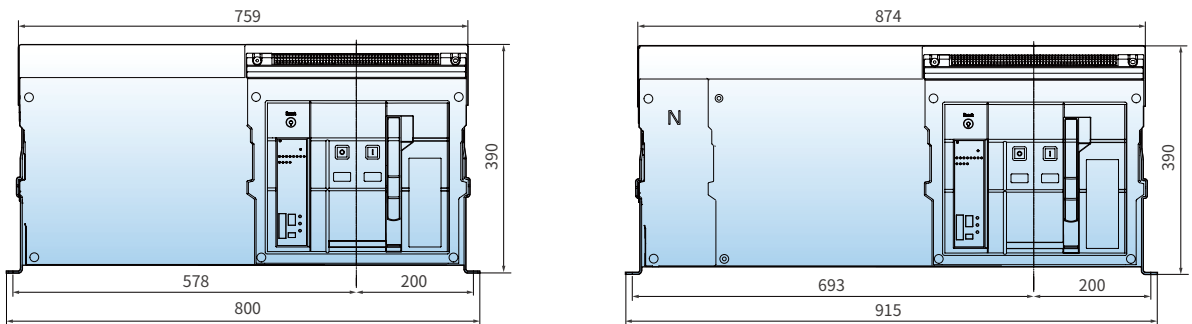

### Horizontal Wiring

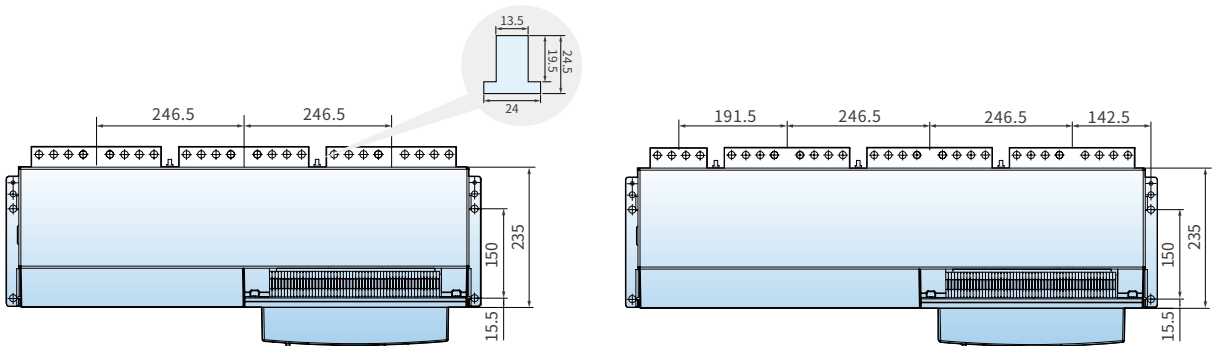

Distance for dismantling the arc extinguishing chamber

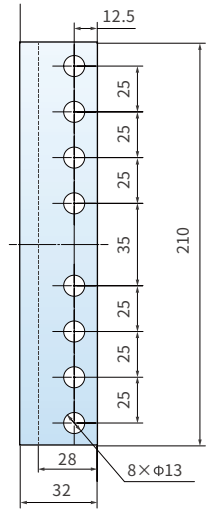
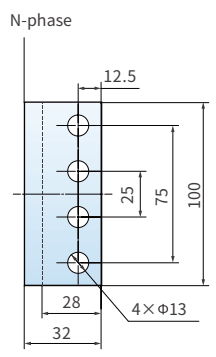
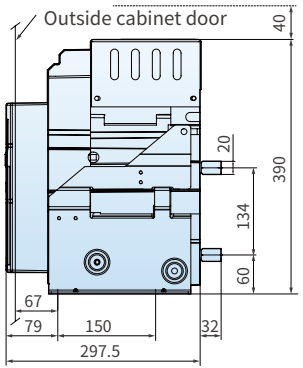

## Fixed type (VW3-63H/VW3-63HU/VW3-63HV, 6300A)

Front view

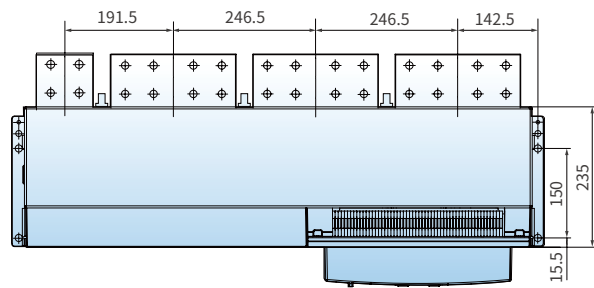
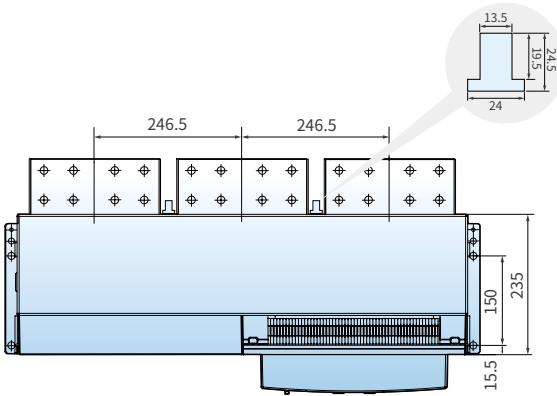
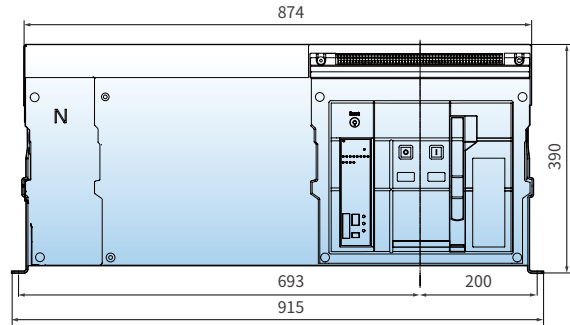
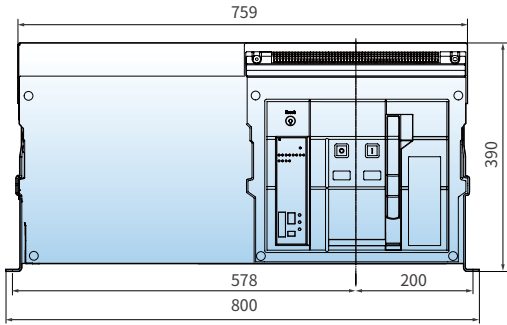

Distance for dismantling the arc extinguishing chamber

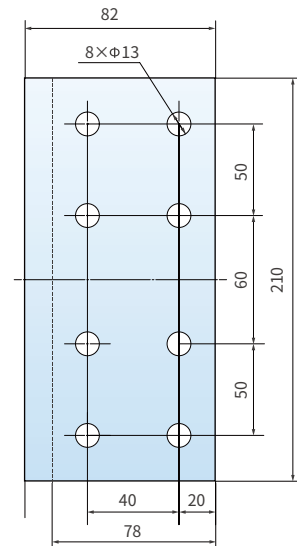
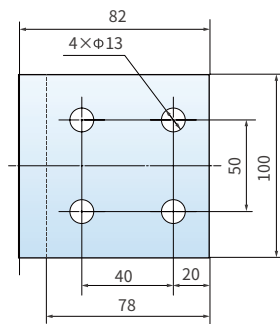
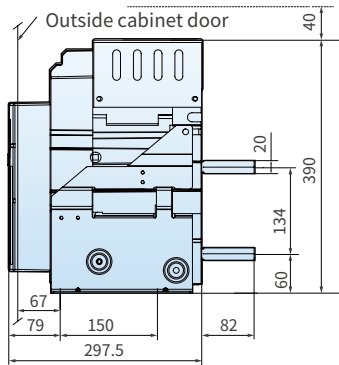

# Size and Connection



## VW3-63H/VW3-63HU/VW3-63HV Cabinet door open hole dimension

### Cabinet door open hole dimension Fixed type

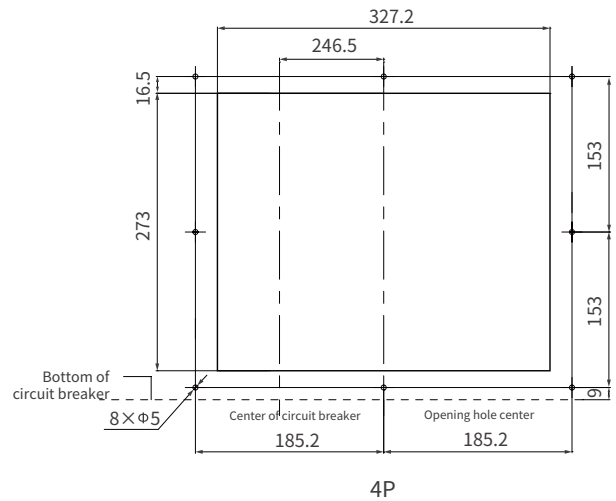
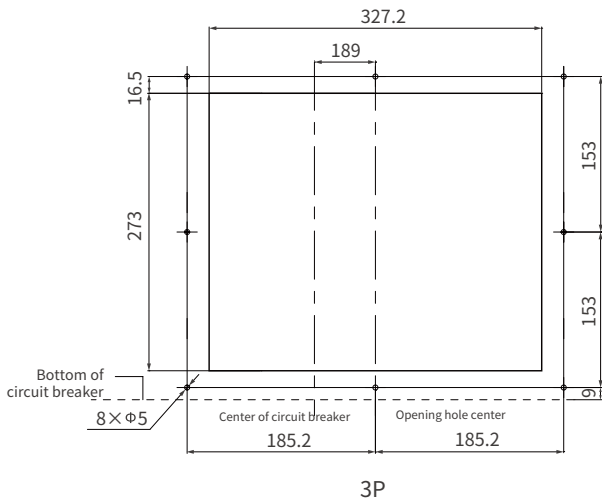

### Cabinet door open hole dimension Drawout type

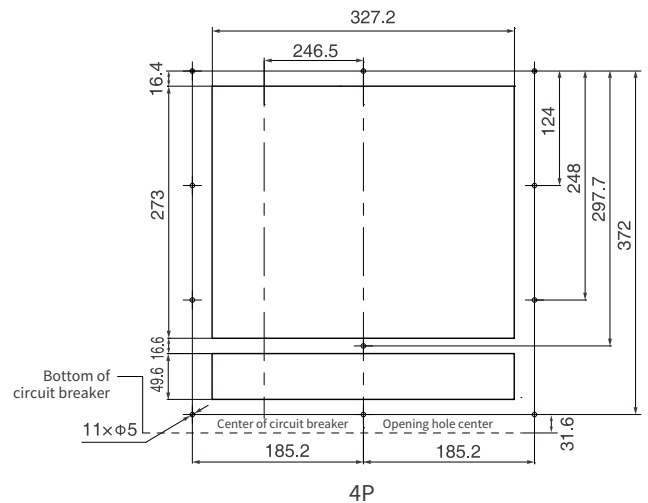
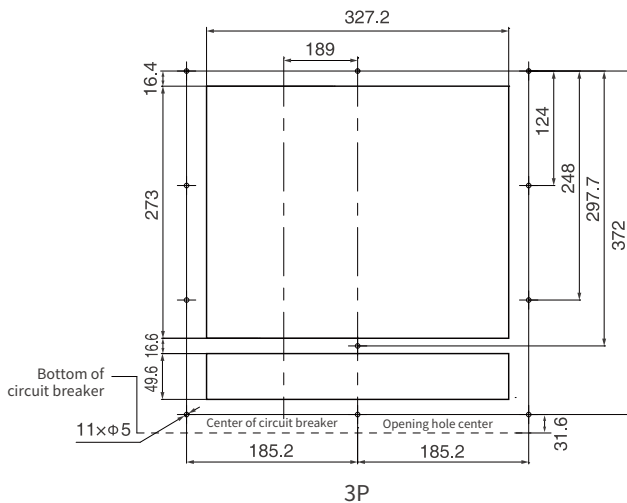

# Size and Connection

When users install the circuit breaker into the cabinet, the safe distance between the circuit breaker and the cabinet is shown in the figure below, and the installation dimensions are shown in the table below.

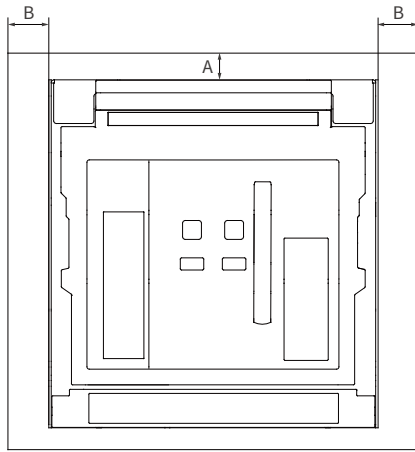

Drawout type circuit breaker

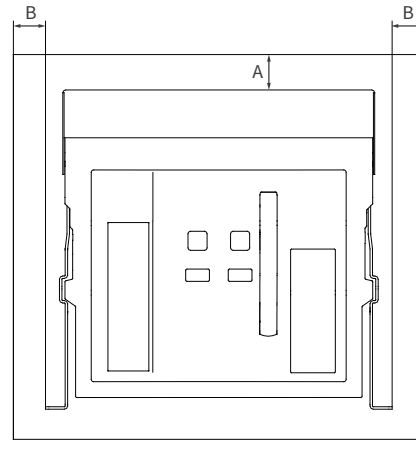

Fixed type circuit breaker

unit: mm

Installation type of the circuit breaker	To the insulator		To the metallic body grounded safely		To the live part	
	A	B	A	B	A	B
Drawout type	0	0	0	0	60	60
Fixed type	0	0	0	0	60	60

**Note:** 1. The safety distance of the fixed circuit breaker should consider the space required to remove the arc extinguishing chamber of 150mm;

Please fill in numbers in \_\_\_\_\_, and check ✓ in

User:			
Number of units ordered:			
Date of ordering:			
Basic parameters	Shell frame level	<input type="checkbox"/> VW3-2000 <input type="checkbox"/> VW3-2500 <input type="checkbox"/> VW3-4000 <input type="checkbox"/> VW3-6300	
	Installation mode	<input type="checkbox"/> F-Fixed type <input type="checkbox"/> D-Drawout type	
	Rated current (A)	VW3-2000	<input type="checkbox"/> 200 <input type="checkbox"/> 400 <input type="checkbox"/> 630 <input type="checkbox"/> 800 <input type="checkbox"/> 1000 <input type="checkbox"/> 1250 <input type="checkbox"/> 1600 <input type="checkbox"/> 2000
		VW3-2500	<input type="checkbox"/> 630 <input type="checkbox"/> 800 <input type="checkbox"/> 1000 <input type="checkbox"/> 1250 <input type="checkbox"/> 1600 <input type="checkbox"/> 2000 <input type="checkbox"/> 2500
		VW3-4000	<input type="checkbox"/> 1000 <input type="checkbox"/> 1250 <input type="checkbox"/> 1600 <input type="checkbox"/> 2000 <input type="checkbox"/> 2500 <input type="checkbox"/> 2900 <input type="checkbox"/> 3200 <input type="checkbox"/> 3600 <input type="checkbox"/> 4000
		VW3-6300	<input type="checkbox"/> 4000 <input type="checkbox"/> 5000 <input type="checkbox"/> 6300
	Breaking type	<input type="checkbox"/> S-standard breaking (AC400/415V) <input type="checkbox"/> S-standard breaking (AC500/550V) <input type="checkbox"/> S-standard breaking (AC660/690V) <input type="checkbox"/> H-high breaking (AC400/415V) <input type="checkbox"/> H-high breaking (AC500/550V) <input type="checkbox"/> H-high breaking (AC660/690V) <input type="checkbox"/> HU-High voltage breaking(AC800V) <input type="checkbox"/> HU-High voltage breaking(AC1140V) <input type="checkbox"/> HV-Ultra high voltage breaking(AC1250V) <input type="checkbox"/> HV-Ultra high voltage breaking(AC1500V) Note: 1. HU-AC1250V only for VW3-4000; 2.S-only for VW3-20	
Number of poles	<input type="checkbox"/> 3-3P <input type="checkbox"/> 4-4P <input type="checkbox"/> 5-3P+N		
Wiring mode	VW3-2000(S/H): <input type="checkbox"/> C11-Standard Horizontal Wiring <input type="checkbox"/> C21-Standard Vertical Wiring C41-Standard Mixed Wiring (Upper Horizontal, Lower Vertical) C51-Standard Mixed Wiring (Upper Vertical, Lower Horizontal) VW3-2500(H/HU/HV): <input type="checkbox"/> C11-Standard Horizontal Wiring <input type="checkbox"/> C12-Extended Horizontal Wiring VW3-4000(H, 1000-3200A): <input type="checkbox"/> C11-Standard Horizontal Wiring <input type="checkbox"/> C12-Extended Horizontal Wiring <input type="checkbox"/> C21-Standard Vertical Wiring <input type="checkbox"/> C22-Extended Vertical Wiring <input type="checkbox"/> C31-Standard Forward Wiring <input type="checkbox"/> C41-Standard Mixed Wiring (Upper Horizontal, Lower Vertical) <input type="checkbox"/> C42-Extended Mixed Wiring (Upper Horizontal, Lower Vertical) <input type="checkbox"/> C51-Standard Mixed Wiring (Upper Vertical, Lower Horizontal) <input type="checkbox"/> C52-Extended Mixed Wiring (Upper Vertical, Lower Horizontal) <input type="checkbox"/> C61-Standard Mixed Wiring (Upper Forward, Lower Horizontal) <input type="checkbox"/> C71-Standard Mixed Wiring (Upper Horizontal, Lower Forward) <input type="checkbox"/> C81-Standard Mixed Wiring (Upper Vertical, Lower Forward) <input type="checkbox"/> C91-Standard Mixed Wiring (Upper Forward, Lower Vertical) VW3-4000(HU/HV, 1000-3200A): <input type="checkbox"/> C11-Standard Horizontal Wiring <input type="checkbox"/> C12-Extended Horizontal Wiring <input type="checkbox"/> C21-Standard Vertical Wiring VW3-4000(H/HU/HV, 3600-4000A): <input type="checkbox"/> C12-Extended Horizontal Wiring <input type="checkbox"/> C22-Extended Vertical Wiring VW3-6300(H/HU/HV, 4000-5000A): <input type="checkbox"/> C11-Standard Horizontal Wiring VW3-6300(H/HU/HV, 6300A): <input type="checkbox"/> C12-Extended Horizontal Wiring		
Controller parameters	Controller model	<input type="checkbox"/> VWC2 (DIP switch) <input type="checkbox"/> VWC4 (digital screen) <input type="checkbox"/> VWC6 (LCD) Note: VWC2 is only used for VW3-20	
	Protection type	<input type="checkbox"/> Conventional type (standard configuration) <input type="checkbox"/> V-Voltage measurement and protection type <input type="checkbox"/> P-Harmonic measurement and protection type	
	Communication function	<input type="checkbox"/> H-Modbus protocol <input type="checkbox"/> MP-Profibus-DP protocol <input type="checkbox"/> MD-Devicenet protocol Note: Only VWC6 have communication function	
	Signal unit	<input type="checkbox"/> S1-4DO <input type="checkbox"/> S2-3DO+1DI <input type="checkbox"/> S3-2DO+2DI Note: VWC4 only S1-4DO	
	Remote reset	<input type="checkbox"/> Z2-AC230V    Note: VWC2 does not have remote reset function	
	External transformer	3P+N required: <input type="checkbox"/> N1 <input type="checkbox"/> N2 <input type="checkbox"/> N3 <input type="checkbox"/> N4 <input type="checkbox"/> E	
	Grounding mode	<input type="checkbox"/> T(default) <input type="checkbox"/> W <input type="checkbox"/> E	
Contact wear equivalent	<input type="checkbox"/> J		
Required accessories	Electric operating mechanism	<input type="checkbox"/> D1-AC400V <input type="checkbox"/> D2-AC230V/DC220V <input type="checkbox"/> D4-AC/DC110V <input type="checkbox"/> D5-DC24V	

# Order Notes

# VOZWEI

Required accessories	Shunt release	<input type="checkbox"/> F1-AC400V <input type="checkbox"/> F2-AC230V/DC220V <input type="checkbox"/> F4-AC/DC110V <input type="checkbox"/> F5-DC24V	
	Closed electromagnet	<input type="checkbox"/> B1-AC400V <input type="checkbox"/> B2-AC230V/DC220V <input type="checkbox"/> B4-AC/DC110V <input type="checkbox"/> B5-DC24V	
Optional accessories	Under-voltage release	Voltage specifications	<input type="checkbox"/> Q1-AC400V <input type="checkbox"/> Q2-AC230V <input type="checkbox"/> Q5-DC24V
		Delay time	<input type="checkbox"/> 0-Instantaneous <input type="checkbox"/> 1-1s delay <input type="checkbox"/> 3-3s delay <input type="checkbox"/> 5-5s delay
	Loss of voltage release	Voltage specifications	<input type="checkbox"/> S1-AC400V <input type="checkbox"/> S2-AC230V
		Delay time	<input type="checkbox"/> 0-Instantaneous <input type="checkbox"/> 1-1s delay <input type="checkbox"/> 3-3s delay <input type="checkbox"/> 5-5s delay
	Voltage-check closing device	<input type="checkbox"/> J1-AC400V <input type="checkbox"/> J2-AC230V	
	Auxiliary contact	<input type="checkbox"/> A33-3NO3NC <input type="checkbox"/> A44-4NO4NC <input type="checkbox"/> A55-5NO5NC <input type="checkbox"/> A66-6NO6NC <input type="checkbox"/> ____NO____NC (Max. 14)	
		<input type="checkbox"/> A3-Three-group switching <input type="checkbox"/> A4-Four-group switching <input type="checkbox"/> A5-Five-group switching <input type="checkbox"/> A6-Six-group switching <input type="checkbox"/> ____-group switching (Max. 14)	
	Closing ready	<input type="checkbox"/> BX-Closing ready signal output unit	
	Counter	<input type="checkbox"/> JS-Counter	
	Drawer seat door interlock	<input type="checkbox"/> CM1-Drawout type (with the right side of the door interlock)	
	Door frame	<input type="checkbox"/> M-Door frame Note: standard	
	Position indicator	<input type="checkbox"/> CX-Drawer seat three-position signal output	
	Relay module	<input type="checkbox"/> R-Relay module	
	Power supply	<input type="checkbox"/> AC65~500V, DC80~700V    Note: standard	
Button lock	<input type="checkbox"/> S-Button lock		
Voltage conversion module	<input type="checkbox"/> P2-Voltage conversion module		
Language type		<input type="checkbox"/> Chinese <input type="checkbox"/> Y-English	
Interlocking accessories	Off-position lock	<input type="checkbox"/> SF11-Key lock device (one lock and one key) <input type="checkbox"/> SF21-Key lock device (two locks and one key) <input type="checkbox"/> SF31-Key lock device (three locks and one key) <input type="checkbox"/> SF32-Key lock device (three locks and two keys) <input type="checkbox"/> SF53-Key lock device (five locks and three keys)	
		Mechanical interlocking	Cable type
	Hard rod type		<input type="checkbox"/> SY11-Mechanical interlocking device (two sets of hard rods, one for closing and one for opening)
Special requirements	Overload and long-time delay current $I_r=$ ___ A		Overload and long-time delay time $t_r=$ ___ s
	Short-circuit short-time delay current $I_{sd}=$ ___ A		Short-circuit short-time delay time $t_{sd}=$ ___ s
	Short circuit instantaneous current $I_i=$ ___ A		
	Grounding fault current $I_g=$ ___ A		Grounding fault time $t_g=$ ___ s
	Current imbalance percentage $\delta=$ ___ %		Current imbalance action time $\delta=$ ___ s
	Current leakage setting value $I_{\Delta n}$ ___ A		Current leakage action time $t_{\Delta n}$ ___ s
	Load monitoring1 current setting value $I_{c1}$ ___ A		Inverse time-limit time $t_{c1}$ ___ s
Load monitoring2 current setting value $I_{c2}$ ___ A		Fixed time-limit $t_{c2}$ ___ s	
Other requirements			

# VW3GZ

DC Disconnect





- Tailored for solar energy and energy storage systems
- Rated working voltage DC500~1500V
- With high breaking capacity up to 100kA
- Multiple patented arc-extinguishing designs ensure
- lower temperature rise

## Ambient conditions

---

### Operating ambient temperature/storage temperature

- Recommended ambient air temperature limit is -40°C~+70°C, it can reach to +70°C in a short time (within 24h), derating is required above 40°C

### Altitude conditions

- The altitude of the installation location is less than 5000m.
- Relative humidity: not exceed 50% at the maximum ambient temperature of +40°C, but higher relative humidity at the lower temperature, for example, 90% at 20°C. Special measures should be taken considering the dew on product surface due to temperature change.

### Pollution grade

- Level 3

### Salt spray grade

- GB2423.18 - Extreme Grade 2
-

Series		VW3GZ-16		VW3GZ-40
				
Rated current In(A)		200, 400, 630, 800, 1000, 1250, 1600		630, 800, 1000, 1250, 1600, 2000, 2500, 2900, 3200, 3600, 4000
Rated working voltage Ue(V)50Hz/60Hz		DC1000	DC1500	DC500/750/1000/1200/1500
Rated insulation voltage Ui(V)		1600		1600
Rated impulse withstand voltage Uimp(kV)		12		15
Number of poles		3P	4P	2P
Rated short circuit making capacity (peak value)Icm(kA)		55		100
Rated short-time withstand current (effective value) Icw(kA) 1s		55		100kA 1s 150kA 0.2s
Electrical life (times)		500	500	1000
Operating performance	Mechanical life (times)	Without maintenance		10000
		Maintenance		10000
Operational condition	Utilization category		DC22/23A	DC-PV2
	Pollution degree		3	3
	Protection grade		IP30	IP40
	Ambient temperature		-40~75°C	≥-40°C
	Altitude		≤5000m	≤5000m
Outline dimension(mm)		Fixed type 2p		395 x 318.5 x 321
(H x W x D)		Fixed type 3p		/
		Fixed type 4p		/

**Note:** Derating is required when the temperature of VW3Z-40 exceeds 40°C.  
Refer to the temperature derating table for specific requirements."

## Model Explanation and Encoding Rules

SN	Name	Specification, type code	Description
1	Design code	VW3GZ:Design code	/
2	Frame rating	16: 1600A; 40: 4000A	/
3	Breaking type	Empty:Standard breaking level	/
4	Rated current	VW3GZ-16: 02: 200A; 04: 400A; 06: 630A; 08: 800A; 10: 1000A; 12: 1250A; 16: 1600A VW3GZ-40: 06: 630A; 08: 800A; 10: 1000A; 12: 1250A; 16: 1600A; 20: 2000A; 25: 2500A; 29: 2900A; 32: 3200A; 36: 3600A; 40: 4000A	/
5	Installation mode	F: Fixed type	/
6	Number of poles	2: 2P; 3: 3P; 4: 4P Note: (2P only for VW3GZ-40)	/
7	Electric energy storage mechanism	D1: AC400V; D2: AC230V/DC220V; D4: AC/DC110V; D5: DC24V	/
8	Shunt release	F1: AC400V; F2: AC230V/DC220V; F4: AC/DC110V; F5: DC24V	/
9	Closed electromagnet	B1: AC400V; B2: AC230V/DC220V; B4: AC/DC110V; B5: DC24V	/
10	Under-voltage release / Loss of voltage release	Under-voltage release      Q1: AC400V; Q2: AC230V; Q5: DC24V	1.Choose one from the Under-voltage release, Loss of voltage release;
		Loss of voltage release      S1: AC400V; S2: AC230V	
11	Under-voltage release / loss of voltage release Delay time	0: Instantaneous; 1: 1s delay; 3: 3s delay; 5: 5s delay	/
12	Auxiliary contact	A33: 3NO3NC; A44: 4NO4NC; ... ; A1414: 14NO14C	/
		A3: Three-group switching; A4: Four-group switching; ...; A14: Fourteen-group switching	/
13	Internal Accessories	BX: Closing ready signal output unit JS: Counter functional unit Note: JS only for VW3GZ-40	/
14	External accessories	M: Doorframe Note: M only for VW3GZ-16, standard S: Button lock	/
15	Wiring mode	C1: Horizontal wiring; C2: Vertical wiring; C4: Mixed wiring(upper horizontal,lower vertical); C5: Mixed wiring(upper vertical,lower horizontal); Note: C4, C5 only for VW3GZ-40	/
		1: Standard wiring	/
16	Language type	Empty: Chinese; Y: English	/

Interlocking Piece Model Explanation and Encoding Rules

<p>Key lock (16, 40)</p>	<p>SF11: Key lock device (one lock and one key)                  SF21: Key lock device(two locks and one key)                  SF22: Key lock device(two locks and two keys)                  SF31: Key lock device(three locks and one key)                  SF32: Key lock device (three locks and two keys)                  SF53: Key lock device(five locks and three keys)</p>	<p>Select one from six locks;</p>
<p>Mechanical interlocking</p>	<p>SR11: Mechanical interlocking device                  (two sets of steel cables,one for closing and one for opening)</p> <p>SR12: Mechanical interlocking device                  (three sets of steel cables,one for closing and two for opening)</p> <p>SR21: Mechanical interlocking device                  (three sets of steel cables,two for closing and one for opening)</p> <p>SY11: Mechanical interlocking device                  (two sets of hard rods,one for closing and one for opening)</p>	<p>1.Select one from five mechanical interlocks</p>

## Shunt Release(F)

To break the DC disconnect by remote control

project	VW3GZ-16	VW3GZ-40
---------	----------	----------



Rated insulation voltage(Ui)	Rated control supply voltage(Us)	Closed current	Instantaneous power	Rated control supply voltage(Us)	Closed current	Instantaneous power
		VW3GZ-16	VW3GZ-16		VW3GZ-40	VW3GZ-40
400V	AC380V/AC400V	1.5A	600W	AC230V	2.9A	575VA
	AC220V/AC230V	2.2A	500W	AC400V	2.1A	780VA
	DC220V	2.2A	500W	DC110V	5.2A	550W
	DC110V	2.5A	270W	DC220V	2.9A	630W
	DC24V	2.5A	60W	DC24V	11A	264W
	/			AC110V	5.2A	550VA
Operating voltage	(70%-10%)Us					
Action time(ms) Switching resposetime in Us	<50ms					

## Auxiliary contact

project	VW3GZ-16	VW3GZ-40
---------	----------	----------

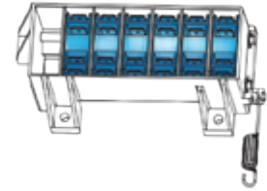

Rated insulation voltage(U)					400V
Conventional Thermal Current (Ith)					16A
Utilization Category	AC-12	AC-15	DC-12	DC-13	AC-12 AC-15 DC-12
Rated working voltage(Ue)	AC380	AC400	DC250	DC220 DC48	AC380 AC400 DC250
Rated Operating Current(Ie)	16A	3A	5A	1.2A 6A	16A 3A 5A

Type	Code	Type	Code
3NO3NC	A33	4NO4NC	A44
5NO5NC	A55	6NO6NC	A66
7NO7NC	A77	8NO8NC	A88
9NO9NC	A99	10NO10NC	A1010
11NO11NC	A1111	12NO12NC	A1212
13NO13NC	A1313	14NO14NC	A1414

**Note:**

- VW3GZ-16 series have 3NO 3NC~14NO 14NCNO:normally open contactNC:normally closed contact
- VW3GZ-40 series only have 3NO 3NC~6NO 6NCNO,"N6"indicates contacts with no common point,while "N6"denotes contacts with a common point The same logic applies to other codes
- Standard configuration includes N3/N33 contact arrangements
- The auxiliary contacts support a minimum load of DC24V 10mA

## Undervoltage (loss-of-voltage) release (Q)

Rated operational voltage(V)		VW3GZ-16				VW3GZ-40			
		Undervoltage release		Loss-of-voltage release		Undervoltage release		Loss-of-voltage release	
		AC230	AC400	AC230	AC400	AC230	AC230	AC230	AC400
Action type	Type	Code							
	Instantaneous time	Q20	Q10	S20	S10	Q20	Q10	S20	S10
	Delay time 1s	Q21	Q11	S21	S11	Q21	Q11	S21	S11
	Delay time 3s	Q23	Q13	S23	S13	Q23	Q13	S23	S13
	Delay time 5s	Q25	Q15	S25	S15	Q25	Q15	S25	S15
Operation voltage(V)		(0.35-0.7)Ue		<0.35Ue		(0.35-0.7)Ue		(0.1-0.35)Ue	
Guarantee the reliable closing		(0.85-1.1)Ue							
Not guarantee the reliable		≤0.35Ue							
Maintain power consumption(W)		4	3.27	3.5	3.3	3.4	3.6	3.24	6.36

## Accessories for VW3GZ-16: Motor operating mechanism (D)

The DC disconnect has the function of motor driven energy storage and automatic energy restoring.  
(Manual energy storage can also be done)



Rated control supply voltage $U_s$ (V)	AC230	AC400	DC110	DC220	DC24
Operation voltage	(85%-110%) $U_s$				
Operating power	80VA		80W		
Starting power	400VA		400W		
Energy storage time(s)	$\leq 5$				
Motor type	Brush motor				

## Closed Electromagnet (B)

After storing energy, closed electromagnet may make the energy release instantly so that the DC disconnect is closed quickly.



Power Consumption Table of Closed Electromagnet

Rated insulation voltage ( $U_i$ )	Rated control supply voltage ( $U_s$ )	Closed current	Instantaneous power
		VW3GZ-16	VW3GZ-16
400V	AC380V/AC400V	1.5A	600W
	AC220V/AC230V	2.2A	500W
	DC220V	2.2A	500W
	DC110V	2.5A	270W
	DC24V	2.5A	60W
Operating voltage	(85%-110%) $U_s$		
Minimum time of power on	100ms $\pm$ 10ms		
Action time (ms) Switching response time in $U_s$	<50ms		

## Lock

### Off-position key lock (SF11, SF21, SF31, SF32, SF53, SF22)



Opening position lock can lock the OFF button of the switch disconnecter on the pressed position. After the opening position lock is chosen by the users, we would install and configurate.

#### Application method:

One lock one key (SF11): One DC disconnecter with one same lock and one key, and only allowed to closed when locked.

Two locks one key (SF21): Two DC disconnecters with two same locks and one key, and only allowed one DC disconnecter closed.

Three locks one key (SF31): Three DC disconnecters with three same locks and one key, and only allowed one DC disconnecter closed.

Three locks two keys (SF32): Three DC disconnecters with three same locks and two keys, and only allowed two DC disconnecters closed.

Five locks three keys (SF53): Five DC disconnecters with five same locks and three keys, and only allowed three DC disconnecters closed.

Double interlock (SF22): With two different sets of keys and locks.

## Phase separator

Phase separators are vertically installed between wiring boards of DC disconnecter which strengthen insulation.



## Accessories for VW3GZ-40: Motor operating mechanism (D)



The circuit breaker's spring charging is accomplished by a motor-operated mechanism, featuring both motor-powered energy storage and automatic recharging functions (manual charging is also available). It has no overvoltage protection capability. The device can withstand 1.4Us for 1 second, but prolonged energization may cause burnout. The mechanism can operate 100 cycles at 1.4Us with a maximum frequency of once every 3 minutes.

project	Parameters					
Rated control voltageUs	AC230	AC400	DC110	DC220	DC24	AC110
Operational voltage	(0.85-1.1) Us					
Operating power	150W					
Starting power	500-600W					
Energy storage time (s)	≤5s					
Type	Brushed Motor					

## Closed electromagnet (B)



The closing solenoid is primarily composed of a coil, iron core assembly, and electronic components. When energy storage is completed and the closing operation is ready, energizing the closing solenoid enables instantaneous release of the stored energy in the operating mechanism, causing rapid closure of the circuit breaker. The shunt trip device has no overvoltage protection function. It can withstand 1.4 times the rated control supply voltage (1.4Us) for 1 second. Prolonged energization may cause burnout. The device is capable of 100 operations at 1.4Us with a maximum operating frequency of one operation per 3 minutes.

Rated Insulation Voltage (Ui)	VW3GZ-40		
	(Us)	Pickup Inrush Current	Pickup Inrush Power
400V	AC230V	2.9A	575VA
	AC400V	2.1A	780VA
	DC110V	5.2A	550W
	DC220V	2.9A	630W
	DC24V	11A	264W
	AC110V	5.2A	550VA
Operating Voltage	(0.85-1.1)Un		
Movement time (ms)	<50ms		

## Lock

### Off-position key lock (SF11, SF21, SF31, SF32, SF53, SF22)

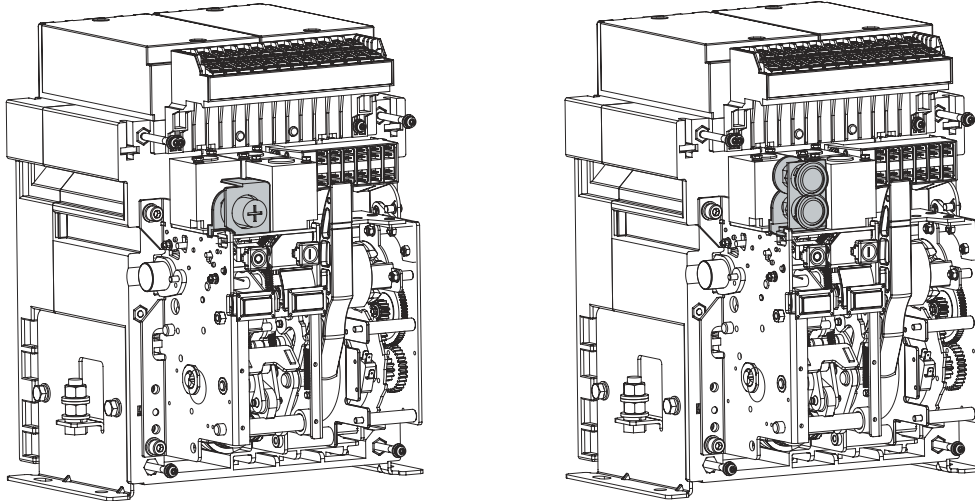

The open-position lock secures the trip button in the depressed position. When selected by the customer, we will install and configure it. Usage method:

(1) key lock:

One lock one key (SF11): One DC disconnecter with one same lock and one key, and only allowed to closed when locked.

Two locks one key (SF21): Two DC disconnecters with two same locks and one key, and only allowed one DC disconnecter closed.

Three locks one key (SF31): Three DC disconnecters with three same locks and one key, and only allowed one DC disconnecter closed.

Three locks two keys (SF32): Three DC disconnecters with three same locks and two keys, and only allowed two DC disconnecters closed.

Five locks three keys (SF53): Five DC disconnecters with five same locks and three keys, and only allowed three DC disconnecter closed.

(2) Double interlock (SF22): With two different sets of keys and locks.

## Phase separator

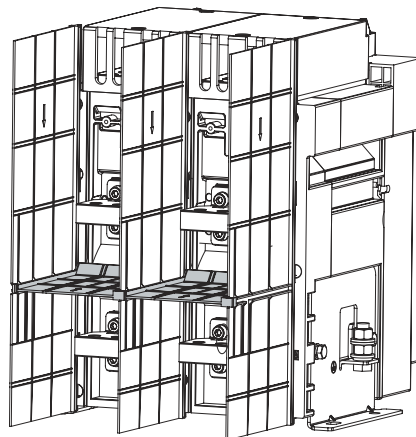
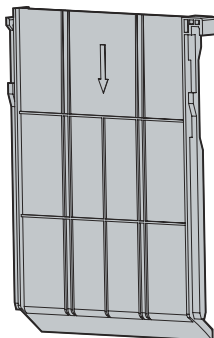

## Phase separator

Installed vertically between the terminal blocks of the fixed part of a fixed-mounted DC disconnect, it enhances the insulation strength at the busbar connection points and prevents arc propagation into the breaker's interior.

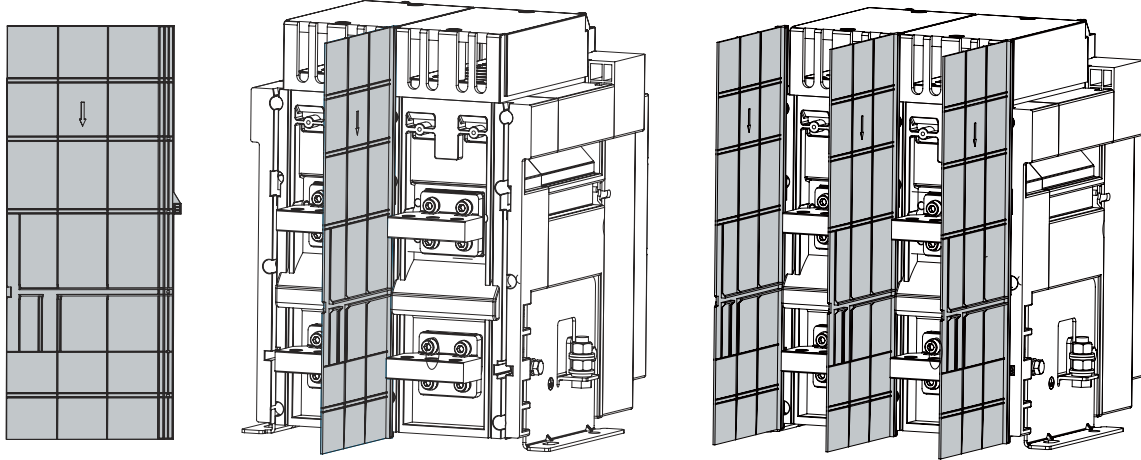

## Model Explanation and Encoding Rules

### Connection of Ground Terminal

It should be cleaned before grounding of the fixed type DC disconnector. And connect the PE wire to grounding bar of the switchgear by M12. The area of wire refers to the following table.

Cross-sectional area of phase wire ( mm <sup>2</sup> )	Corresponding protective conductor ( minimum cross-sectional area of PE ( mm <sup>2</sup> ) )
35 < S ≤ 400	S/2
400 < S ≤ 800	200
S > 800	S/4

### Temperature derated coefficient

The temperature and altitude correction factors for VW3GZ-16 and VW3GZ-40 can be referenced according to the following table:

If the ambient temperature is higher than +40°C, capacity can be corrected according to the following table.

Type	Rated current(A)In	+40°C	+45°C	+50°C	+55°C	+60°C	+65°C	+70°C
VW3GZ-16	200-1250	1.0	1.0	1.0	1.0	1.0	1.0	1.0
	1600	1.0	1.0	1.0	1.0	0.98	0.93	0.87
VW3GZ-40	6300-2500	1.0	1.0	1.0	1.0	1.0	/	1.0
	2900	1.0	1.0	1.0	1.0	1.0	/	0.96
	3200	1.0	1.0	1.0	1.0	0.94	/	0.92
	3600	1.0	1.0	1.0	0.94	0.92	/	0.9
	4000	1.0	0.95	0.92	0.89	0.95	/	0.85

### Altitude correction coefficient

Type	Project	Parameters				
VW3GZ-16	Altitude	2000	3000	4000	4500	5000
	Power frequency withstand voltage(V)	5000	4500	3500	/	2200
	Rated current(A)	1.0In	0.9In	0.8In	/	0.6In
	Rated working voltage(V)	DC1000 DC1500	DC1000 DC1500	DC1000 DC1500	/	DC1000 DC1500
	Rated Insulation voltage(V)	1600V	1600V	1600V	/	1600V
VW3GZ-40	Working current(A)	1.0In	0.9In	0.88In	0.85In	0.82In
	Breaking capacity	1.0	0.98	0.93	0.88	0.85

## Copper busbar specification

Frame size rated current $I_{nm}$ (A)	Rated current $I_n$ (A)	Copper busbar specification		
		Number of busbar		Dimension
		Horizontal wiring	Vertical wiring	
VW3GZ-16	≤630	1		50×5
	800	1		50×10
	1000	1		50×10
	1250	2		50×10
	1600	2		50×10
VW3GZ-40	630	2	1	80×5
	800	2	1	80×5
	1000	2	1	80×5
	1250	2	1	100×5
	1600	2	1	100×5
	2000	3	2	100×5
	2500	4	3	100×5
	2900	3	2	100×10
	3200	4	3	100×10
	3600	5	4	100×10
	4000	5	4	100×10

**Note 1:** The table shows that the DC disconnect is installed in an open environment with a maximum ambient temperature of 40 °C and meets the copper bar specifications specified in GB/T 14048.3 for heating conditions. If the temperature exceeds 40 °C, the breaking capacity should be reduced or the number of copper bars should be increased.

**Note 2:** The maximum allowable temperature for copper bars should not exceed 110 °C.

### Recommended screw used of outlet busbar diameter

Switch Disconnecter type	Outlet busbar diameter	Screws grade 8.8 (with washer)	Tightening torque
VW3GZ-16	Φ11	M10	50N.m
VW3GZ-40	Φ13	M12	70N.m

### Wiring method for copper bars

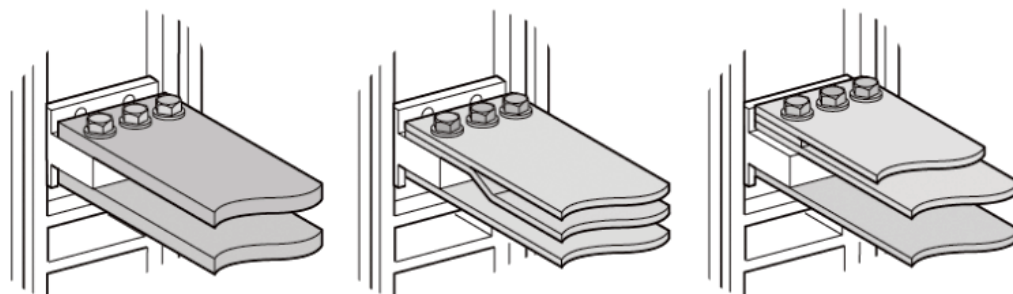

## VW3GZ-16 Electrical wiring Diagram

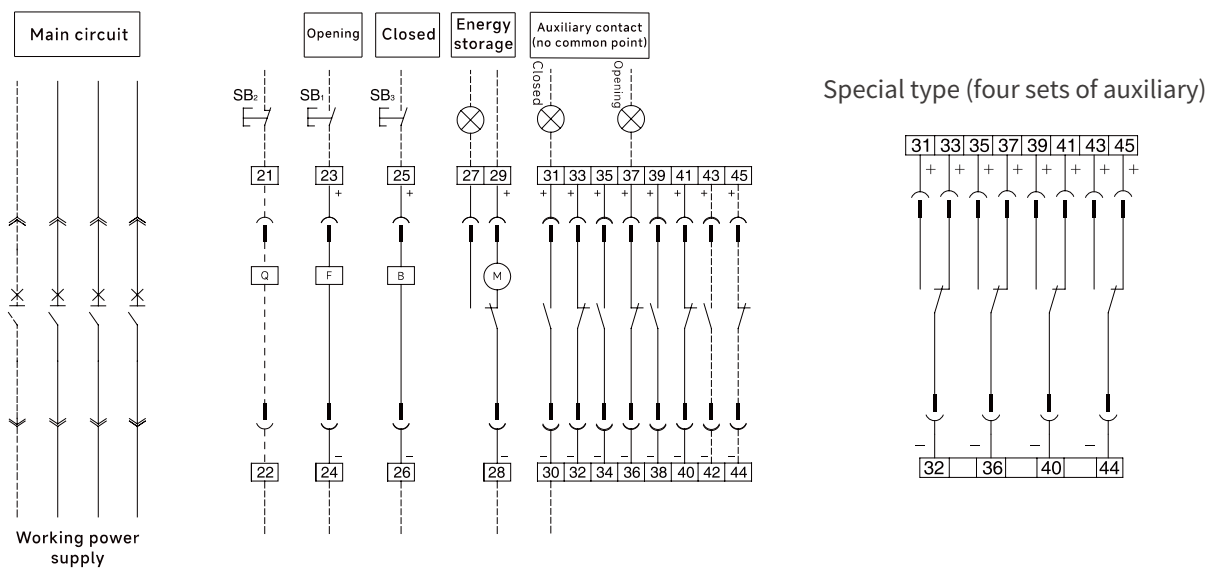

**Note:** SB1 Shunt button      SB3 Close button      F Shunt release  
 B Closed electromagnet      M Motor operating mechanism

Terminal Number	
21#, 22#	Under-voltage release or loss of voltage release
23#, 24#	Shunt release
25#, 26#	Closed electromagnet
27#, 28#, 29#	Motor operating mechanism
30#~45#	Auxiliary contact

**Note:**

- 1) the Q, F, B, M can be with different power supply voltage;
- 2) Terminal 29# can be directly connected to the power supply (automatic pre energy storage), it can also be connected to the normally open button and then to the power supply (manually controlled pre energy storage);
- 3) The buttons and indicator should be provided by the user;
- 4) If the control power supply is DC, please connect the positive and negative wire

## VW3GZ-40 Electrical wiring Diagram

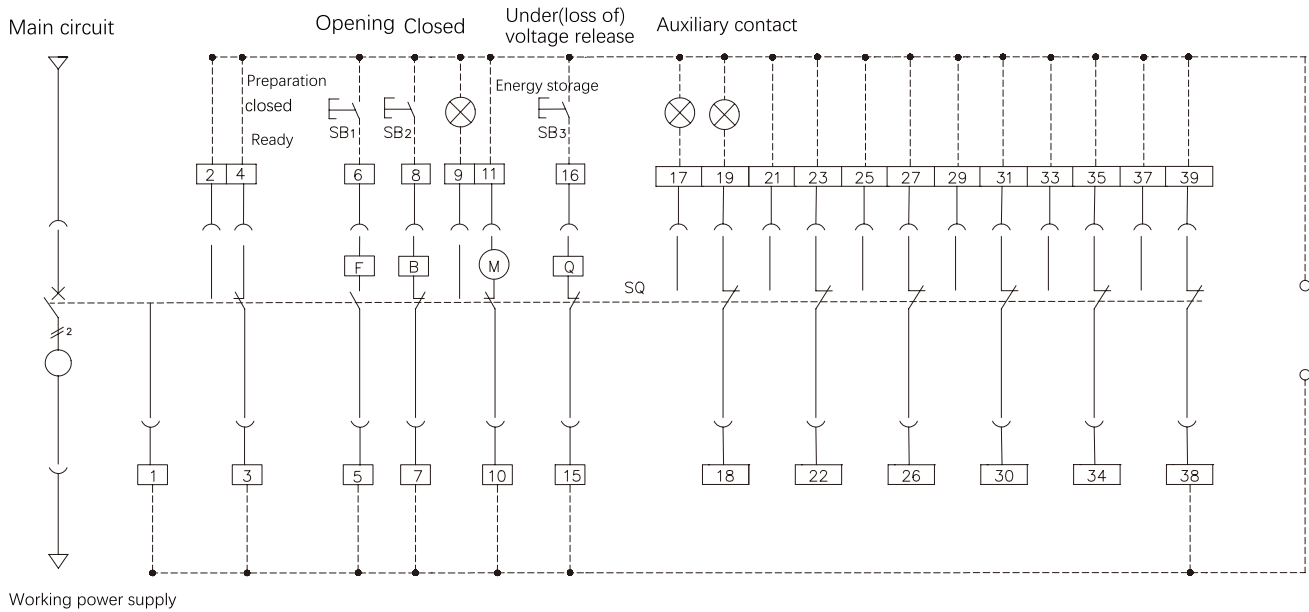

**Note:**

- SB1** Open button      **SB3** Undervoltage release button      **B** Closed electromagnet      **SQ** Auxiliary contact
- SB2** Close button      **F** Shunt release      **M** Motor operating mechanism

Terminal Number Description	
1#	Grounding terminal
2#、3#、4# (Optional)	Closing ready terminal
5#、6#	Shunt release terminal
7#、8#	Closing release terminal
9#、10#、11#	Motor operator terminal
15#、16# (Optional)	Undervoltage release terminal
17#-28#	Auxiliary contact terminal 3no3nc
29#-40# (Optional)	Auxiliary contact terminals

**Note:**

External wiring diagram shows buttons and indicators to be provided by the user

## VW3GZ-40 Electrical Wiring Diagram (No common point)

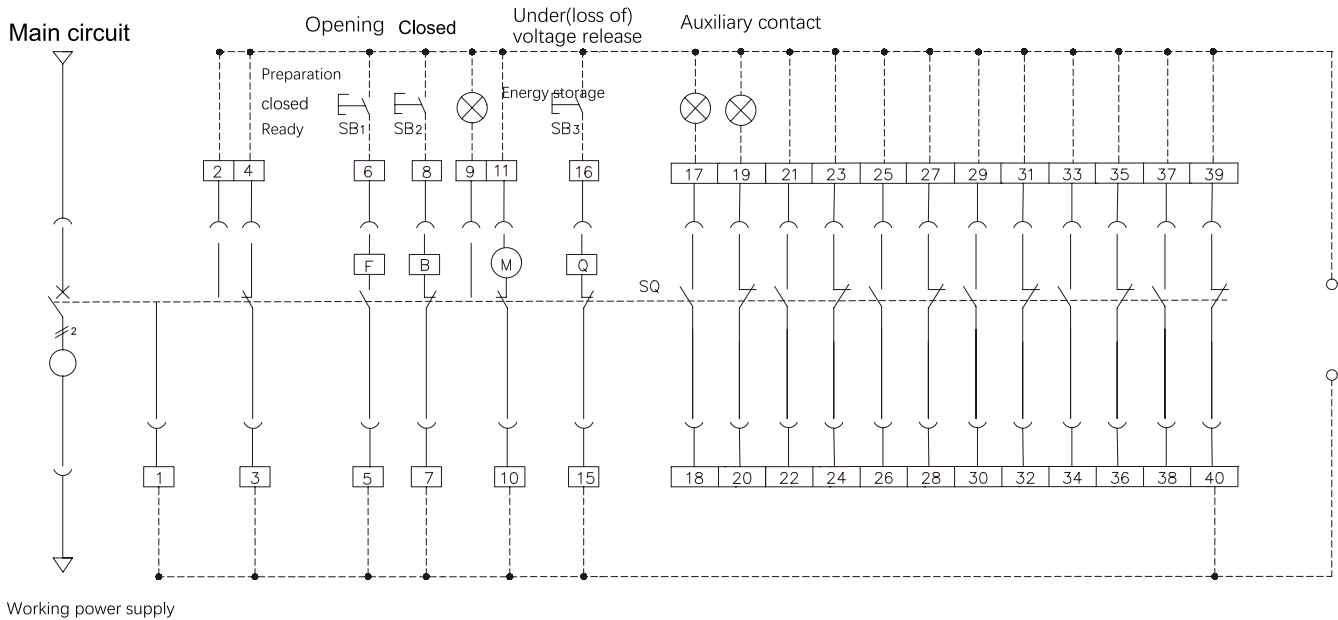

**Note:**

- SB1** Open button      **SB3** Undervoltage release button      **B** Closed electromagnet      **SQ** Auxiliary contact
- SB2** Close button      **F** Shunt release      **M** Motor operating mechanism

Terminal Number Description	
1#	Grounding terminal
2#, 3#, 4# (Optional)	Closing ready terminal
5#, 6#	Shunt release terminal
7#, 8#	Closing release terminal
9#, 10#, 11#	Motor operator terminal
15#, 16# (Optional)	Undervoltage release terminal
17#-28#	Auxiliary contact terminal 3no3nc
29#-40# (Optional)	Auxiliary contact terminals

**Note:**

External wiring diagram shows buttons and indicators to be provided by the user

## Fixed type (VW3GZ-16, 200-1600A)

### Front view

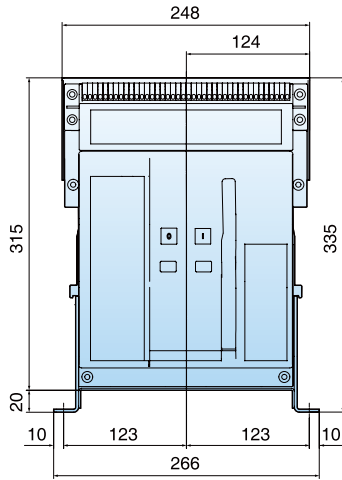

3 pole

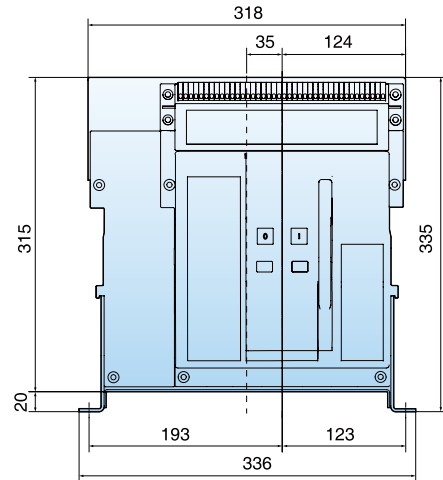

4 pole

### Vertical Wiring

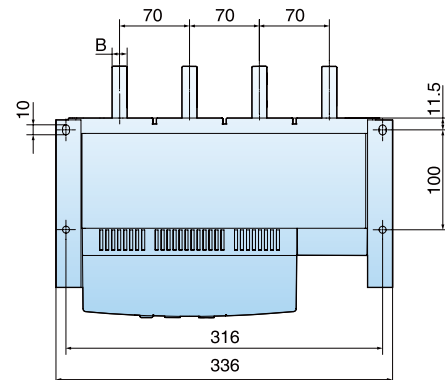
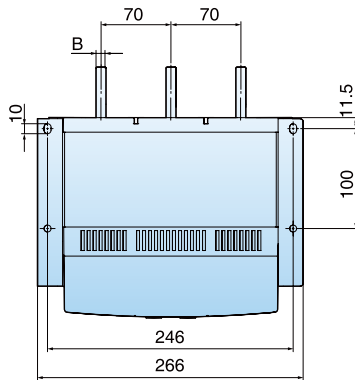

Distance for dismantling the arc extinguishing chamber

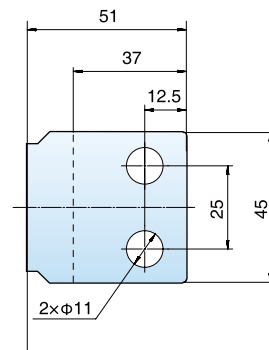
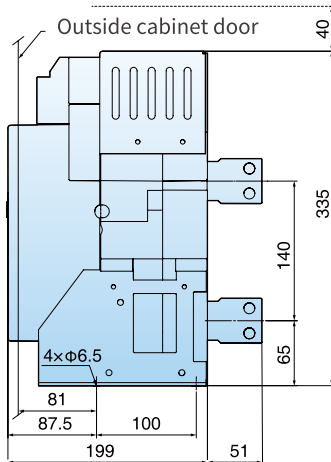

Current	VW3GZ-16 (200~1250A)	VW3GZ-16 (1600A)
Dimension B (mm)	10	15

## Horizontal Wiring

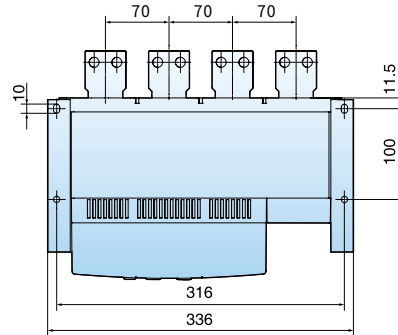
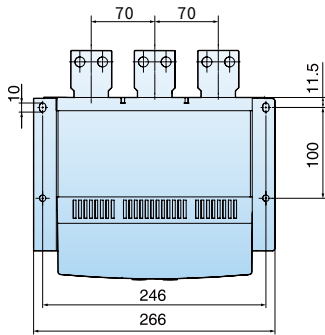

Distance for dismantling the arc extinguishing chamber

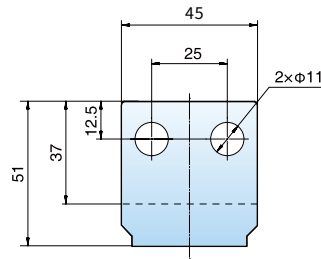
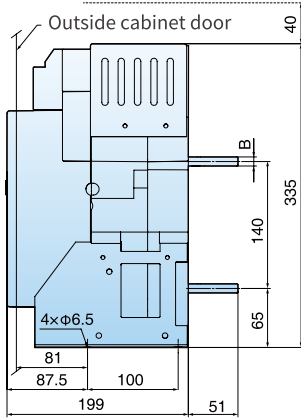

## Cabinet door open hole dimension

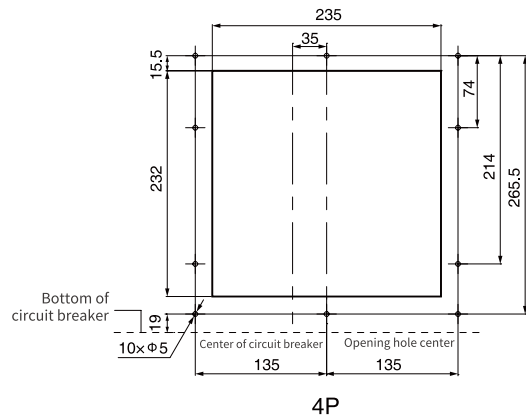
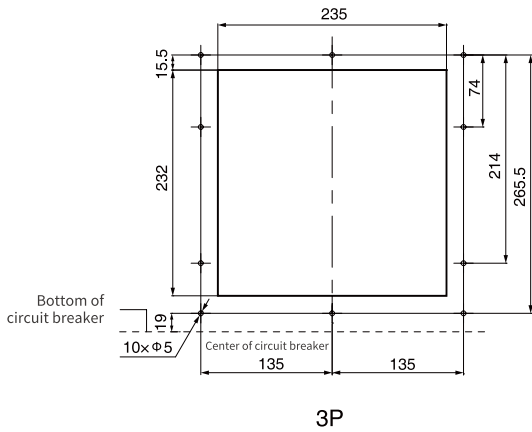

## Fixed type (VW3GZ-40, 630~2500A)

Front view

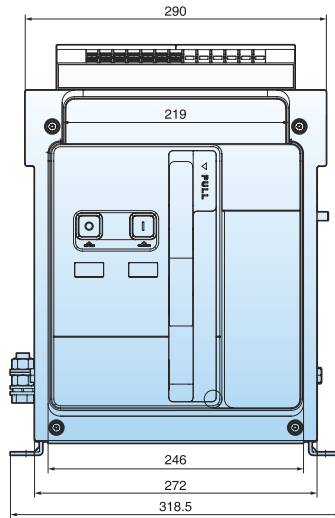

Vertical Wiring

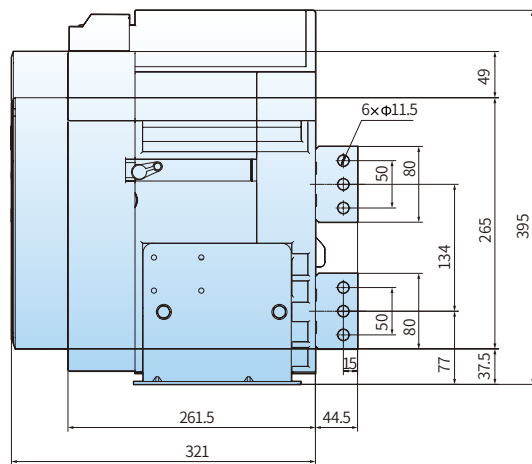
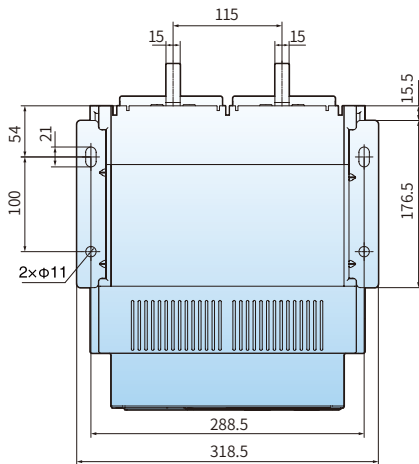

Horizontal Wiring

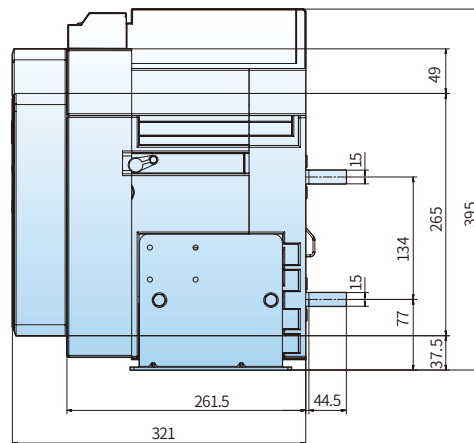
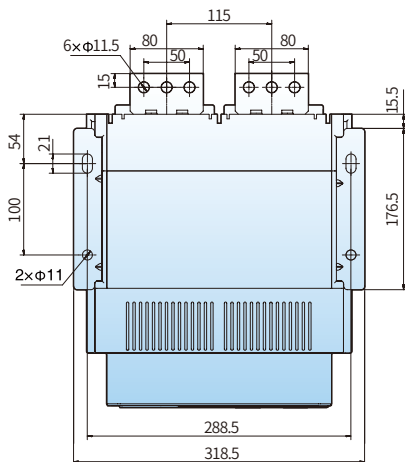

## Fixed type (VM3GZ-40, 2900-3200A)

Front view

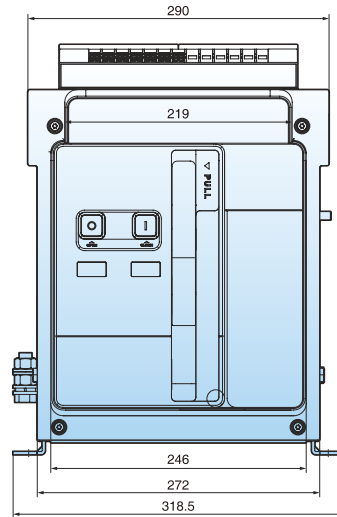

Vertical Wiring

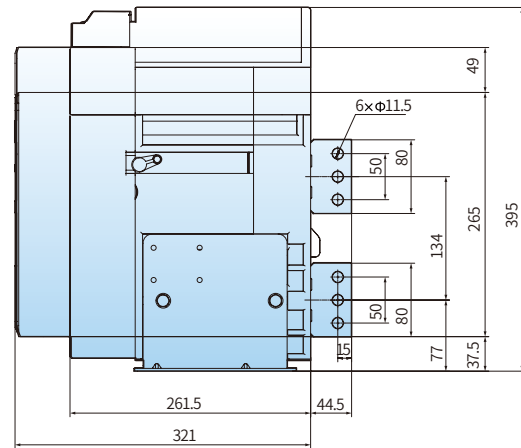
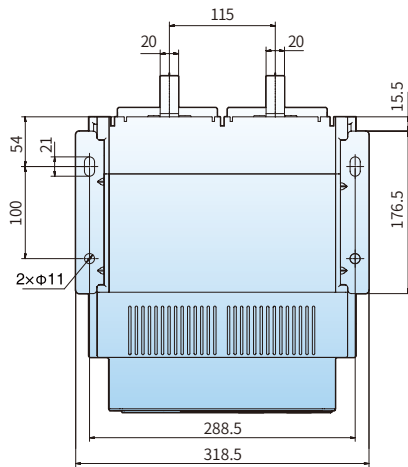

Horizontal Wiring

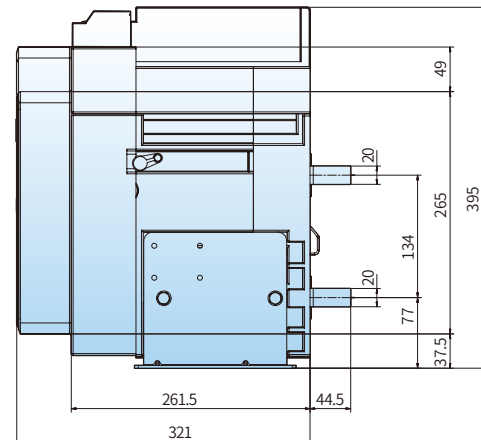
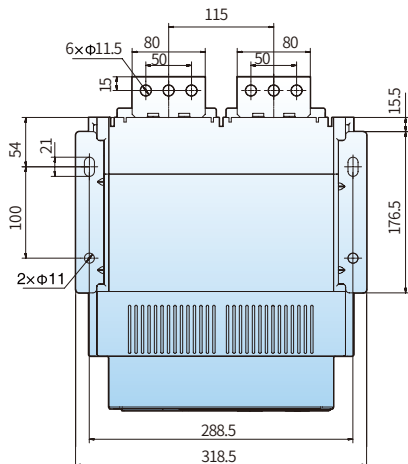

## Fixed type (VW3GZ-40, 3600-4000A)

### Front view

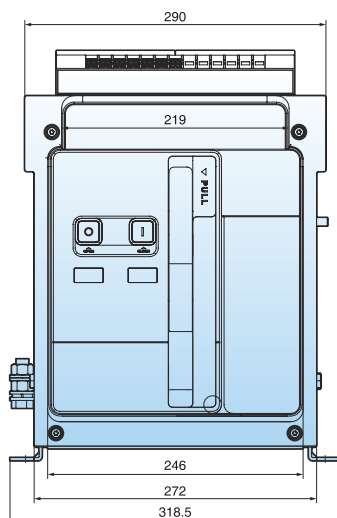

### Vertical Wiring

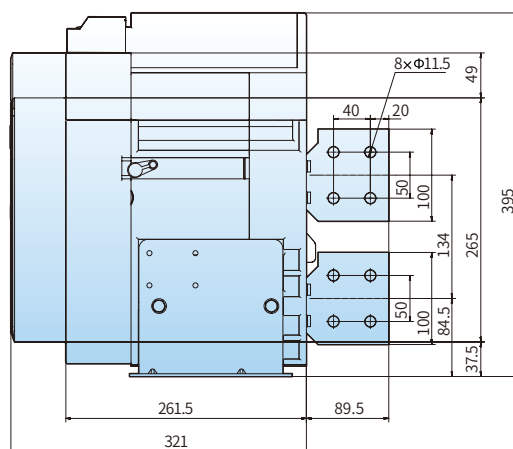
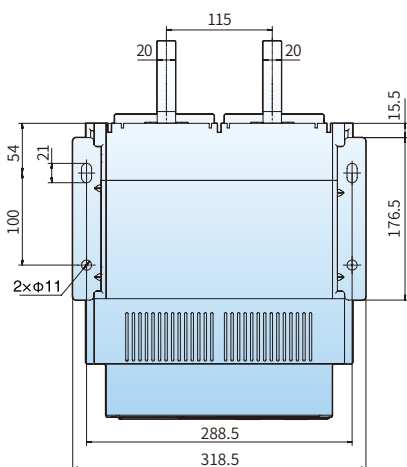

### Horizontal Wiring

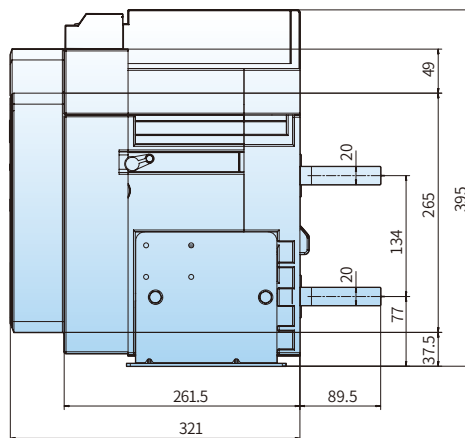
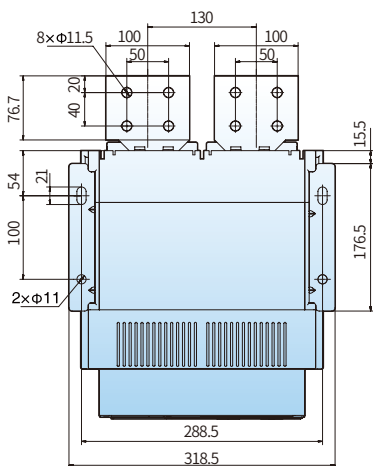

# Size and Connection

The selection of switchgear in DC systems mainly considers the following aspects:

- Rated working voltage, considering the number of series connected poles for disconnection
  - Rated current, considering load power
  - Grounding system method
- a. Three pole series isolation switch - B-type wiring method  
 b. Four pole series isolation switch - C-type wiring method

## Recommended wiring method for VW3GZ-16 DC disconnect

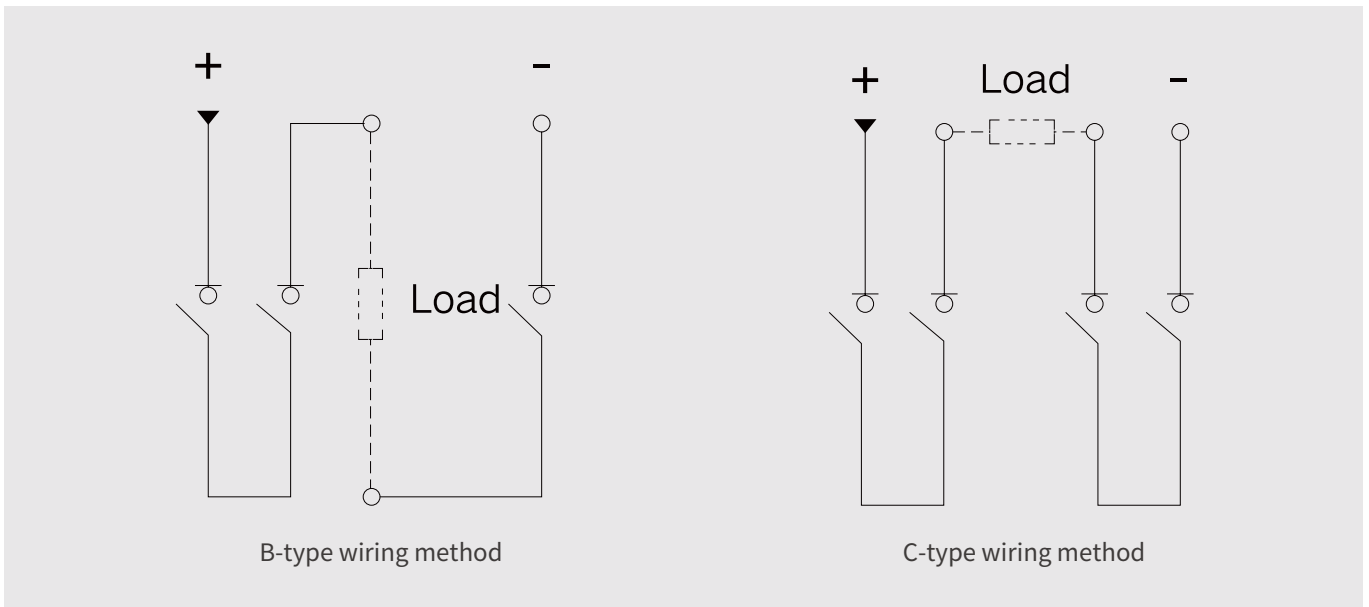

**Note:** If directly connected in parallel or series with the busbar, the continuous load of the isolating switch can only be 80% of the maximum operating current due to heating reasons. If parallel or series connections are made at a distance of 1 meter from the busbar, the switch disconnecter can operate at full load.

## Recommended wiring method for VW3GZ-40 DC disconnect

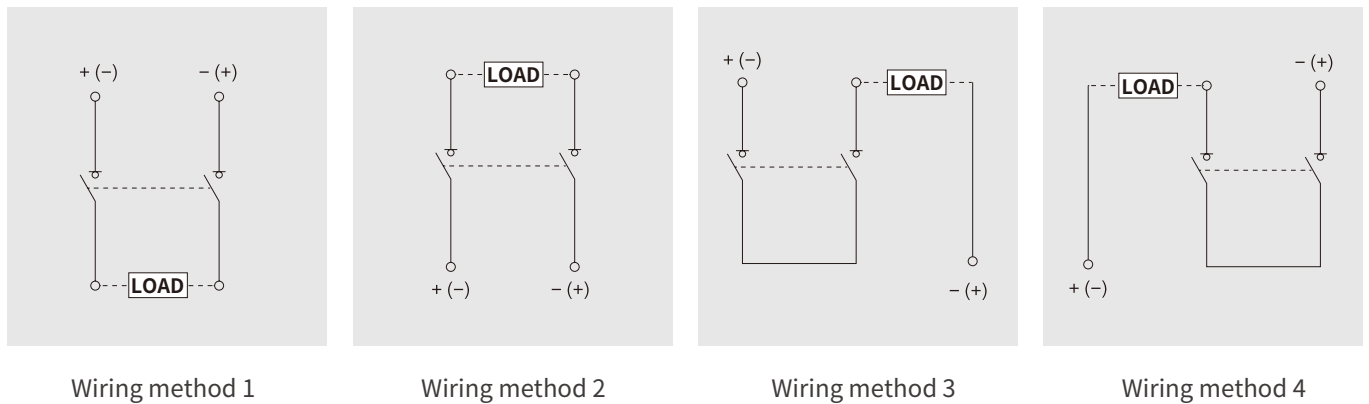

When users install the DC disconnecter into the cabinet, the safe distance between the DC disconnecter and the cabinet is shown in the figure below, and the installation dimensions are shown in the table below.

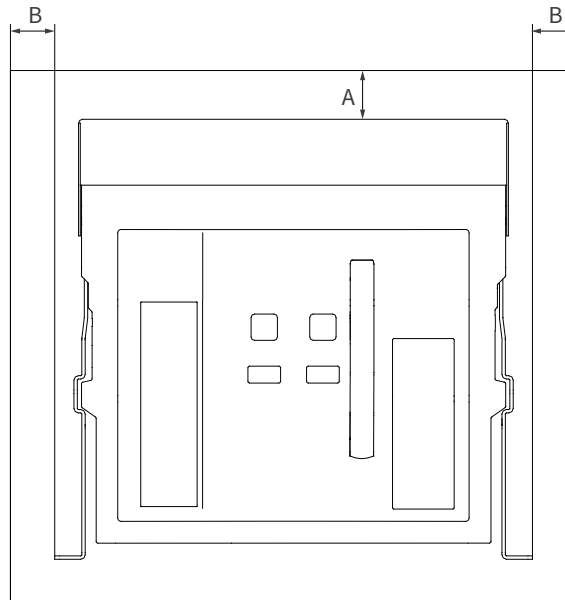

**Fixed type DC disconnecter**

unit: mm

Fixed type	To the insulator		To the metallic body grounded safely		To the live part	
	A	B	A	B	A	B
VW3GZ-16	0	0	0	0	60	60
VW3GZ-40	0	0	0	0	80	80

**Note:** The safety distance for fixed switches should consider a space of 40mm required to remove the arc extinguishing chamber;

Please fill in numbers in, and check  in

User: Number of units ordered: Date of ordering:		
Basic parameters	Shell frame level	<input type="checkbox"/> VW3GZ-1600 <input type="checkbox"/> VW3GZ-4000
	Installation mode	F-Fixed type
	Rated current(A)	VW3GZ-1600 <input type="checkbox"/> 200 <input type="checkbox"/> 400 <input type="checkbox"/> 630 <input type="checkbox"/> 800 <input type="checkbox"/> 1000 <input type="checkbox"/> 1250 <input type="checkbox"/> 1600 VW3GZ-4000 <input type="checkbox"/> 630 <input type="checkbox"/> 800 <input type="checkbox"/> 1000 <input type="checkbox"/> 1250 <input type="checkbox"/> 1600 <input type="checkbox"/> 2000 <input type="checkbox"/> 2500 <input type="checkbox"/> 2900 <input type="checkbox"/> 3200 <input type="checkbox"/> 3600 <input type="checkbox"/> 4000
	Breaking type	<input type="checkbox"/> Empty: Standard breaking level
	Number of poles	<input type="checkbox"/> 2-2P <input type="checkbox"/> 3-3P <input type="checkbox"/> 4-4P Note:(2P only for VW3GZ-4000)
	Wiring mode	VW3GZ-1600: <input type="checkbox"/> C1-Standard Horizontal Wiring <input type="checkbox"/> C2-Standard Vertical Wiring VW3GZ-4000: <input type="checkbox"/> C1-Horizontal wiring <input type="checkbox"/> C2-Vertical wiring <input type="checkbox"/> C4-Mixed wiring(upper horizontal,lower vertical) <input type="checkbox"/> C5-Mixed wiring(upper vertical,lower horizontal) <input type="checkbox"/> 1-Standard wiring
Required accessories	Electric operating mechanism	<input type="checkbox"/> D1-AC400V <input type="checkbox"/> D2-AC230V/DC220V <input type="checkbox"/> D4-AC/DC110V <input type="checkbox"/> D5-DC24V
	Shunt release	<input type="checkbox"/> F1-AC400V <input type="checkbox"/> F2-AC230V/DC220V <input type="checkbox"/> F4-AC/DC110V <input type="checkbox"/> F5-DC24V
	Closed electromagnet	<input type="checkbox"/> B1-AC400V <input type="checkbox"/> B2-AC230V/DC220V <input type="checkbox"/> B4-AC/DC110V <input type="checkbox"/> B5-DC24V
Optional accessories	Under-voltage release	Voltage specifications <input type="checkbox"/> Q1-AC400V <input type="checkbox"/> Q2-AC230V <input type="checkbox"/> Q5-DC24V
		Delay time <input type="checkbox"/> 0-Instantaneous <input type="checkbox"/> 1-1s delay <input type="checkbox"/> 3-3s delay <input type="checkbox"/> 5-5s delay
	Loss of voltage release	Voltage specifications <input type="checkbox"/> S1-AC400V <input type="checkbox"/> S2-AC230V
		Delay time <input type="checkbox"/> 0-Instantaneous <input type="checkbox"/> 1-1s delay <input type="checkbox"/> 3-3s delay <input type="checkbox"/> 5-5s delay
	Auxiliary contact	<input type="checkbox"/> A33-3NO3NC <input type="checkbox"/> A44-4NO4NC <input type="checkbox"/> A55-5NO5NC <input type="checkbox"/> A66-6NO6NC <input type="checkbox"/> ___NO___NC(Max.14)
		<input type="checkbox"/> A3-Three-group switching <input type="checkbox"/> A4-Four-group switching <input type="checkbox"/> BX-Closing ready signal output unit <input type="checkbox"/> A6-Six-group switching <input type="checkbox"/> ___-group switching(Max.14)
	Closing ready	<input type="checkbox"/> BX-Closing ready signal output unit
	Counter	<input type="checkbox"/> JS-Counter Note: (JS only for VW3GZ-40)
Door frame	<input type="checkbox"/> M-Door frame Note: (M only for VW3GZ-16)	
Button lock	<input type="checkbox"/> S-Button lock	
Language type	<input type="checkbox"/> Chinese <input type="checkbox"/> Y-English	
Interlocking Off-position lock accessories	<input type="checkbox"/> SF11-Key lock device(one lock and one key) <input type="checkbox"/> SF21-Key lock device(two locks and one key) <input type="checkbox"/> SF31-Key lock device (three locks and one key) <input type="checkbox"/> SF22-Key lock device(two locks and two keys) <input type="checkbox"/> SF32: Key lock device(three locks and two keys) <input type="checkbox"/> SF53: Key lock device (five locks and three keys)	
Mechanical interlocking	<input type="checkbox"/> SR11-two sets of steel cables, one for closing and one for opening <input type="checkbox"/> SR12-three sets of steel cables, one for closing and two for opening <input type="checkbox"/> SR21-three sets of steel cables, two for closing and one for opening <input type="checkbox"/> SY11-two sets of hard rods, one for closing and one for opening	
Other requirements		

# VM3

Molded Case Circuit Breaker





- Tailored for solar energy and wind power
- With higher breaking capacity
- With excellent anti damp heat and dew solidification capabilities
- Working voltage up to 1000V
- Strong ability to adapt to alternating changes in high and low temperatures
- High altitude adaptability

## Ambient conditions

### Operating ambient temperature/storage temperature

- Operating environment temperature: -40 °C~+70 °C, with an average value of no more than +35 °C within 24 hours
- Storage temperature: -40 °C~+75 °C

### Altitude conditions

- Altitude of installation site  $\leq$  2000m (Over 2000 meters need capacity reduction for using)

### Pollution level

- Level 3

### Protection level

- Product protection level: IP20

### Installation Category

- Class II (load) and Class III (distribution and control)

### Installation Environment

- The product is installed in a medium without explosion risk, and the medium is not sufficient to corrode metal, there is no gas that damages the insulation layer of the product, there is no conductive dust, and it should be avoided from being used in places invaded by rain and snow

### Environmental requirements

- The product meets RoHS standards

## VM3 Series Molded Case Circuit Breaker (TMF)

## VM3-250HUL

## VM3-250HUM



Poles			
Control	Rotary handle operator		
	Motor-operated mechanism		
Connection	Wiring in front of the board		
	Wiring on back of the board		
	Plug-in		
	Draw-out		
IEC 60947-2			
Release rated current $I_n$ (A)			
Rated insulation voltage(V)		$U_i$	
Rated impulse withstand voltage(kV)		$U_{imp}$	
Rated operating voltage(V)		$U_e$	
Breaker Type			
Rated ultimate short circuit breaking capacity(kA)	$I_{cu}$	AC 50/60 Hz	400V
			500V
			690V
			800V
			1000V
Rated service short circuit breaking capacity(kA)	$I_{cs}$	AC 50/60 Hz	400V
			500V
			690V
			800V
			1000V
Utilization category			
Number of operation cycles	Machinery		
	Electrical	AC400V	
		AC500V	
		AC690V	
		AC800V	
		AC1000V	
Protection unit			
Protection unit			
Overload protection	Long time delay	$I_r (I_n \times \dots)$	
Short-circuit protection	Instantaneous	$I_i (I_n \times \dots)$	
Indication and control accessories			
Alarm switch(AL)			
Auxiliary switch(AX)			
Shunt release(SHT)			
Under-voltage release(UVT)			
Installation			
Accessories	Terminal		
	Phase separator		
Outline dimension (mm) (H × W × D)			

3P
■
■
■
—
—
—
63, 80, 100, 125, 140, 160, 180, 200, 225, 250 AC1150
8
AC800
L
/
/
/
30
/
/
/
23
/
A
10000
/
/
/
1500
1500
1000
Thermal-Magnetic
■
■
■
■
■
■
200 × 116 × 107

3P
■
■
■
—
—
—
63, 80, 100, 125, 140, 160, 180, 200, 225, 250 AC1150
8
AC800/AC1000
M
/
/
/
40
/
/
/
36.5
/
15
A
10000
/
/
/
1500
1500
1000
Thermal-Magnetic
■
■
■
■
■
■
200 × 116 × 107

**Note :** 1.HUL,HUM,HUH type only provides front wiring of 3P;  
2.The symbol "-" indicates that this option is not available; The symbol "■" indicates that this option is optional.

## VM3 Series Molded Case Circuit Breaker (TMF)

## VM3-250HUH

## VM3-630HUL



<b>Poles</b>			
Control	Rotary handle operator		
	Motor-operated mechanism		
Connection	Wiring in front of the board		
	Wiring on back of the board		
	Plug-in		
	Draw-out		
<b>IEC 60947-2</b>			
Release rated current $I_n$ (A)			
Rated insulation voltage(V)		$U_i$	
Rated impulse withstand voltage(kV)		$U_{imp}$	
Rated operating voltage(V)		$U_e$	
<b>Breaker Type</b>			
Rated ultimate short circuit breaking capacity(kA)	Icu	AC 50/60 Hz	400V
			500V
			690V
			800V
			1000V
Rated service short circuit breaking capacity(kA)	Ics	AC 50/60 Hz	400V
			500V
			690V
			800V
			1000V
<b>Utilization category</b>			
Number of operation cycles	Machinery		
		Electrical	AC400V
			AC500V
	AC690V		
	AC800V		
	AC1000V		
<b>Protection unit</b>			
Protection unit			
Overload protection	Long time delay	$I_r (I_n \times \dots)$	
Short-circuit protection	Instantaneous	$I_i (I_n \times \dots)$	
<b>Indication and control accessories</b>			
Alarm switch(AL)			
Auxiliary switch(AX)			
Shunt release(SHT)			
Under-voltage release(UVT)			
<b>Installation</b>			
Accessories	Terminal		
	Phase separator		
Outline dimension (mm) (H × W × D)			

3P
■
■
■
—
—
—
63,80,100,125,140,160, 180,200,225,250 AC1150
8
AC800
H
/
/
/
50
/
/
/
36.5
/
/
36.5
/
15
A
10000
/
/
/
1500
1500
1000
Thermal-Magnetic
■
■
■
■
■
200 × 116 × 107

3P
■
■
■
—
—
—
200,250,315,350,400
8
AC800/AC1000
L
/
/
/
36.5
/
/
36.5
/
15
A
10000
/
/
/
1500
1500
1000
Thermal-Magnetic
■
■
■
■
■
257 × 150 × 103

**Note :** 1.HUL,HUM,HUH type only provides front wiring of 3P;  
2.The symbol "-" indicates that this option is not available; The symbol "■" indicates that this option is optional.

# Selection Guide

# VOZWEI

<b>VM3</b>	–	<b>250</b>	<b>HU</b>	<b>M</b>	<b>250</b>	/	<b>TMF</b>	/	<b>3</b>	/	<b>AX/SHT</b>
1		2	3	4	5		6		7		8

SN	Name	Specification, type code	
1	Design code	VM3: Design code	
2	Frame rating	250: 250A 630: 630A	
3	High voltage type	HU: High voltage	
4	Breaking capacity	L, M, H	
5	Rated current	63~400A	
6	Protection unit type	TMF: Thermal magnetic protection unit (For power distribution protection)	
7	Number of poles	3P	
8	Accessories (separated with"/" between different accessories)	Connection accessories	Empty: Fixed type wiring in front of the board
		Electrical accessories	AL: Alarm contact AX: Auxiliary contact SHT: Shunt release UVT: Under-voltage release
		Control Accessories Note: VM3-630HU optional	CD2: Motor operator CS1: Manual operator CS2: Manual operator-eccentric CS3: Box-type manual operator eccentric SF: Rotary handle F type SR: Rotary handle R type

## \* Electrical accessories

Accessories	Voltage				
SHT Shunt release	AC230V	AC400V	DC220V	AC/DC110V	DC24V
UVT Under-voltage release	AC230V	AC400V			
Motor operator	AC110V	AC230V	DC110V	AC/DC220V	DC24V

If the accessory voltage and voltage control loop is inconsistent, please use indicate the accessory voltage after accessory.

### Example

#### **VM3-250HUL250/TMF/3/AX/SHT (AC230)**

Meaning: VM3 series circuit breaker; the frame level is 250A; breaking capacity is 30kA, 3 poles; rated current is 250A; fixed type wiring on front of the board; accessory contains auxiliary contact and shunt release with voltage (AC230V).

**Notice:** 1. HU type only provides front wiring of 3P.

# Main Characteristic



## TMF Protection unit

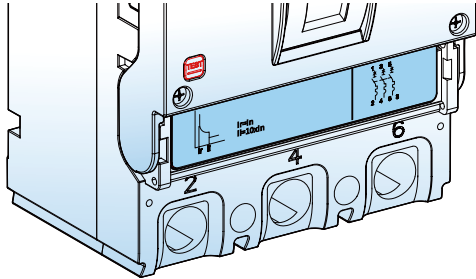

**TMF:** Thermal magnetic protection unit (For power distribution protection)

## TMF Sign interpretation

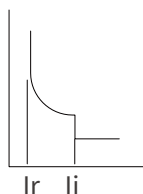

Protection curve

$I_r = I_n$   
 $I_i = 10 \times I_n$

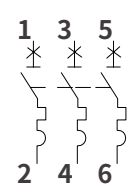

Protection unit type

## TMF Protection characteristics

TMF: Data sheet of protection characteristics

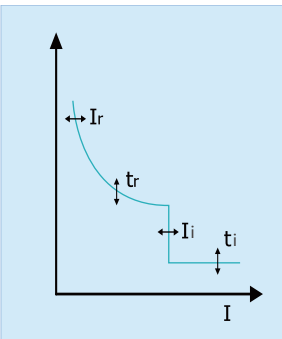

Rated current(A)	Inverse time acting characteristic (Ambient air temperature +40°C)		Instantaneous acting current(A)
	1.05I <sub>n</sub> (Cold state) Not acting time	1.3I <sub>n</sub> (Hot state) Acting time	
I <sub>n</sub> ≤ 63	≥ 1h	< 1h	10I <sub>n</sub> ± 20%
63 < I <sub>n</sub> ≤ 800	≥ 2h	< 2h	

## TMF Protection unit power loss

## Power loss

Circuit Breaker Model	Rated current(A)	Total power loss of three-phase(W)	
		Wiring in front of the board, Wiring on back of the board	Plug-in / Wiring on back of the board
VM3-250	250	35	40
VM3-630	630	43	51

## Derated coefficient of rated current

Circuit Breaker Model	+40°C	+45°C	+50°C	+55°C	+60°C	+65°C	+70°C
VM3-250	1.0 I <sub>n</sub>	1.0 I <sub>n</sub>	1.0 I <sub>n</sub>	1.0 I <sub>n</sub>	0.98 I <sub>n</sub>	0.95 I <sub>n</sub>	0.92 I <sub>n</sub>
VM3-630	1.0 I <sub>n</sub>	1.0 I <sub>n</sub>	1.0 I <sub>n</sub>	1.0 I <sub>n</sub>	0.97 I <sub>n</sub>	0.94 I <sub>n</sub>	0.91 I <sub>n</sub>

## Derated coefficient of high altitude of VM3 series MCCB

Item	Parameter						
Elevation	2000	2500	3000	3500	4000	4500	5000
Power frequency withstand voltage(V)	3000	3000	2500	2400	2200	2200	2200
Isolation voltage	1	1	0.95	0.91	0.87	0.87	0.87
Breaking capacity correction factor	1	1	0.95	0.91	0.87	0.80	0.74
Working current correction factor	1	1	0.98	0.97	0.96	0.95	0.94

Electrical accessories

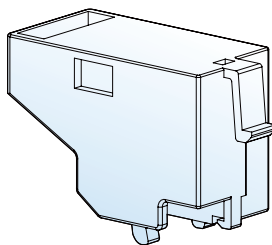

Alarm contact (AL)

Alarm contact (AL)

Function

The product outputs alarm signal when it is tripped by outer excitation signal due to overload, short circuit, undervoltage, or when the release button is pressed. This function is particularly useful in an automatic system, since that a fault signal can be sent to the designated place. And the fault signal will turn on due to an internal microswitch, when circuit breaker releases. But for normal opening or closing operations, it does not have any action.

Alarm contact operating characteristics

Circuit breaker status	Alarm contact status
The statuses of open and close	
The statuses of tripping	

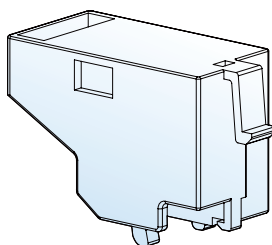

Auxiliary contact (AX)

Auxiliary contact (AX)

Function

Auxiliary switch is used for indication of remote "ON" and "OFF". Each switch contains two contacts, which share a common end of connection. The ON/OFF position depends on the state of main contact. When the circuit breaker is open, one of them is normally open, and the other is closed, or vice versa.

Auxiliary contact operating characteristics

Circuit breaker status	Auxiliary contact status
The statuses of open	
The statuses of close	

Alarm contact,Auxiliary contact rated operational current

Classification	Rated current Inm	Conventional thermal current Ith(A)	Rated working current Ie(A)	
			AC400V	DC220V
Auxiliary contact	≤250	3	0.3	0.15
	400≤Inm≤1000	3	0.4	0.2
Alarm contact	10≤Inm≤1000	-	AC220V/1.0A	0.15

ON-OFF capacity of Alarm contact and Auxiliary contact under normal conditions

Utilization category	ON				OFF				Number of operation cycles	Number of operation cycles per minute	Power time
	I/Ie	U/UE	cosφ	T0.95	I/Ie	U/UE	cosφ	T0.95			
AC-15	10	1	0.7	-	1	1	0.7	-	6050	6	≥ 0.05s
DC-13	1	1	-	6 × Pe	1	1	-	6 × Pe			≥ 0.05s

ON-OFF capacity of Alarm contact and Auxiliary contact under abnormal conditions

Utilization category	ON				OFF				Number of operation cycles	Number of operation cycles per minute	Power time
	I/Ie	U/UE	cosφ	T0.95	I/Ie	U/UE	cosφ	T0.95			
AC-15	6	1	0.7	-	1	1	0.7	-	-	-	≥ 0.05s
DC-13	1.1	1.1	-	6 × Pe	1.1	1.1	-	6 × Pe	10	6	≥ 0.05s

- Note:** 1.  $T_{0.95}=6Pe$  is an empirical formula in which the unit of "Pe" is watt and the unit of  $T_{0.95}$  is millisecond.  
 2. The number of operation of Auxiliary contact can equal to that of the circuit breaker, if the number of operation of circuit breaker is less than 6050.  
 3. The operation frequency and power-on time of an auxiliary contact are allowed to be the same as those of the main circuit.  
 4. If  $T_{0.95}$  is more than 0.05s, the power-on time is at least  $T_{0.95}$ .

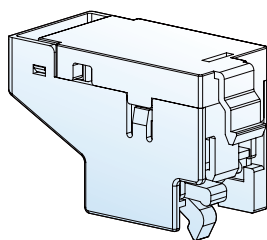

Shunt release (SHT)

Shunt release (SHT)

Function

Shunt release refers to the device which disconnect circuit breaker with current from a distance. A shunt release can cut off the signal circuit automatically after tripping.

Operating Characteristics

Voltage specification	AC50Hz: 110V 230V 400V DC: 24V 110V 220V
Operating characteristics	When the operation voltage is 70%~110% of the rated control voltage, the shunt release should trip the circuit breaker reliably.

Connection diagram (internal accessories of a circuit breaker)

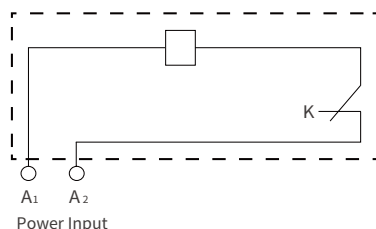

K is a microswitch closed contact of micro switch installed in series with the coil in shunt tripper, when the breaker is tripping, the switch is off by itself, when the breaker is closing, and then the switch is on.

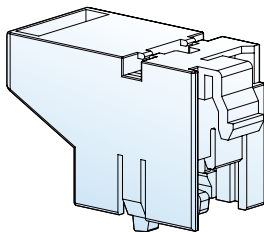

Under-voltage release (UVT)

### Under-voltage release (UVT)

#### Function

Under-voltage release is a device which can automatically disconnect the circuit breaker when voltage is reduced.

#### Operating characteristics of the under-voltage release

Rated operational voltage	AC400V AC230V
Operating Characteristics	When the operation voltage is 70%~110% of the rated control voltage, the under-voltage release should trip the circuit breaker reliably.
	When the working voltage is 85%~110% of the rated voltage, the under-voltage release should make the circuit breaker switch on.
	When the working voltage is less than 35% of the rated voltage, the under-voltage release should prevent the circuit breaker from being switched on.

#### Wiring diagram of under-voltage release module (the internal accessories of circuit breaker are depicted in the dotted area)

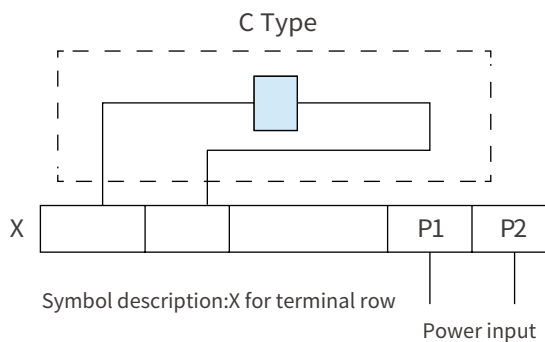

#### Under-voltage release power meter

Equipped with circuit breaker type	Under-voltage release power	
	AC230V	AC400V
VM3-630 (Thermal-magnetic)	0.75	0.75



*Before switch on a circuit breaker, the undervoltage release must be electrified otherwise the circuit breaker may be damaged.*

## Electrical accessories (TMF)

### Combined mode of electrical accessories

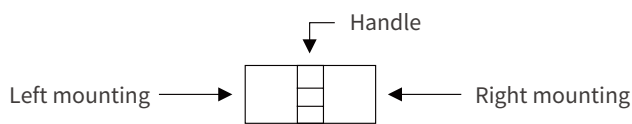

- Alarm switch
- Auxiliary switch
- Shunt release
- Under-voltage release
- Output lead direction

Accessory code	Accessory name	Model	
		VM3-250	VM3-630
		3	3、4 <sup>①</sup>
AL	Alarm contact		
AX	Auxiliary contact		
SHT	Shunt release		
UVT	Under-voltage release	/	
SHT + UVT	Shunt release and under-voltage release	/	
AL+AX	Alarm contact and auxiliary contact		
AL+SHT	Alarm contact and shunt release		
AL+UVT	Alarm contact and under-voltage release	/	
AX+SHT	Auxiliary contact and shunt release		
AX+UVT	Auxiliary contact and under-voltage release	/	
AX+AL+SHT	Auxiliary contact, alarm contact and shunt release		
AX+AL+UVT	Auxiliary contact, alarm contact and under-voltage release	/	

**Note:** 1.If there is need to learn about the instructions of installation of accessories of a 4 poles circuit breaker, please contact with the manufacturer;  
 2.If there is need for a UVT, a voltage module for the UVT is needed firstly(no voltage module is needed for a SHT).  
 3.The standard installation of a SHT is the left pole installation, UVT is the right pole installation, please note if there is any special request.  
 4.AL module of a VM3-630 product is special supply for the right pole installation, please contact with the manufacturer

## Control accessories

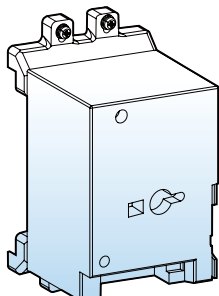

Motor-operated mechanism (CD2)

## Motor-operated mechanism (CD2)

Motor-operated mechanism which consists of an energy storage spring, an opening coil and a closing coil is used to control a circuit breaker from a distance. And a CD2 Motor-operated mechanism has the following features: CD2 type electric operating mechanism has

- The operation mode, manual or automatic mode, can be chosen.
- Hand drive handle is in front of a face cover.

The wiring diagram of a CD2 motor-operated mechanism is shown as following (internal accessories are indicated in the dotted square)

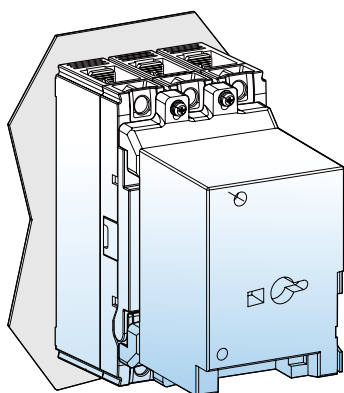
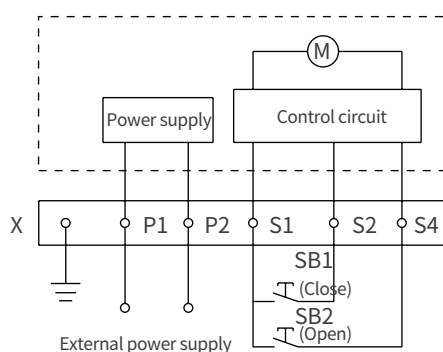

## Manual operation

- The internal power supply is automatically closed, if the switch is operated to "manual" position.
- Put the handle into the slot in the front of an electric operating mechanism and then turn in a clockwise direction.
- Do not turn it in a counterclockwise direction.

## Electric operation

- Auto connection
- Operating frequency should be no more than 3 times per minute.
- Using ON/OFF switches in the frequency range.
- Please do not input ON/OFF signal during automatic operation.
- Under-voltage release accessory(UVT) need to be applied a rated voltage before electric operation, if a Under-voltage release accessory(UVT) is mounted in a circuit breaker.

Motor-operated mechanism appearance

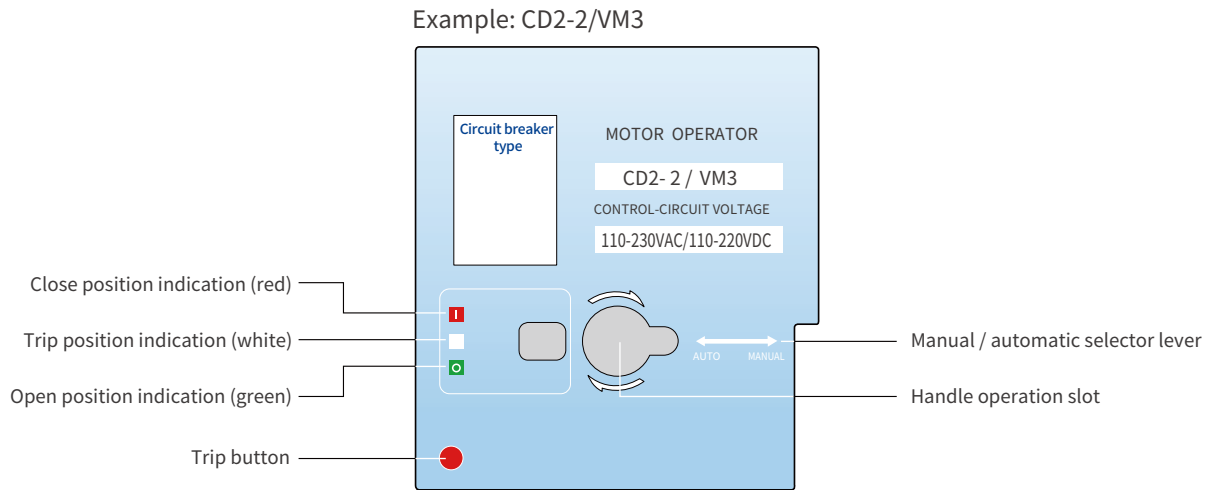

Acting Current, Motor Power and Longevity of CD2 type Power-driven Operating Mechanism

Equipped with circuit breaker type	Electric operating mechanism type	Control voltage	Starting current(A)	Response time(ms)		Power consumption	Durability
				Closed	Disconnect		
VM3-630 (Thermal-magnetic)	CD2-3	AC 110V/230V/400V DC 110V/220V/24V	≤ 0.5	500	350	14	10000

**Note:** After the circuit breaker trips, power-driven operating mechanism has to make the circuit breaker recamped, then it can be turned on.

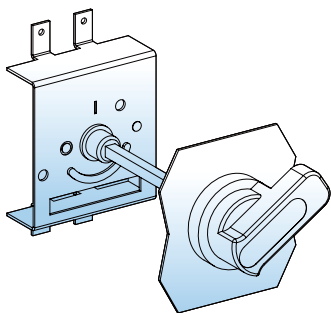

### Rotary handle operator (CS1、CS2、CS3) \*

With the unique design and transmission mechanism, the rotary handle operator can make the circuit breaker open, close and lock the tripping part by turning the handle.

**Note:** Rotary handle operator CS1、CS2、CS3 types details as P2-21 show

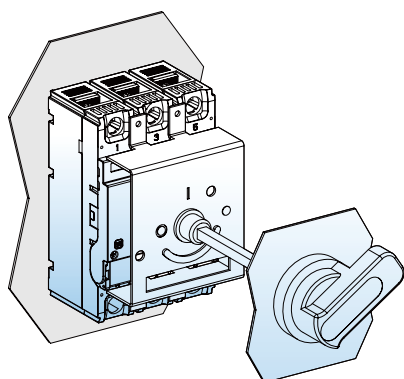

### CS series rotary handle operator has the following features:

- Equipped with circular and square rotary operating handles.
- The panel sheet of the cabinet cannot be opened when the circuit breaker is on (i.e interlock with the door).
- The handle can related supporting drawers, and interlock with the drawer unit.
- If fault of the operation handle occurs during its closing state, the panel sheet can be opened by operating the emergency reliever.
- Extended rotary handle can be used and the length of the extension handle is determined according to the distance between the rotary handle and the door. The shortest and the longest are 150mm and 500mm

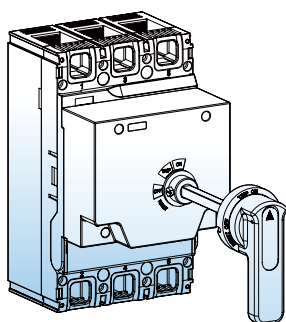

### Classification

The rotary handle mechanism contains central type and eccentric type.  
The rotary handle contains R type(circular) and F type(square).

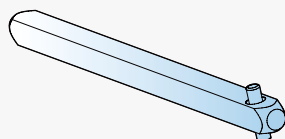

Connecting rod

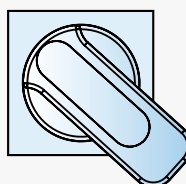

F-type square handle

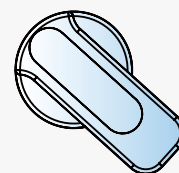

R-type round handle

## Insulation accessories

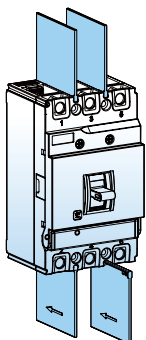

### Phase separator

- The insulation strength can be enhanced by phase separators.
- It can be installed from a slot of a switch after the switch is mounted.
- It can be used with all the other accessories except long and short covers.

## Thermal magnetic protection operating characteristic curve

Current-Temperature Characteristics

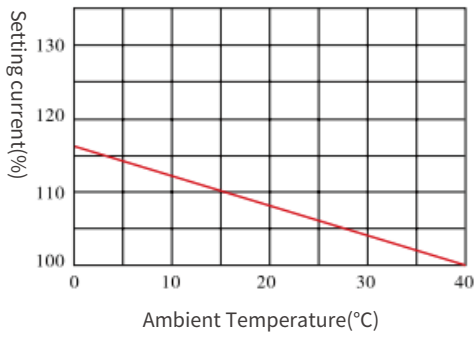

VM3-250 Time/Current Characteristic curve

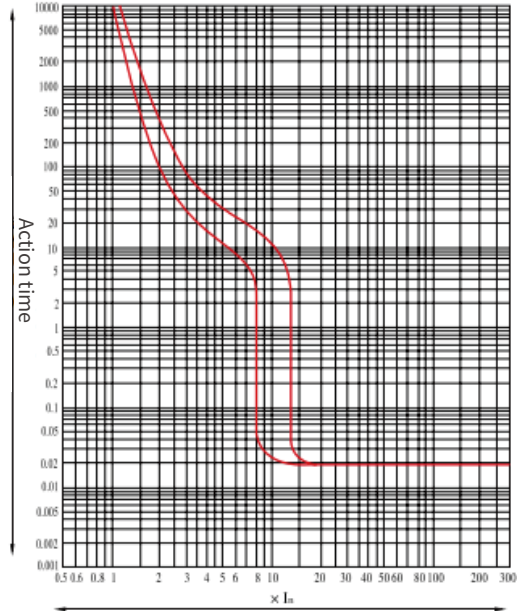

VM3-630 Time/Current Characteristic curve

Current-Temperature Characteristics

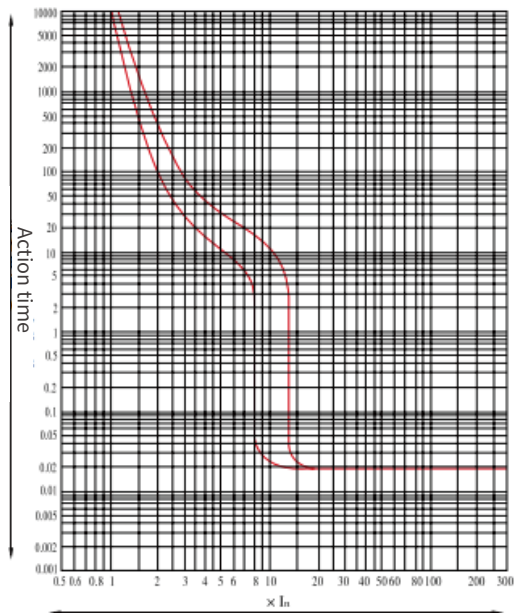
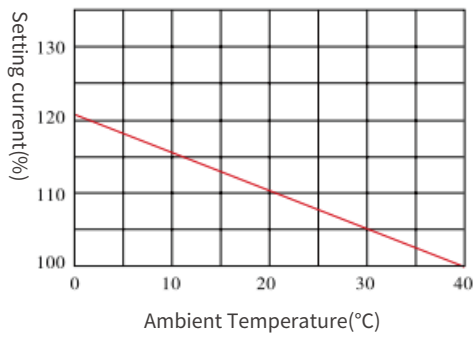

## VM3-250HU series dimensions and installation

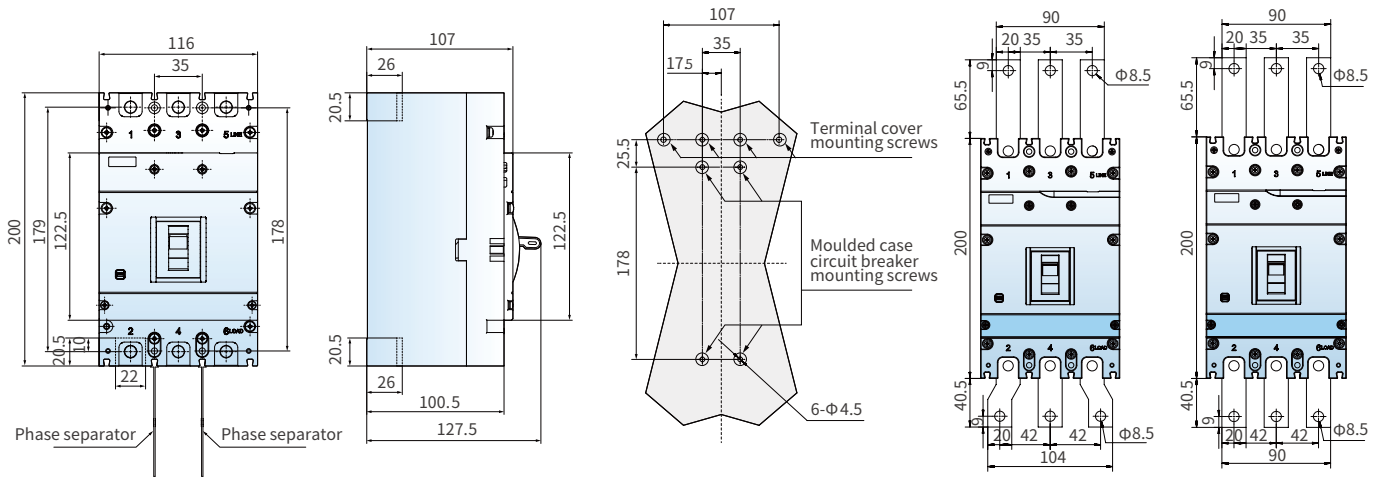

**Note:** Ensure the circuit breaker is fixed to the plate or the beam of the cabinet

## VM3-250HU series dimensions with terminal cover

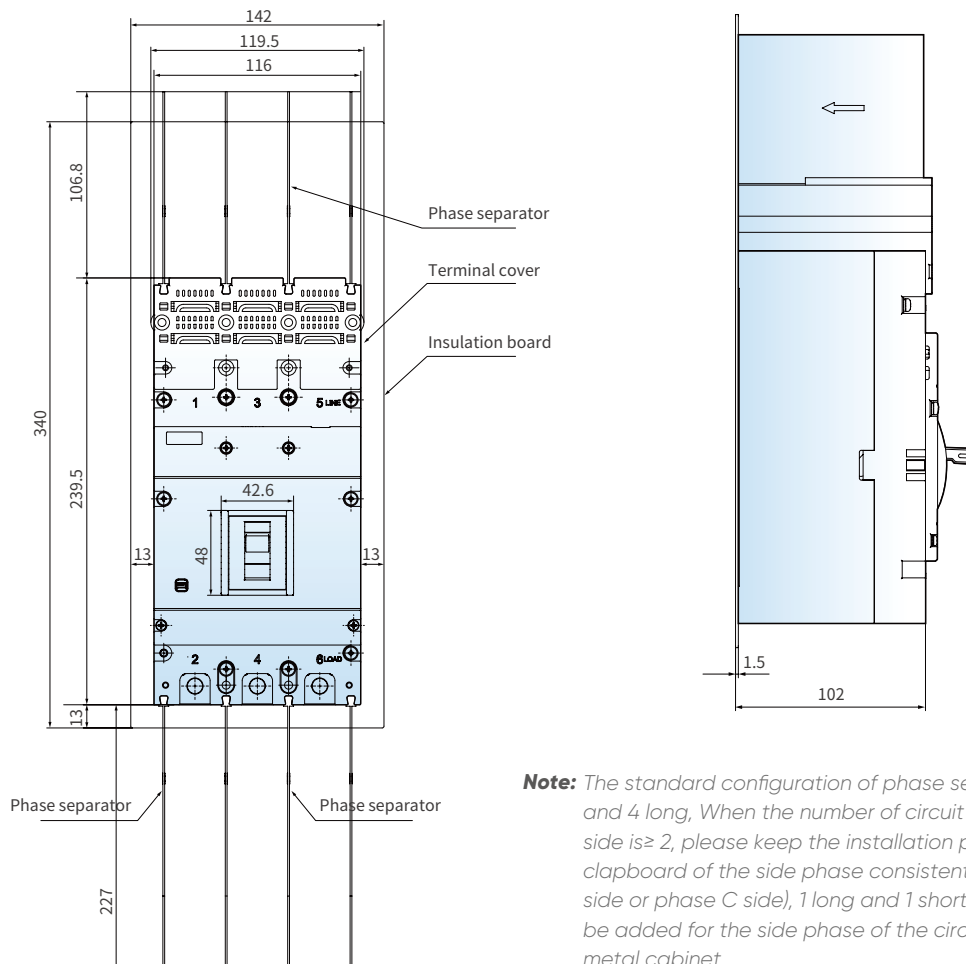

**Note:** The standard configuration of phase separators is 8, and 4 short and 4 long. When the number of circuit breakers installed side by side is  $\geq 2$ , please keep the installation position of the interphase clapboard of the side phase consistent (all installed on phase A side or phase C side), 1 long and 1 short (phase separator) should be added for the side phase of the circuit breaker close to the metal cabinet.

## VM3-630HU series dimensions and installation

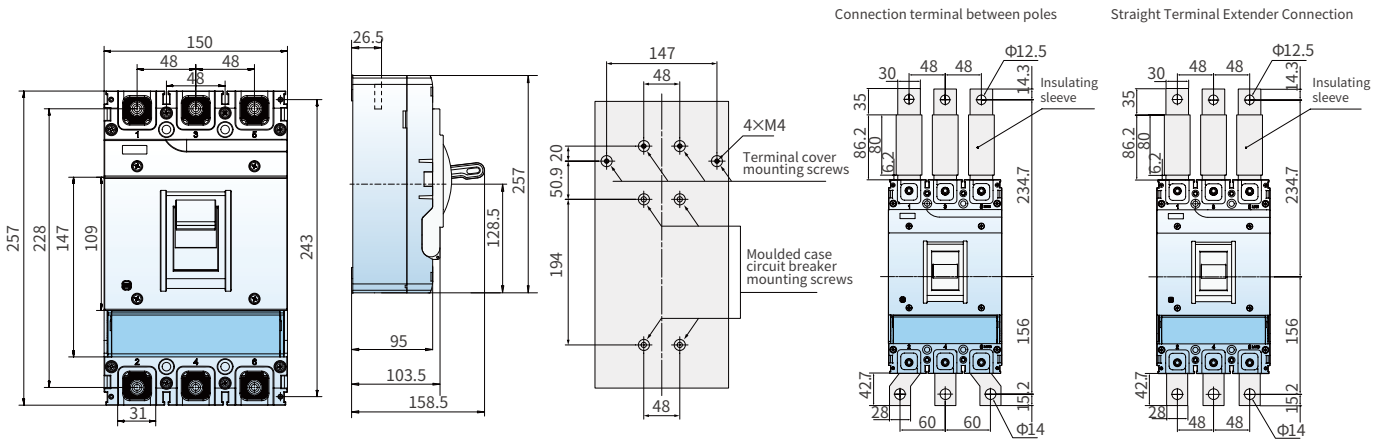

**Note:** Ensure the circuit breaker is fixed to the plate or the beam of the cabinet

- Note: 1.** This diagram removes the terminal cover, phase separator and insulation board.
- 2.** This terminal expander is not standard matching and needs to be matched.
- 3.** Sides 1,3,5 terminal expander can only be matched with straight bar; 2,4,6 terminal expander can choose both straight bar or extend bent bar.

## VM3-630HU series dimensions with terminalcover

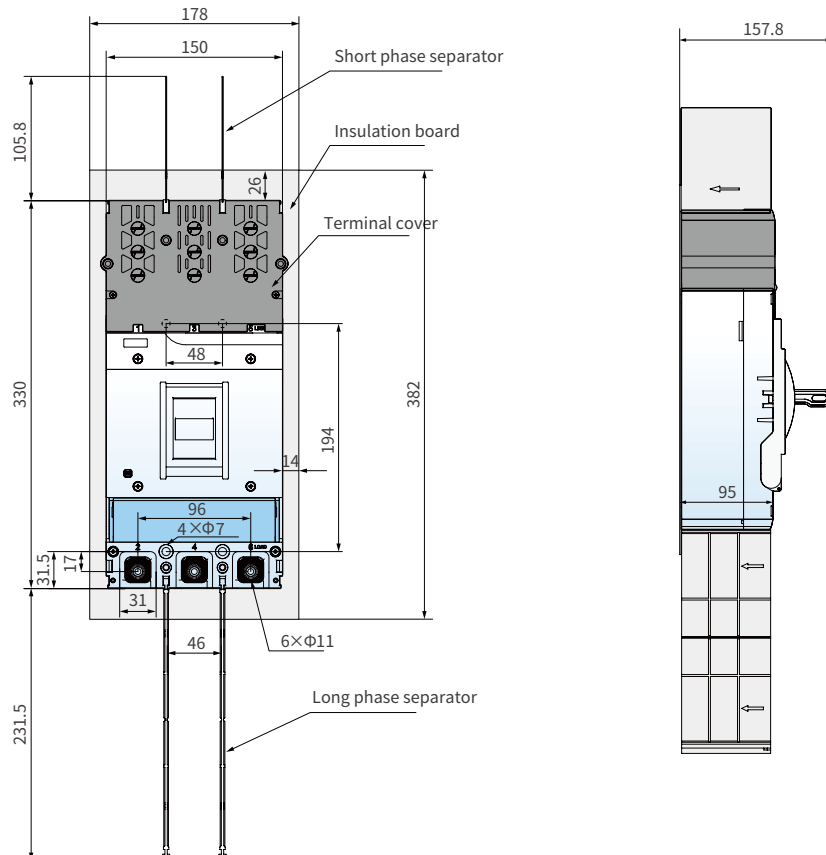

## Safety distance and installation diagram for VM3-250HU

The minimum spacing between adjacent circuit breakers

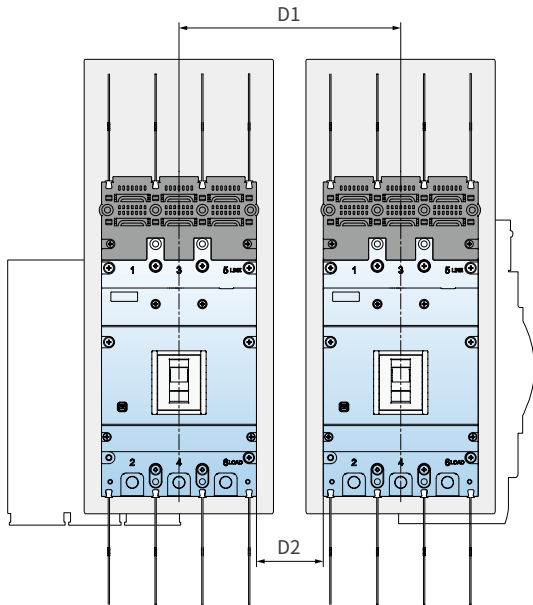

The minimum spacing of the top, baseplate and side plate of the circuit breaker

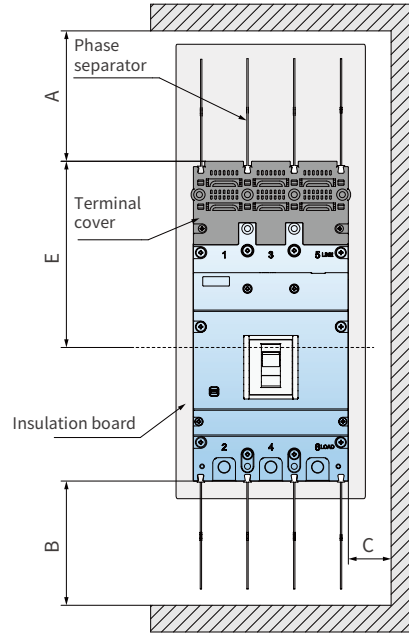

The minimum insulation length of wiring bar when it is front panel connection

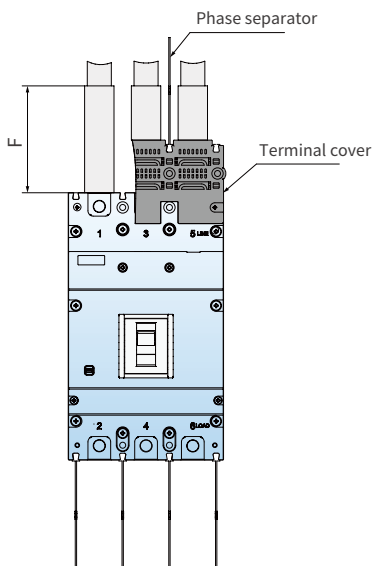

The minimum spacing between the circuit breaker and front panel

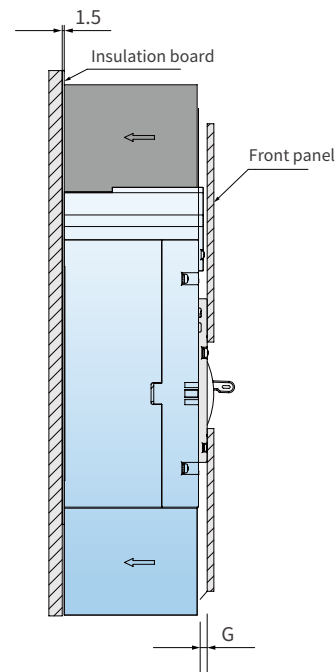

Model	Distance (mm)								
	A	B	C	D1	D2	E	F	G	
								Insulation board	Metal board
VM3-250HU	150	228	30	146	30	139.5	350	0	30

**Note:** When users use, terminal cover and phase separator should be assembled on terminals 1,3 and 5 of circuit breaker according to graphics. Phase separator should be assembled on terminals 2,4 and 6 of circuit breaker according to graphics. Insulation board is installed between circuit breaker and metal installation board.

## Safety distance and installation diagram for VM3-630HU

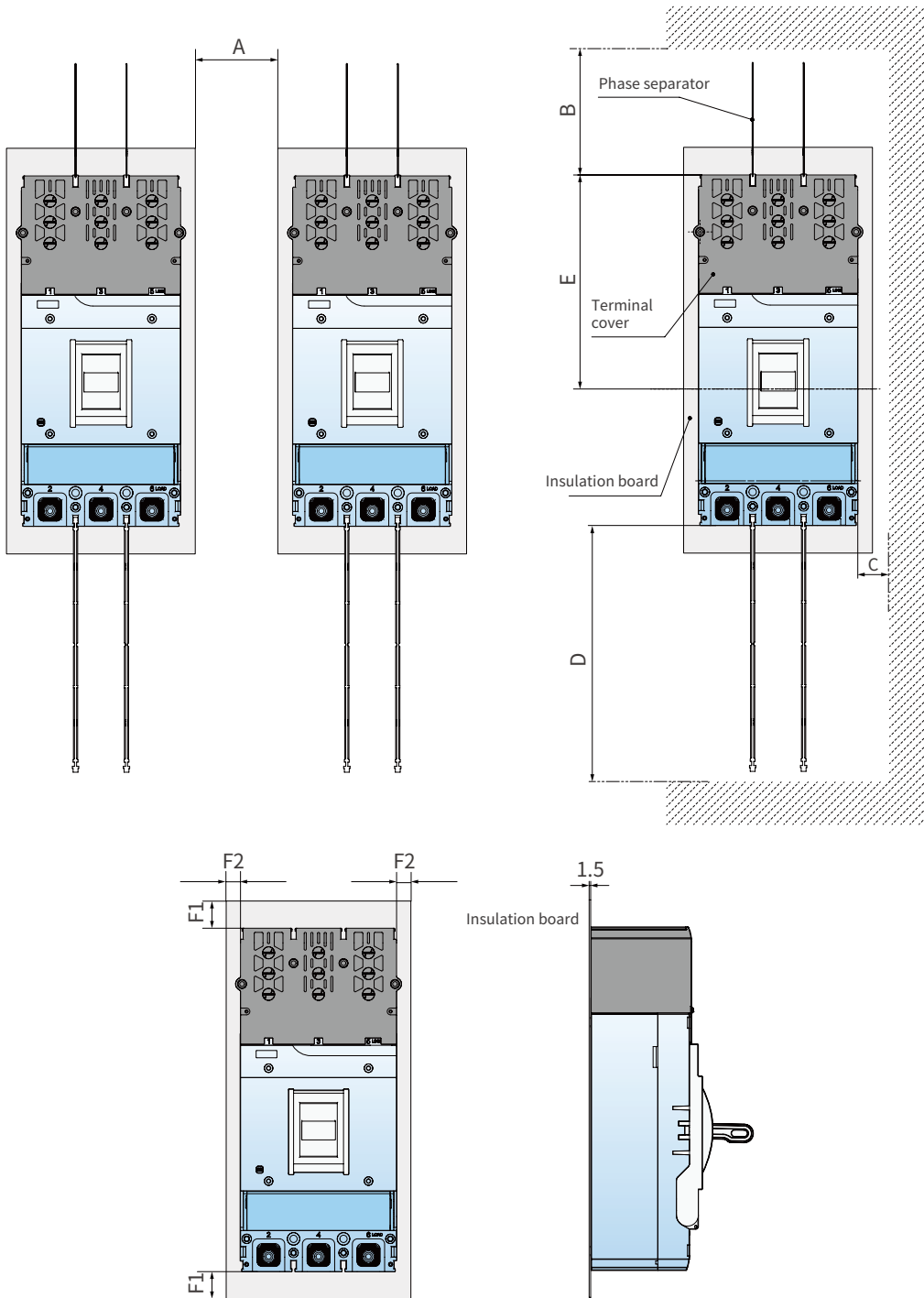

Model	A	B	C	D	E	F1	F2
VM3-630HU	30	150	30	180	201.5	26	14

**Note:** When users use, terminals 1,3 and 5 of the circuit breaker connect to transformer side and install terminal cover and phase separator according to graphics. Terminals 2,4 and 6 connect to inverter side and install phase separator according to graphics. Insulation board is installed between circuit breaker and metal installation board.

## Motor-operated mechanism

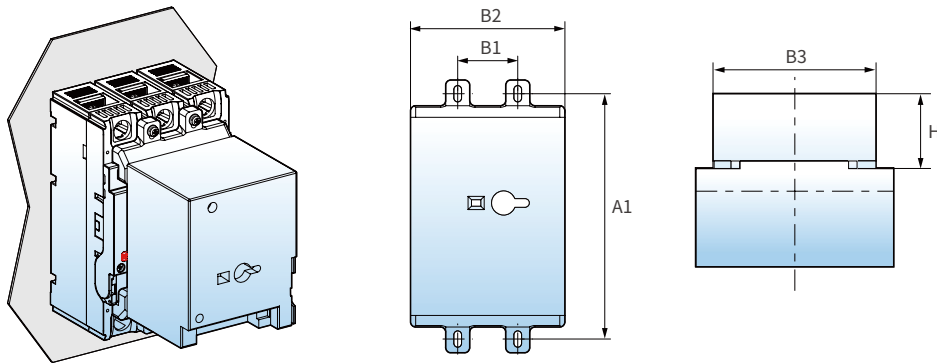

Motor-operated mechanism dimension table

Circuit breaker type	Motor operator model	A1	B1	B2	B3	H
VM3-630 (Thermal-magnetic)	CD2-3	194	48	129	175	156

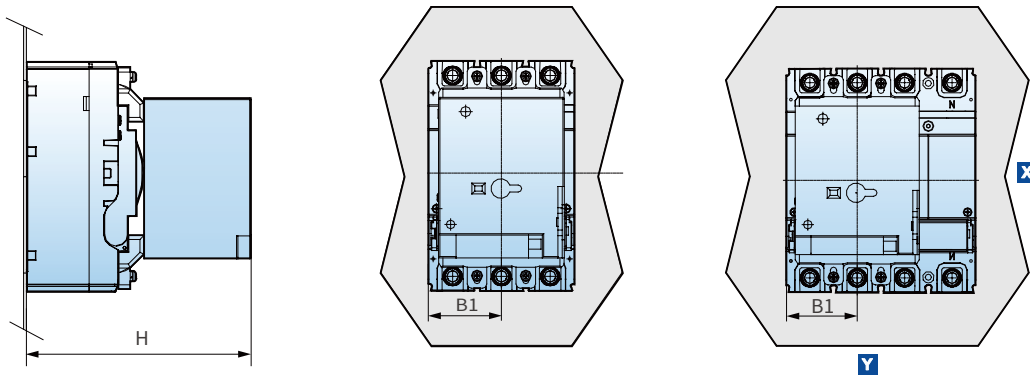

Model	B1	H
VM3-630 (Thermal-magnetic)	75	250.5

## Extended rotary handle dimension

### ■ Centric

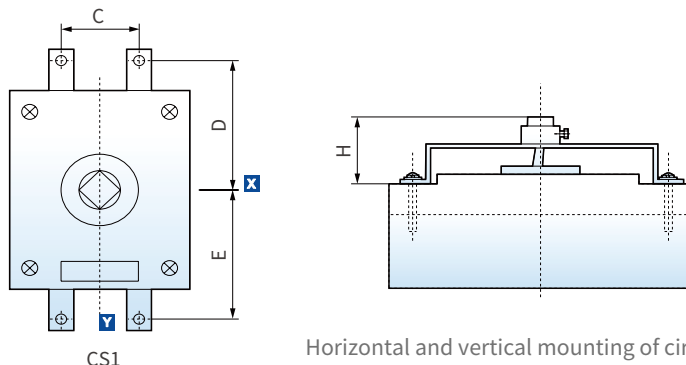

Horizontal and vertical mounting of circuit breaker

Centric size table

Model	Circuit breaker type	C	D	E	H	Remark
CS1-3	VM3-630 (Thermal-magnetic)	48	97	97	87	Used for vertical or horizontal installation of circuit breakers (centric trepanning)

### ■ Eccentric type

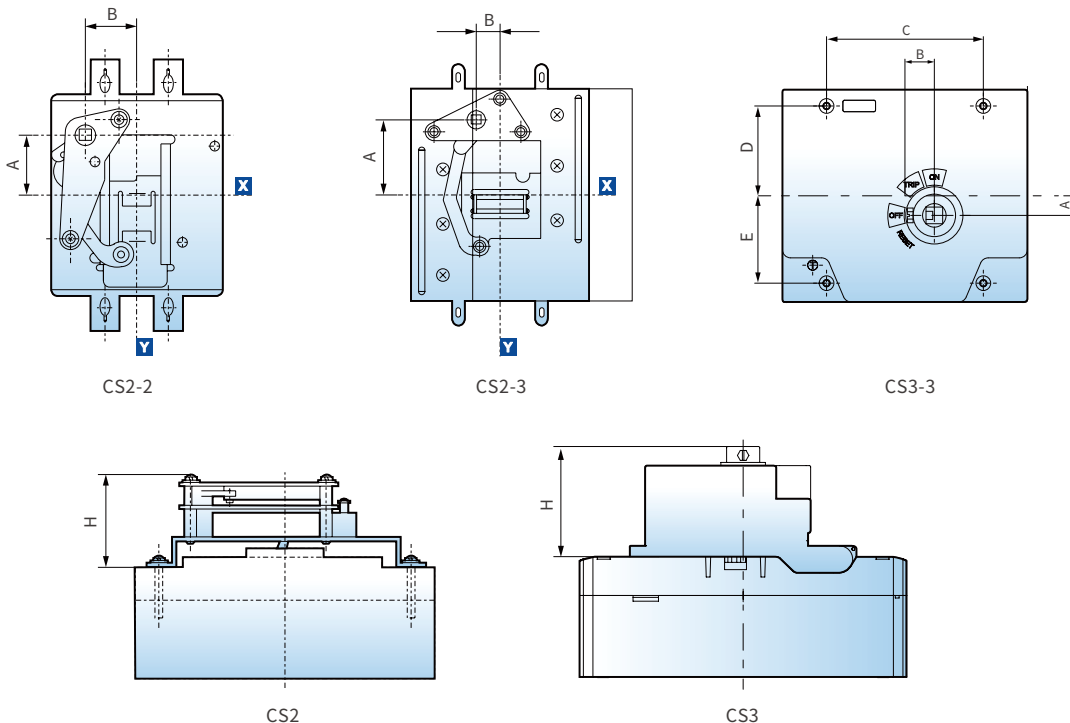

Eccentric size table

Model	Circuit breaker type	A	B	H	D	E	Remark
CS2-3	VM3-630 (Thermal-magnetic)	68	15	59	/	/	Used for vertical or horizontal installation of circuit breakers (eccentric trepanning)
CS3-3	VM3-630 (Thermal-magnetic)	12	18	86.5	55	53.5	Used for vertical or horizontal installation of circuit breakers (eccentric trepanning)

## Extended rotary handle installation

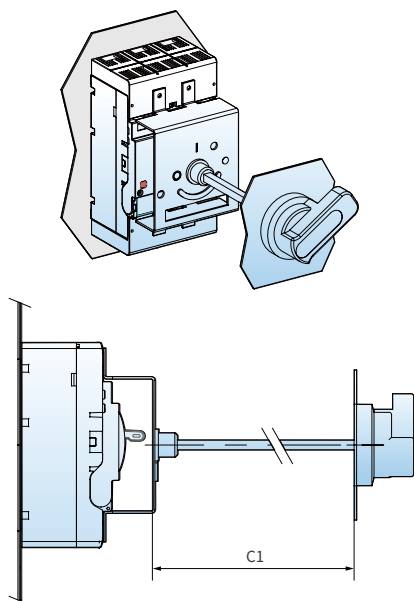

Circuit breaker model	C1	
	min	max
VM3-630	150	300

## Extended rotary handle installation

### Size and door sheet trepanning

F-type (F1 type used for VM3-250, F2 type used for VM3-630)

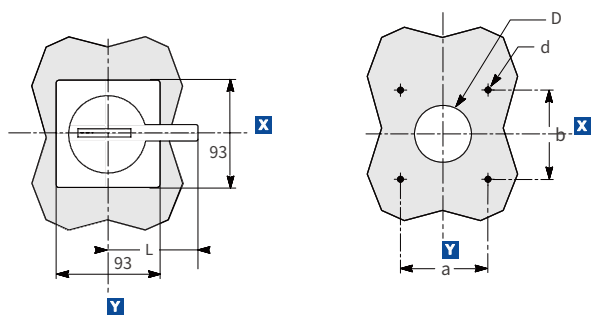

### F-type

F type handle mounting dimensions

Handle specifications	F1	F2
D	φ 42	φ 42
d	φ 4.5	φ 4.5
a	65	65
b	65	65
L	65	95

R-type (R1 type used for VM3-250, R2 type used for VM3-630)

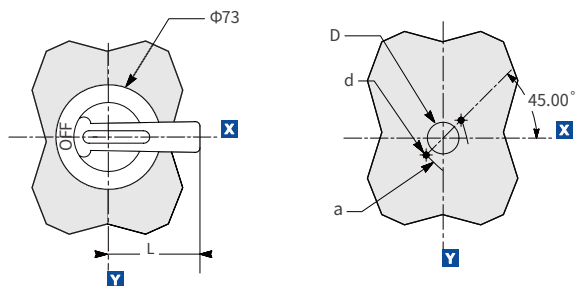

### R-type

R type handle mounting dimensions

Handle specifications	R1	R2
D	φ 34	φ 34
d	φ 5.5	φ 5.5
a	φ 53	φ 53
L	65	95

- Note:**
1. The standard configuration of CS1 and CS2 type rotating handle is R type and the length of square shaft is 200mm which connects rotary handle and the operating mechanism. Please specify if you have special requirement.
  2. For three pole and four pole circuit breakers, rotating handles have the same parameters.
  3. VM3-250 hand aperture dimensions refers to F1, R1 and VM3-630 aperture dimensions refers to F2, R2.

# VM5

Molded Case Circuit Breaker





- Tailored for solar energy and wind power
- Working voltage up to 1000V
- With ultra-high breaking capacity
- With excellent anti damp heat and dew solidification capabilities
- Strong ability to adapt to alternating changes in high and low temperatures
- With thermal and magnetic adjustability

## Ambient conditions

### Operating ambient temperature/storage temperature

- Operating environment temperature: -40 °C~+70 °C, with an average value of no more than +35 °C within 24 hours
- Storage temperature: -40 °C~+75 °C

### Altitude conditions

- Altitude of installation site  $\leq$  2000m (Over 2000 meters need capacity reduction for using)

### Pollution level

- Level 3

### Protection level



- Product protection level: IP20

### Installation Category

- Class II (load) and Class III (distribution and control)

### Installation Environment

- The product is installed in a medium without explosion risk, and the medium is not sufficient to corrode metal, there is no gas that damages the insulation layer of the product, there is no conductive dust, and it should be avoided from being used in places invaded by rain and snow

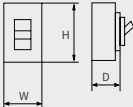
Type		VM5-320HU	VM5-630HU		
					
Rated current	A	63, 80, 100, 125, 140, 160, 180, 200, 225, 250, 320	315, 350, 400, 500, 630		
Pole number		3			
Rated operating voltage	AC50~60Hz (V)	800, 1000			
Rated insulation voltage	V	1000			
Rated impulse withstand voltage Uimp	kV	8			
Breaking capacity		L	M	L	M
Ultimate short-circuit breaking(Icu)	AC800V	30	50	50	50
	AC1000V	15	30	15	18
Service short-circuit breaking(Ics)	AC800V	30	50	36.5	50
	AC1000V	12	18	15	18
Mechanical durability	Times	12000		8000	
Electrical durability	AC800V	Times		1000	
	AC1000V	Times		1000	
Outline dimension (mm) (H × W × D)		185 × 112.5 × 114.5		255 × 140 × 122.5	
Isolation function		Have isolation function			
Optional trip unit	TMD	Thermally adjustable (0.7~1.0) Magnetic adjustable (5~10)			
	TAL	Thermally adjustable (0.7~1.0) Magnetic fixation (10In)			

**Note:**

VM5-320: 63A is thermally adjustable magnetic fixation, 80~320A is thermo-magnetic adjustable;  
 VM5-630: Only thermo-magnetic adjustable;

# Selection Guide

# VOZWEI

<b>VM5</b>	–	<b>320</b>	<b>HU</b>	<b>M</b>	<b>320</b>	/	<b>TMD</b>	/	<b>3</b>	/	<b>AX/SHT</b>
1		2	3	4	5		6		7		8

SN	Name	Specification, type code	
1	Design code	VM5: Design code	
2	Frame rating	320: 320A 630: 630A	
3	High voltage	HU: High voltage	
4	Breaking capacity	L, M	
5	Rated current	63A~630A	
6	Protection unit type	TAL: Thermal protection unit (power distribution protection, 63A) TMD: Thermal magnetic adjustable unit (For power distribution protection, 80~630A)	
7	Number of poles	3P	
8	Accessories (separated with"/" between different accessories)	Connection accessories	Empty: Fixed type wiring in front of the board
		Electrical accessories	AL: Alarm contact AX: Auxiliary contact SHT: Shunt release
		Expansion accessories	K6: Phase separator K11: Insulating mounting plate CD3: Motor operator CS1: Rotary handle operator

## \* Electrical accessories

Accessories	Voltage				
SHT Shunt release	AC230V	AC400V	DC220V	AC/DC110V	DC24V

If the accessory voltage and voltage control loop is inconsistent, please use indicate the accessory voltage after accessory.

### Example

**VM5-630HUM630/TMD/3/AX/SHT(AC230V)**

Meaning: VM5 series circuit breaker; the frame level is 630; 3 poles; rated current is 630A; fixed rear connection; accessory contains auxiliary contact and shunt release with voltage (AC230V).

## TMD/TAL: Data sheet of protection characteristics

Rated current	Inverse time acting characteristic (Ambient air temperature +40°C)		Instantaneous acting current
	1.05I <sub>n</sub> (Cold state) Not acting time	1.3I <sub>n</sub> (Cold state) Not acting time	
I <sub>n</sub> ≤ 63	≥ 1h	< 1h	TMD: 5~10 ± 20% TAL: 10I <sub>n</sub> ± 20%
63 < I <sub>n</sub> ≤ 800	≥ 2h	< 2h	

## Derated coefficient of rated current

Circuit Breaker Model	+40°C	+45°C	+50°C	+55°C	+60°C	+65°C	+70°C
VM5-320HU	1.0 I <sub>r</sub>	0.98 I <sub>r</sub>	0.96 I <sub>r</sub>	0.94 I <sub>r</sub>	0.92 I <sub>r</sub>	0.91 I <sub>r</sub>	0.88 I <sub>r</sub>
VM5-630HU	1.0 I <sub>r</sub>	0.97 I <sub>r</sub>	0.95 I <sub>r</sub>	0.93 I <sub>r</sub>	0.91 I <sub>r</sub>	0.89 I <sub>r</sub>	0.87 I <sub>r</sub>

## Derated coefficient of high altitude of VM5 series MCCB

Item	Parameter						
Elevation	2000	2500	3000	3500	4000	4500	5000
Power frequency withstand voltage	3500	3500	3200	3000	2800	2750	2500
Isolation voltage	1250	1250	1250	1140	1140	1140	1140
Breaking capacity correction factor	1	1	0.9	0.85	0.8	0.75	0.7
Working current correction factor	1	1	0.98	0.97	0.96	0.95	0.94

## Sign interpretation

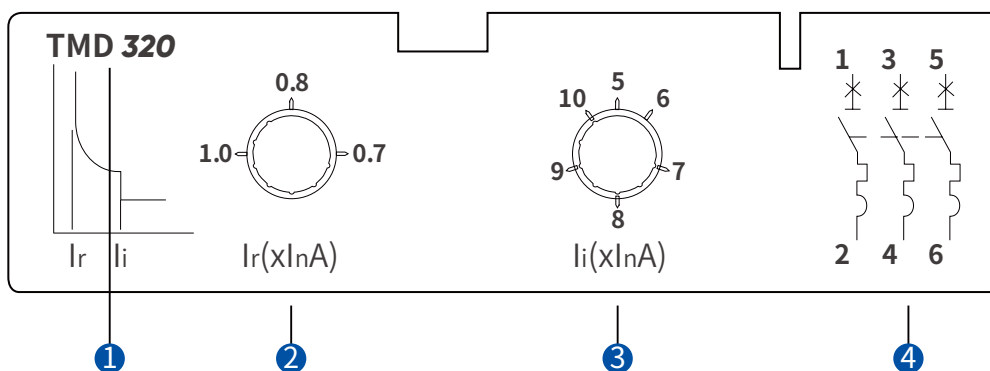

- ① Thermal magnetic adjustable unit  
Rated current is 320A
- ② Thermally adjustable
- ③ Magnetic adjustable
- ④ Wiring diagram

Electrical accessories

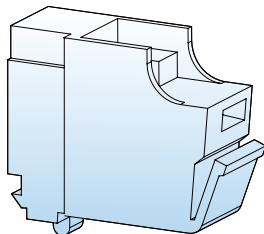

Alarm contact (AL)

Alarm contact (AL)

Function

The product outputs alarm signal when it is tripped by outer excitation signal due to overload, short circuit, undervoltage, or when the release button is pressed. This function is particularly useful in an automatic system, since that a fault signal can be sent to the designated place. And the fault signal will turn on due to an internal microswitch, when circuit breaker releases. But for normal opening or closing operations, it does not have any action.

Alarm contact operating characteristics

Circuit breaker status	Alarm contact status
The statuses of open and close	
The statuses of tripping	

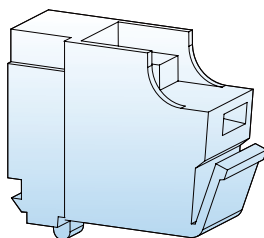

Auxiliary contact (AX)

Auxiliary contact (AX)

Function

Auxiliary switch is used for indication of remote "ON" and "OFF". Each switch contains two contacts, which share a common end of connection. The ON/OFF position depends on the state of main contact. When the circuit breaker is open, one of them is normally open, and the other is closed, or vice versa.

Auxiliary contact operating characteristics

Circuit breaker status	Auxiliary contact status
The statuses of open	
The statuses of close	

## Alarm contact, Auxiliary contact rated operational current

Classification	Rated current $I_{nm}$	Conventional thermal current $I_{th}(A)$	Rated working current $I_e(A)$	
			AC400V	DC220V
Auxiliary contact	$\leq 250$	3	0.3	0.15
	$400 \leq I_{nm} \leq 1000$	3	0.4	0.2
Alarm contact	$10 \leq I_{nm} \leq 1000$	-	AC220V/1.0A	0.15

## ON-OFF capacity of Alarm contact and Auxiliary contact under normal conditions

Utilization category	ON				OFF				Number of operation cycles	Number of operation cycles per minute	Power time
	$I/I_e$	$U/U_e$	$\cos\phi$	$T_{0.95}$	$I/I_e$	$U/U_e$	$\cos\phi$	$T_{0.95}$			
AC-14	10	1	0.7	-	1	1	0.7	-	6050	6	$\geq 0.05s$
DC-13	1	1	-	$6 \times Pe$	1	1	-	$6 \times Pe$			$\geq 0.05s$

## ON-OFF capacity of alarm contact and auxiliary contact under abnormal conditions

Utilization category	ON				OFF				Number of operation cycles	Number of operation cycles per minute	Power time
	$I/I_e$	$U/U_e$	$\cos\phi$	$T_{0.95}$	$I/I_e$	$U/U_e$	$\cos\phi$	$T_{0.95}$			
AC-14	6	1	0.7	-	1	1	0.7	-	-	-	$\geq 0.05s$
DC-13	1.1	1.1	-	$6 \times Pe$	1.1	1.1	-	$6 \times Pe$	10	6	$\geq 0.05s$

- Note:**
- $T_{0.95}=6Pe$  is an empirical formula in which the unit of "Pe" is watt and the unit of  $T_{0.95}$  is millisecond.
  - The number of operation of Auxiliary contact can equal to that of the circuit breaker, if the number of operation of circuit breaker is less than 6050.
  - The operation frequency and power-on time of an auxiliary contact are allowed to be the same as those of the main circuit.
  - If  $T_{0.95}$  is more than 0.05s, the power-on time is at least  $T_{0.95}$ .

## Shunt release (SHT)

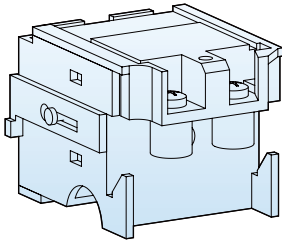

Shunt release (SHT)

### Function

Shunt release refers to the device which disconnect circuit breaker with current from a distance.

A shunt release can cut off the signal circuit automatically after tripping.

### Operating Characteristics

Voltage specification	AC50Hz: 110V 230V 400V DC: 24V 110V 220V
Operating characteristics	When the operation voltage is 70%~110% of the rated control voltage, the shunt release should trip the circuit breaker reliably.

### Connection diagram (internal accessories of a circuit breaker)

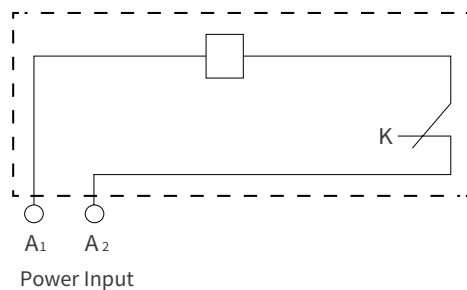

K is a microswitch closed contact of micro switch installed in series with the coil in shunt tripper, when the breaker is tripping, the switch is off by itself, when the breaker is closing, and then the switch is on.

## Combined mode of electrical accessories

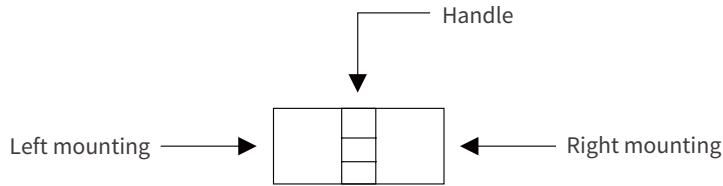

- Alarm contact
- Auxiliary contact
- Shunt release

Accessory code	Accessory name	Poles	Model	
			VM5-320HU	VM5-630HU
			3	3
AL	Alarm contact			
SHT	Shunt release			
AX	Auxiliary contact			
AX+SHT	Shunt release and alarm contact			
AL+SHT	Shunt release and alarm contact			
AL+AX	Auxiliary contact and alarm contact			
AX+AL+SHT	Shunt release, auxiliary contact and alarm contact			
	Without accessory			

## Control accessories

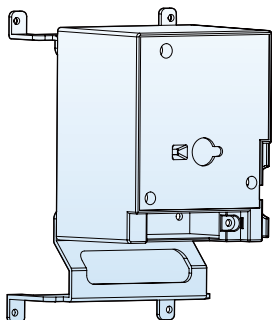

Motor operator mechanism (CD3)

## Motor operator mechanism (CD3)

Motor-operated mechanism which consists of an energy storage spring, an opening coil and a closing coil is used to control a circuit breaker from a distance. And a CD3 Motor-operated mechanism has the following features: CD3 type electric operating mechanism has

- The operation mode, manual or automatic mode, can be chosen.
- Hand drive handle is in front of a face cover.

The wiring diagram of a CD3 motor-operated mechanism is shown as following (internal accessories are indicated in the dotted square)

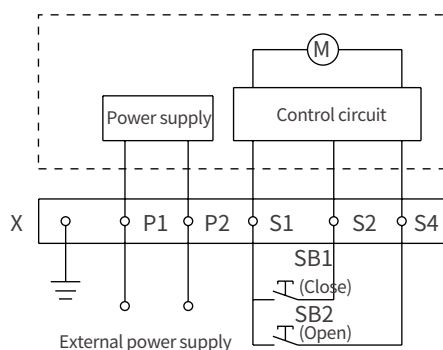

## Please pay attention to the following two points when wiring:

1. When the lead out distance of the electric control line is  $\leq 5$ m, a regular electronic line can be used as the controller, but it needs to be routed separately from the power line;
2. When the lead out distance of the electrical control line is  $\geq 5$ m or there is a possibility of strong electromagnetic interference in the surrounding environment, the control line should be shielded or connected to the control end (S1, S2, S4) of the electrical control through an intermediate relay installed near the electrical control, and the distance between the relay and the electrical control should not exceed 5m;

## Manual operation

- The internal power supply is automatically closed, if the switch is operated to "manual" position.
- Put the handle into the slot in the front of an electric operating mechanism and then turn in a clockwise direction.
- Do not turn it in a counterclockwise direction.

## Electric operation

- Auto connection
- Operating frequency should be no more than 3 times per minute.
- Using ON/OFF switches in the frequency range.
- Please do not input ON/OFF signal during automatic operation.
- UVT need to be applied a rated voltage before electric operation, if a UVT is mounted in a circuit breaker.

Motor-operator mechanism appearance

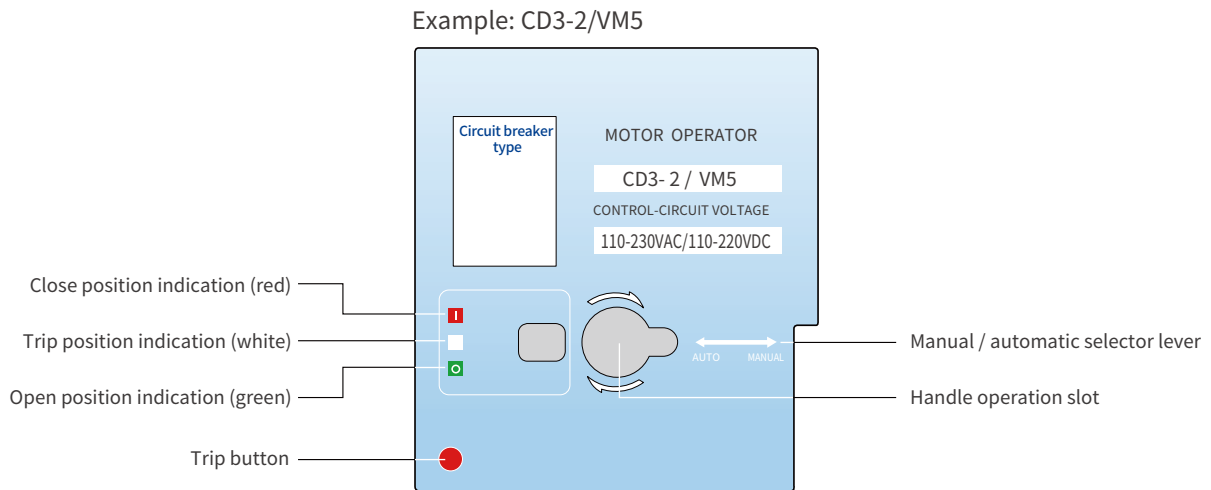

Acting Current, Motor Power and Longevity of CD3 type Power-driven Operating Mechanism

Equipped with circuit breaker type	Electric operating mechanism type	Control voltage	Starting current(A)	Response time(ms)		Power consumption	Durability
				Closed	Disconnect		
VM5-320HU	CD3-2	AC 110V/230V/400V DC 110V/220V/24V	$\leq 0.5$ $24VDC \leq 2$	$\leq 700$	$\leq 700$	14	10000
VM5-630HU	CD3-3	AC 110V/230V/400V DC 110V/220V/24V	$\leq 2$ $24VDC \leq 5$	$\leq 1000$	$\leq 1000$	35	5000

**Note:** After the circuit breaker trips, power-driven operating mechanism has to make the circuit breaker recamped, then it can be turned on.

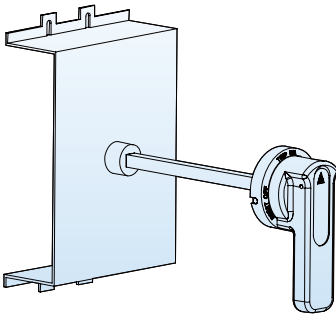

## Rotary handle operator (CS1)

With the unique design and transmission mechanism, the rotary handle operator can make the circuit breaker open, close and lock the tripping part by turning the handle.

### CS series rotary handle operator has the following features:

- Equipped with circular and square rotary operating handles.
- The panel sheet of the cabinet cannot be opened when the circuit breaker is on (i.e interlock with the door).
- The handle can related supporting drawers, and interlock with the drawer unit.
- If fault of the operation handle occurs during its closing state, the panel sheet can be opened by operating the emergency reliever.
- Extended rotary handle can be used and the length of the extension handle is determined according to the distance between the rotary handle and the door. The shortest and the longest are 150mm and 500mm

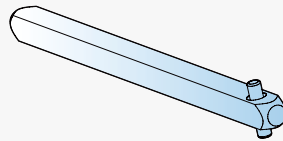

Connecting rod

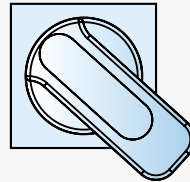

F-type square handle

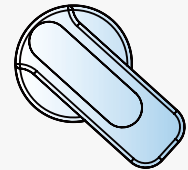

R-type round handle

## VM5-320HU series dimensions and installation

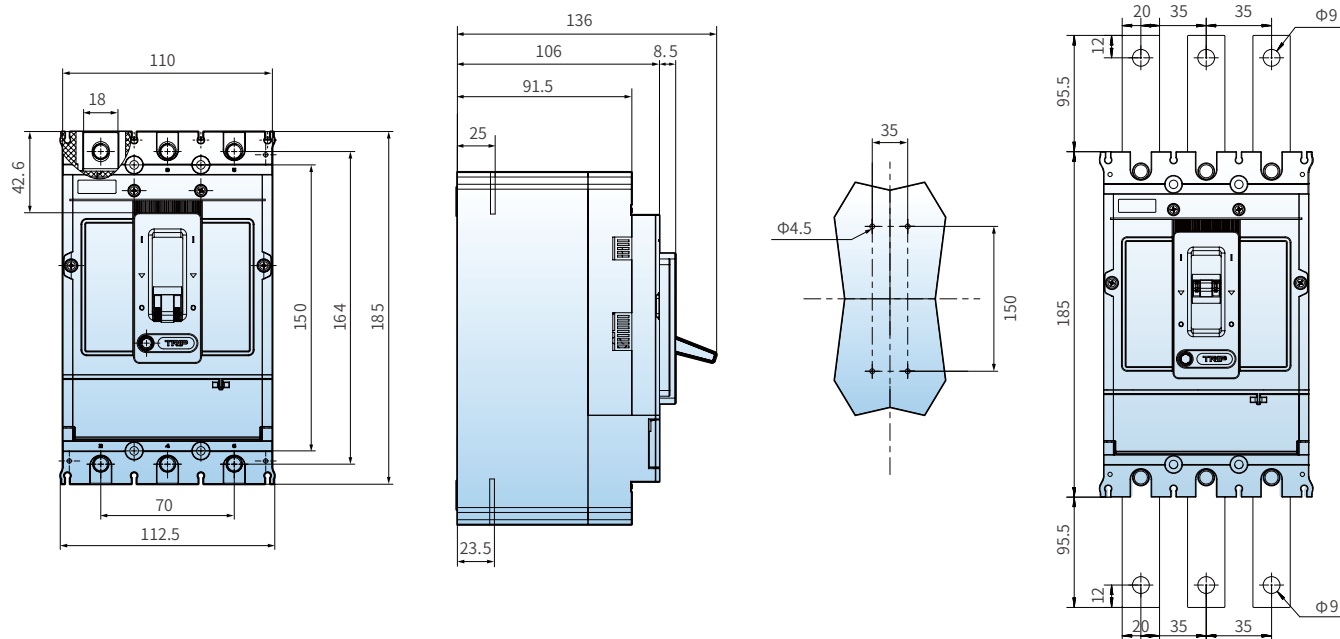

For toggling handle

## VM5-320HU series dimensions with terminal cover

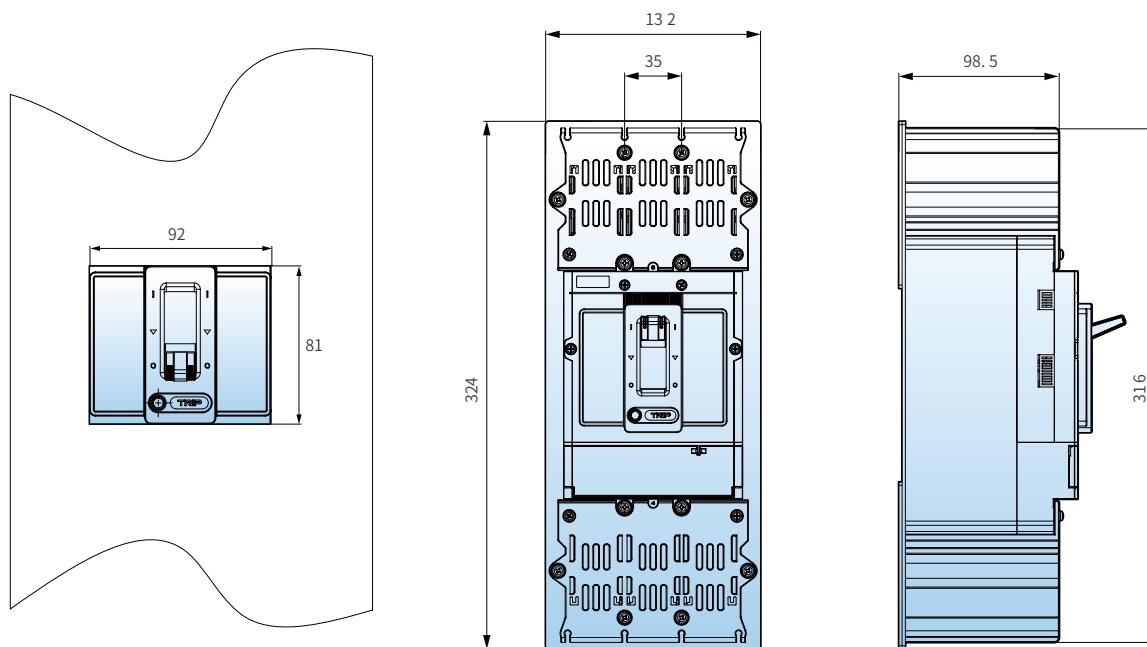

## VM5-630HU series dimensions and installation

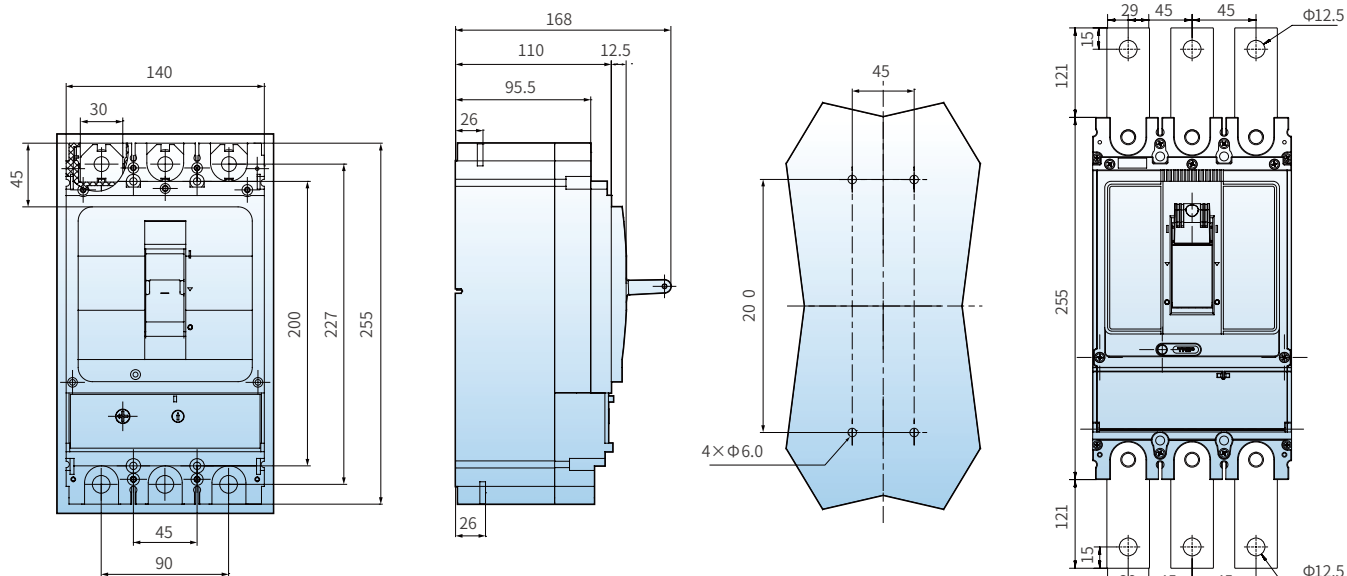

For toggling handle

## VM5-630HU series dimensions with terminal cover

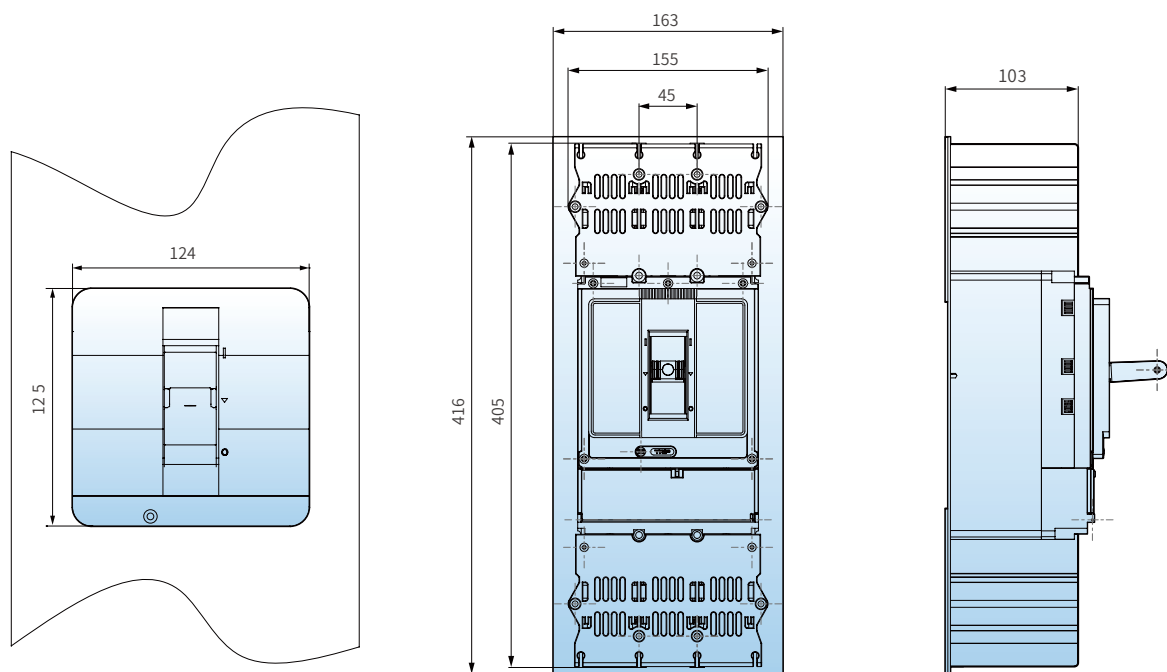

## Safety distance and installation diagram for VM5-320HU

Safety distance

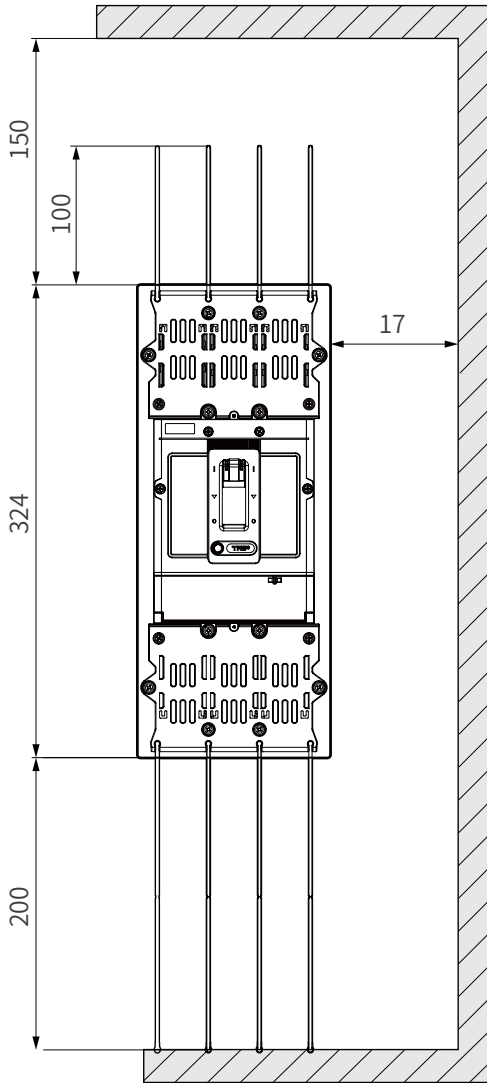

Minimum distance between two adjacent circuit breakers

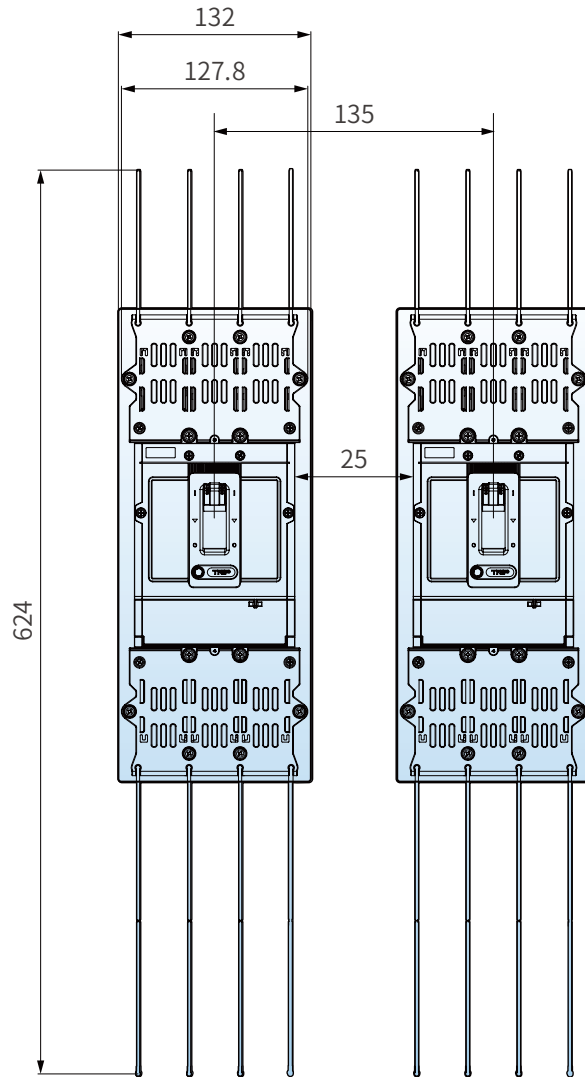

**Note:** There are 8 phase separators as standard, the top is short and the bottom is long, When the number of circuit breakers installed side by side is  $\geq 2$ , please keep the installation position of the interphase clapboard of the side phase consistent (all installed on phase A side or phase C side), 1 long and 1 short (phase separator) should be added for the side phase of the circuit breaker close to the metal cabinet.

Short terminal shield rear connected

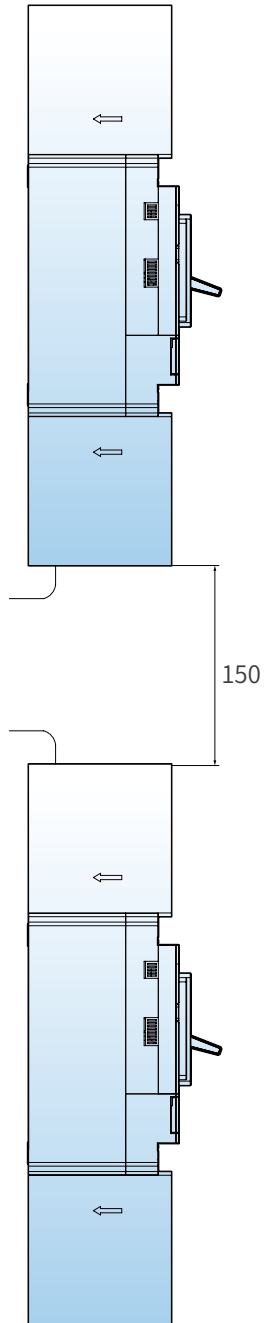

Minimum distance between circuit breaker and front panels

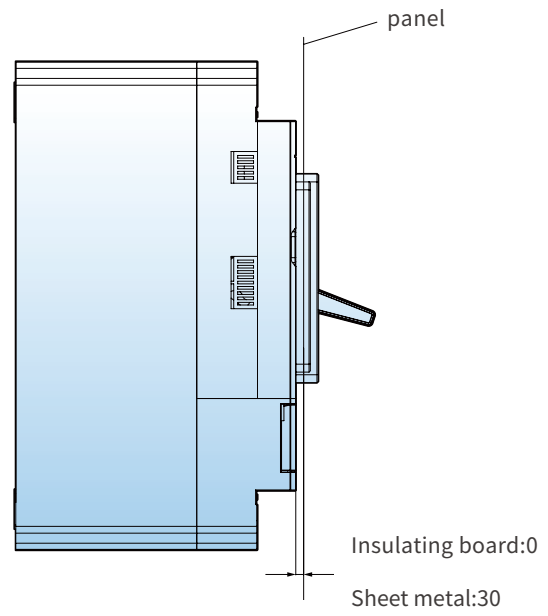

## Safety distance and installation diagram for VM5-630HU

Safety distance

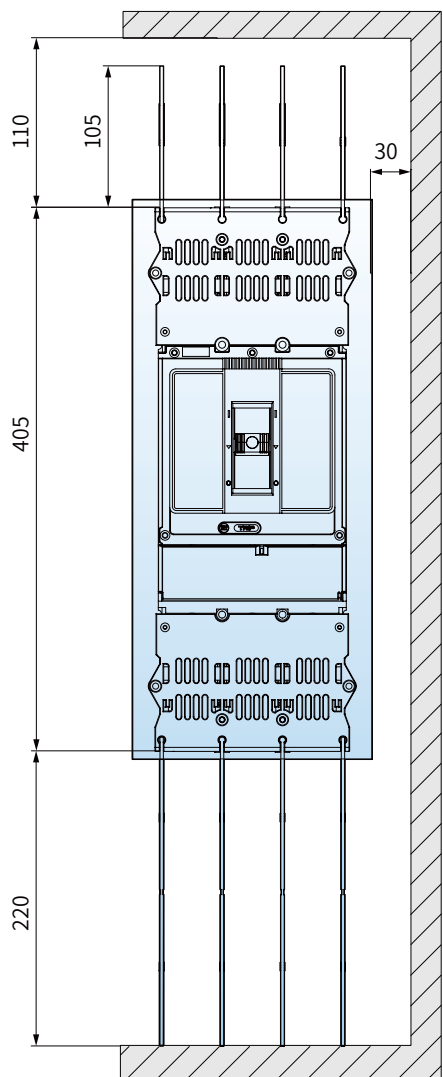

Minimum distance between two adjacent circuit breakers

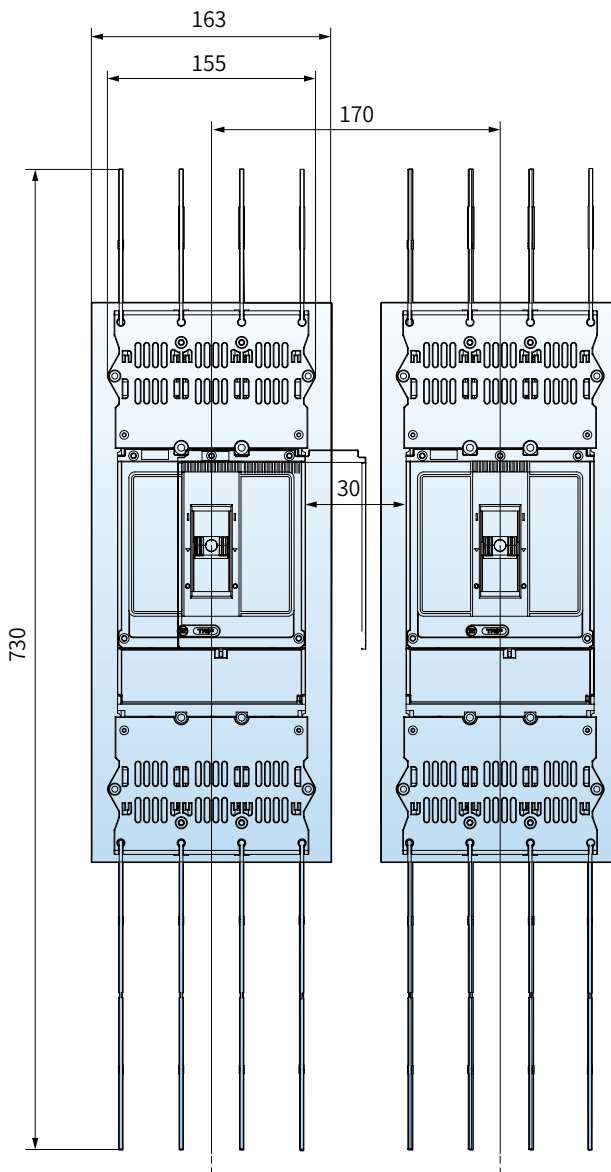

**Note:** There are 8 phase separators as standard, the top is short and the bottom is long, When the number of circuit breakers installed side by side is  $\geq 2$ , please keep the installation position of the interphase clapboard of the side phase consistent (all installed on phase A side or phase C side), 1 long and 1 short (phase separator) should be added for the side phase of the circuit breaker close to the metal cabinet.

Short terminal shield rear connected

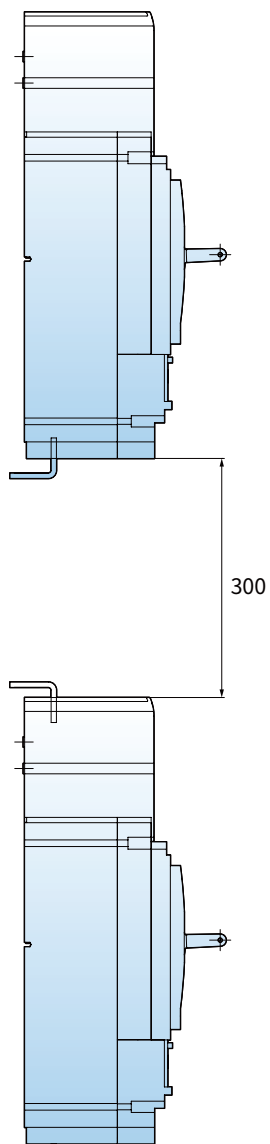

Minimum distance between circuit breaker and front panels

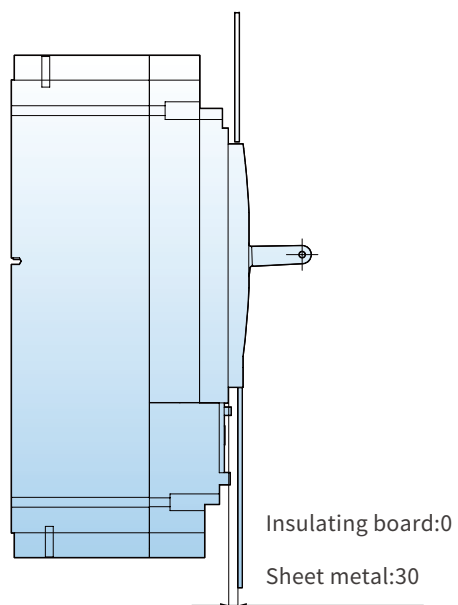

## Motor-operated mechanism

VM5-320HU

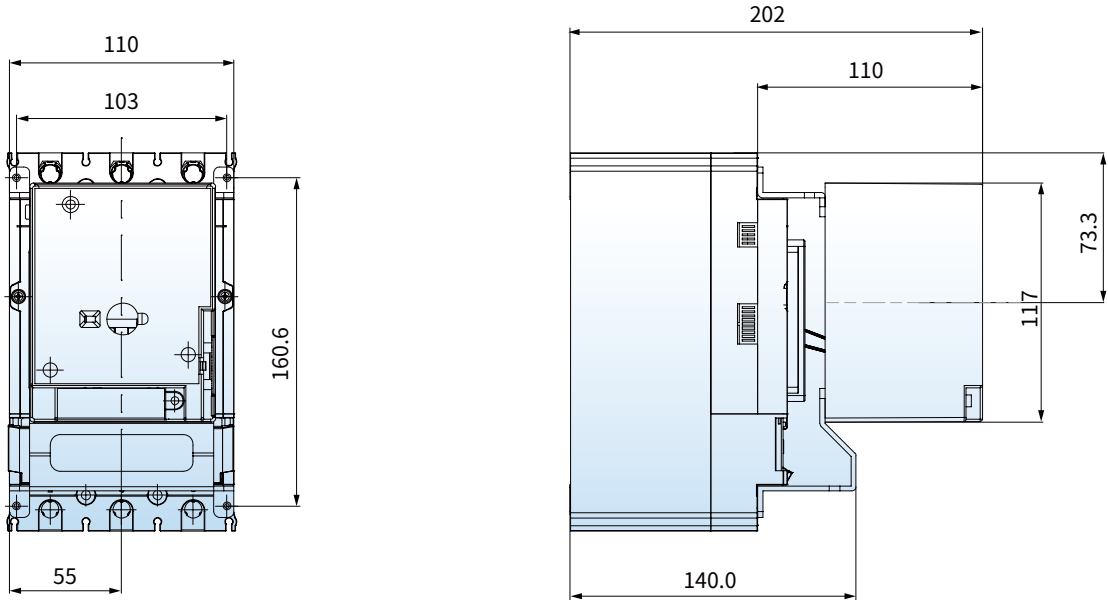

VM5-630HU

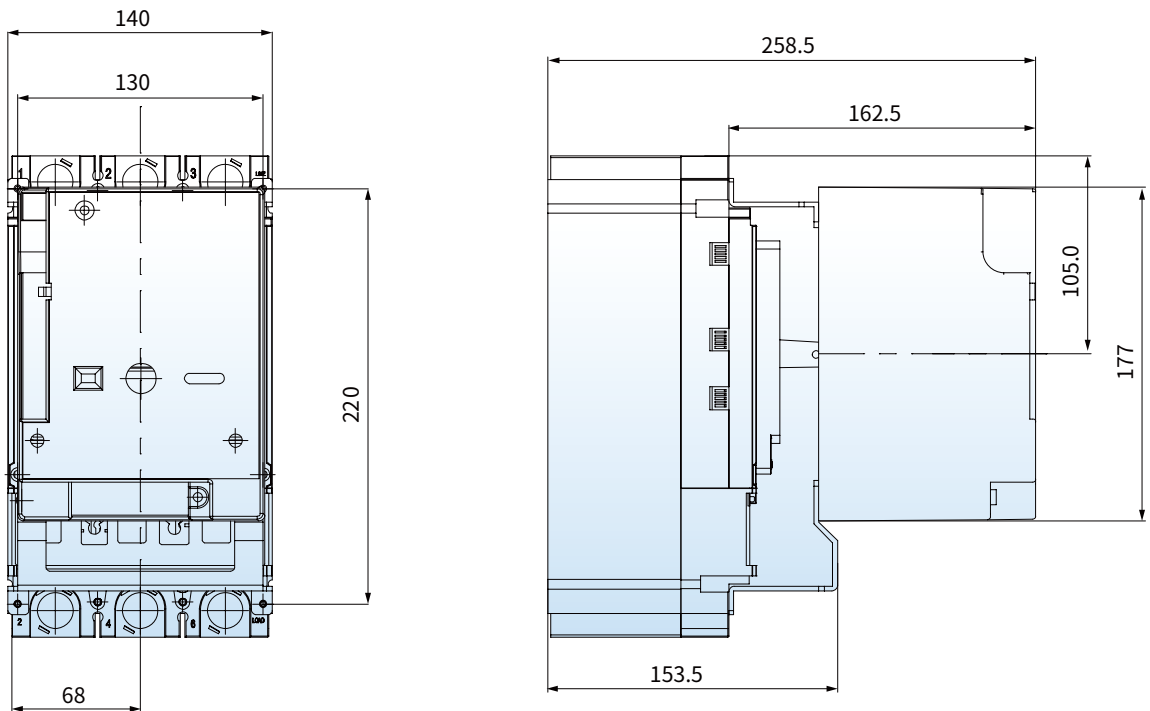

## Manual operator size

### VM5-320HU

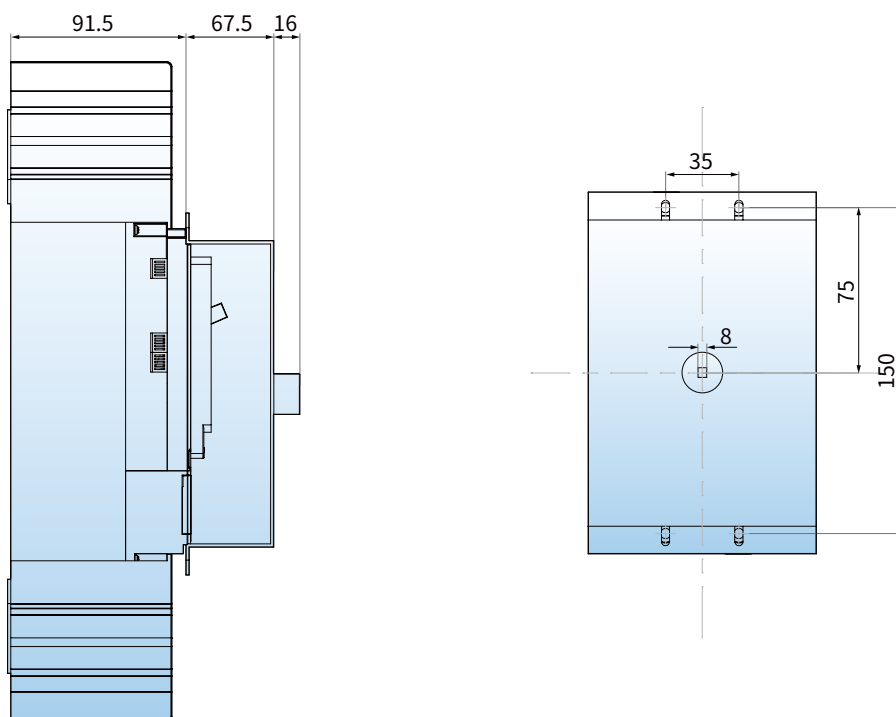

### VM5-630HU

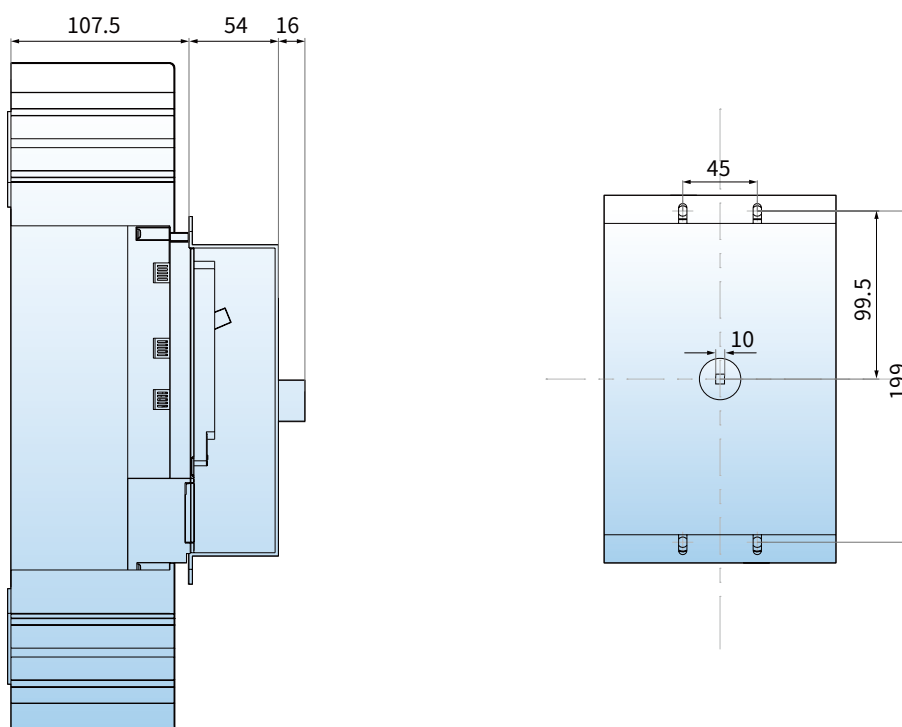

## Size and Connection

# VOZWEI

### Cross-sectional area of wire

Cross-sectional areas of connection wiring with different rated currents

Rated current (A)	10	16 20	25	32	40 50	63	80	100	125 140	160	180 200 225	250	315 350	400
Rated current (mm <sup>2</sup> )	1.5	2.5	4	6	10	16	25	35	50	70	95	120	185	240

Rated current (A)	Cable		Copper bar	
	Sectional area (mm <sup>2</sup> )	Quantity	Size	Quantity
500	150	2	30×5	2
630	185	2	40×5	2

### Fixed connection

Terminal part

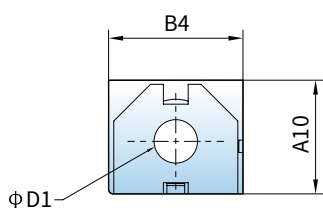

Conductor section

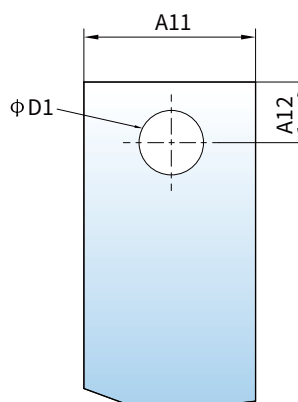

Model	B4	A10	A11	A12	ΦD1
VM5-320	24	20.5	20	9.5	9
VM5-630	32	30	30	15	12.5

# VB2

Miniature Circuit Breaker

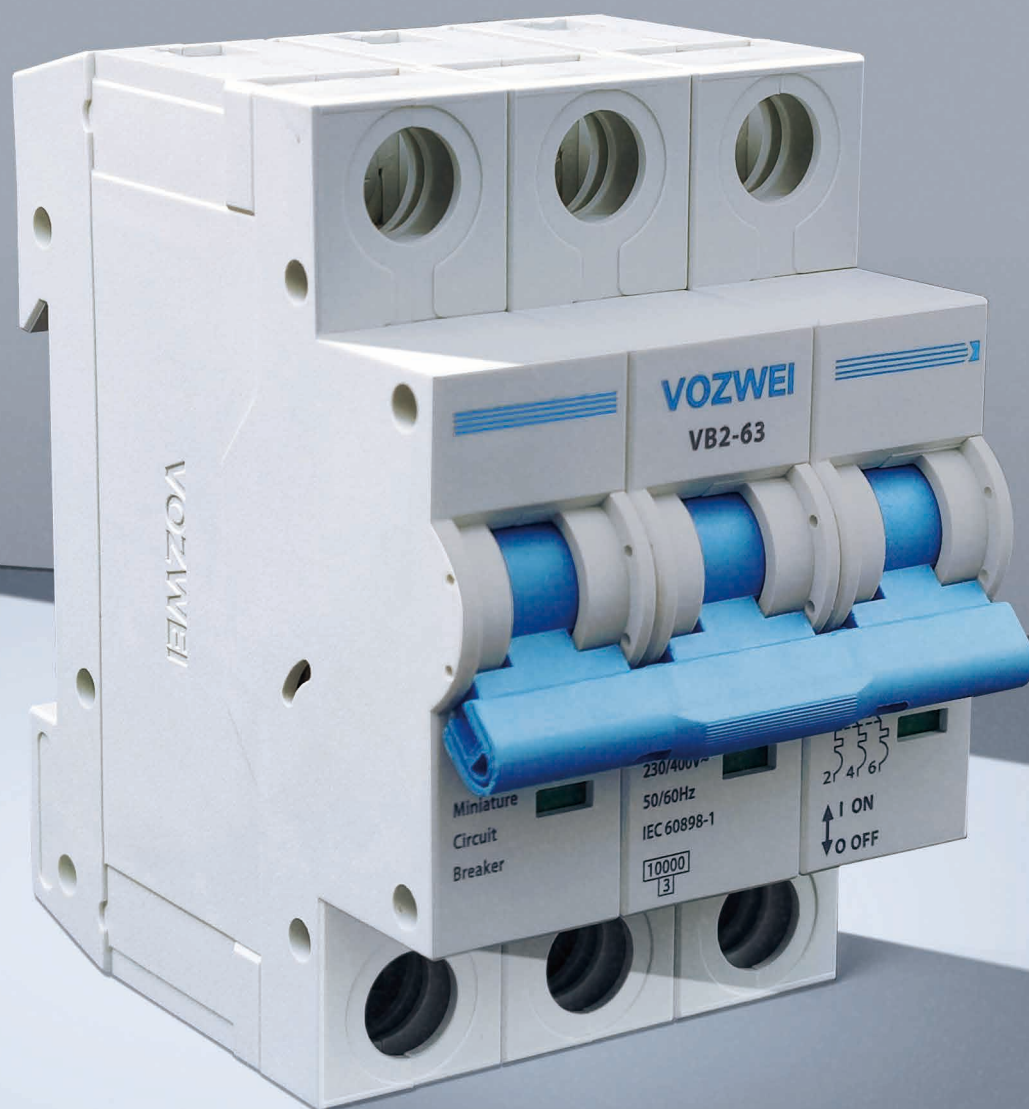



- Quick closing ensures reliable operation and extends the lifetime of circuit breakers
- The temperature-rise of the product itself is lower
- Rated impulse withstand voltage up to 6.0kV
- Tunnel type wiring structure and busbar type wiring structure, reliable and fast wiring
- Modular and modular structure, can be combined arbitrarily

## Ambient conditions

### Operating ambient temperature/storage temperature

- Operating environment temperature:  $-40\text{ }^{\circ}\text{C}\sim+70\text{ }^{\circ}\text{C}$ , with an average value of no more than  $+35\text{ }^{\circ}\text{C}$  within 24 hours
- Storage temperature:  $-40\text{ }^{\circ}\text{C}\sim+80\text{ }^{\circ}\text{C}$

### Altitude conditions

- Altitude of installation site  $\leq 2000\text{m}$  (Over 2000 meters need capacity reduction for using)

### Damp heat resistance

- Category 2 (at a temperature of  $55\text{ }^{\circ}\text{C}$  and a relative humidity of 95%)

### Pollution level

- Level 2

### Protection level

- Product protection level: IP20

### Installation Category

- Class II (load) and Class III (distribution and control)

### Installation method

- Installed on  $\text{TH}35\text{mm} \times 7.5$  (EN50022) Standard Guide

### Installation Direction

- Vertical installation of the product, with an inclination of  $\leq \pm 5^{\circ}$  between the installation surface and the vertical surface
- Horizontal installation

### Environmental requirements

- The product meets RoHS standards

## Technical parameters

Series		VB2-63
		
Rated Operational Voltage ( $U_e$ )	AC 230/400V, DC 48/60V (1P/2P)	
Rated Current	1A, 2A, 3A, 4A, 6A, 8A, 10A, 13A, 16A, 20A, 25A, 32A, 35A, 40A, 50A, 63A	
Tripping Characteristic	B Curve $3I_n \sim 5I_n$ , C Curve $5I_n \sim 10I_n$ , D Curve $10I_n \sim 14I_n$	
Number of Poles	1P, 2P, 3P, 4P	
Rated Insulation Voltage ( $U_i$ )	690 V	
Rated Impulse Withstand Voltage ( $U_{imp}$ )	6.0 kV	
Rated Short-Circuit Capacity ( $I_{cn}$ )	10.0kA (Type B/C, $I_n=1-63A$ ), 6.0kA (Type D, $I_n=1-63A$ )	
Running Short-Circuit Capacity ( $I_{cs}$ )	10.0kA (Type B/C, $I_n=1-40A$ ), 7.5kA (Type B/C, $I_n=50A, 63A$ ), 6.0kA (Type D, $I_n=1-63A$ )	
Rated Frequency	50/60 Hz	
Operating performance	Mechanical Endurance	15000 Cycle
	Electrical Endurance	10000 Cycle
Standard	IEC 60898-1	
Connection	Tunnel type, Bus-bar	
Connecting Capacity	1.0 mm <sup>2</sup> ...25 mm <sup>2</sup>	
Tightening Torque	2.5 N·m	

## VB2-63 Main Characteristics

**VOZWEI**

<b>VB2</b>	–	<b>63</b>	<b>C</b>	<b>63</b>	/	<b>1</b>
1		2	3	4		5

SN	Name	Specification, type code
1	Design code	VB2: Design code
2	Frame rating	63: 63A
3	Tripping characteristic	B: $3I_n \sim 5I_n$ C: $5I_n \sim 10I_n$ D: $10I_n \sim 14I_n$
4	Rated current	1A, 2A, 3A, 4A, 6A, 8A, 10A, 13A, 16A, 20A, 25A, 32A, 35A, 40A, 50A, 63A
5	Number of poles	1P, 2P, 3P, 4P

### Temperature and Breaking Capacity Coefficient

Ambient °C	-40 °C	-30 °C	-20 °C	-10 °C	0 °C	10 °C	20 °C	30 °C	40 °C	50 °C	60 °C	70 °C
Coefficient	133.97%	125.18%	119.90%	116.95%	113.05%	109.52%	105.62%	100%	95.24%	91.33%	88.38%	83.62%

### Breaking Capacity Coefficient and High Altitude Derating Tables

Altitude	Rated current	Rated voltage	Rated frequency voltage tolerance	Breaking Capacity	Breaking Capacity and Electrical life
2 km	$1.00I_n$	$U_e$	1.00	1.00	1.00
3 km	$0.96I_n$	$U_e$	0.92	0.88	0.88
4 km	$0.92I_n$	$U_e$	0.83	0.82	0.82
5 km	$0.87I_n$	$U_e$	0.77	0.70	0.70

# VB2-63 Characteristic Curve

VOZWEI

## B curve

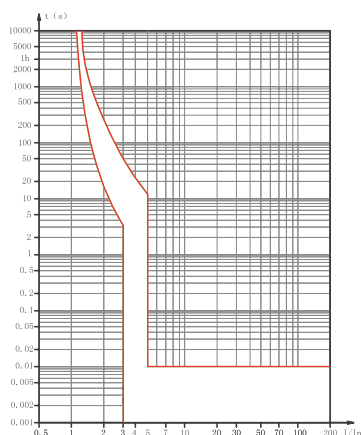

Protection against loads with small short circuit currents (e.g., non-inductive or micro-inductive circuits)

**Trip characteristics:**

The instantaneous trip range is  $3I_n \sim 5I_n$

**Base temperature:**

+30°C

## C curve

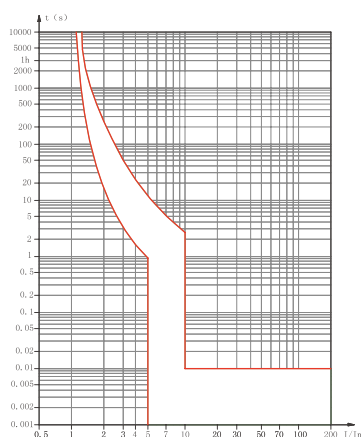

Protection of conventional loads and distribution circuits

**Trip characteristics:**

The instantaneous trip range is  $5I_n \sim 10I_n$

**Base temperature:**

+30°C

## D curve

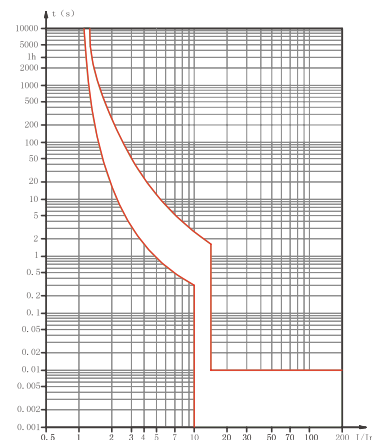

Protection of impulse loads with large starting current (e.g., motors, transformers, etc.)

**Trip characteristics:**

The instantaneous trip range is  $10I_n \sim 14I_n$

**Base temperature:**

+30°C

## Overall and Mounting Dimensioned

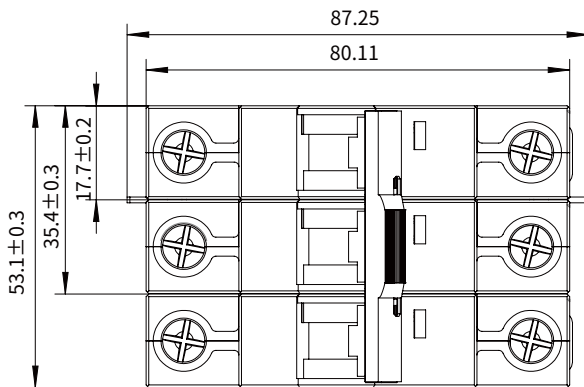
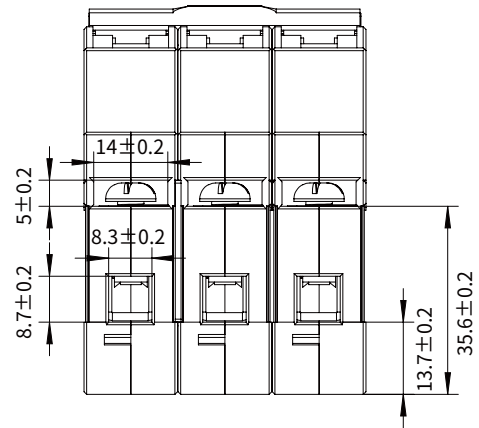
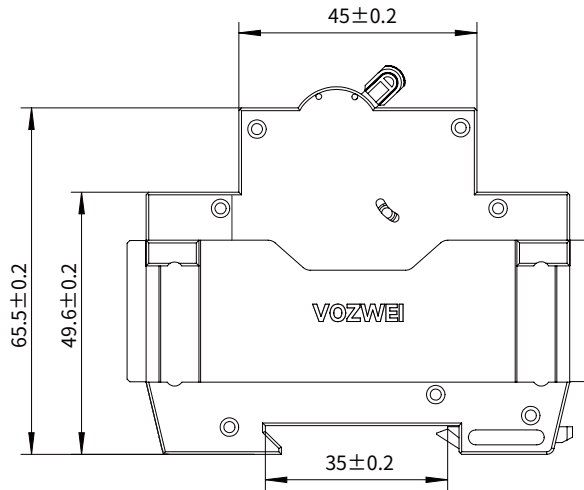

## Wiring Diagram

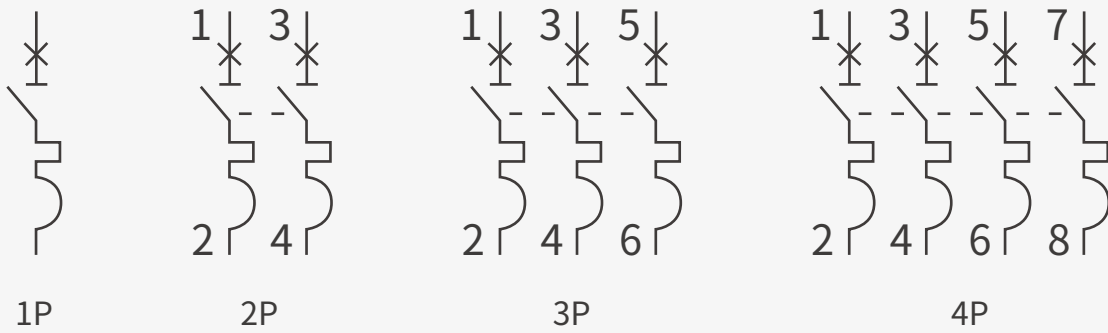

## Technical parameters

Series		VB2T-63
		
Rated Operational Voltage ( $U_e$ )	AC 230/400V (1P), AC 400/415V (2P, 3P, 4P), DC 60/80V (1P), DC 80/125V (2P)	
Rated Current	1A, 2A, 3A, 4A, 6A, 8A, 10A, 13A, 16A, 20A, 25A, 32A, 35A, 40A, 50A, 63A	
Tripping Characteristic	B Curve $4I_n \pm 20\%$ , C Curve $8I_n \pm 20\%$ , D Curve $12I_n \pm 20\%$ , K Curve $10I_n \pm 20\%$ , Z Curve $2.5I_n \pm 20\%$	
Number of Poles	1P, 2P, 3P, 4P	
Rated Insulation Voltage ( $U_i$ )	690 V	
Rated Impulse Withstand Voltage ( $U_{imp}$ )	6.0 kV	
Rated Short-Circuit Capacity ( $I_{cu}$ )	10.0kA	
Running Short-Circuit Capacity ( $I_{cs}$ )	10.0kA	
Rated Frequency	50/60 Hz	
Operating performance	Mechanical Endurance	15000 Cycle
	Electrical Endurance	10000 Cycle
Standard	IEC 60947-2	
Connection	Tunnel type, Bus-bar	
Connecting Capacity	1.0 mm <sup>2</sup> ...25 mm <sup>2</sup>	
Tightening Torque	2.5 N·m	

# VB2T-63 Main Characteristics

**VOZWEI**

<b>VB2T</b>	–	<b>63</b>		<b>C</b>		<b>63</b>	/	<b>1</b>
1		2		3		4		5

SN	Name	Specification, type code
1	Design code	VB2T: Design code
2	Frame rating	63: 63A
3	Tripping characteristic	B, C, D, K, Z
4	Rated current	1A, 2A, 3A, 4A, 6A, 8A, 10A, 13A, 16A, 20A, 25A, 32A, 35A, 40A, 50A, 63A
5	Number of poles	1P, 2P, 3P, 4P

## Temperature and Breaking Capacity Coefficient

Ambient °C	-40 °C	-30 °C	-20 °C	-10 °C	0 °C	10 °C	20 °C	30 °C	40 °C	50 °C	60 °C	70 °C
Coefficient	133.97%	125.18%	119.90%	116.95%	113.05%	109.52%	105.62%	100%	95.24%	91.33%	88.38%	83.62%

## Breaking Capacity Coefficient and High Altitude Derating Tables

Altitude	Rated current	Rated voltage	Rated frequency voltage tolerance	Breaking Capacity	Breaking Capacity and Electrical life
2 km	1.00I <sub>n</sub>	U <sub>e</sub>	1.00	1.00	1.00
3 km	0.96I <sub>n</sub>	U <sub>e</sub>	0.92	0.88	0.88
4 km	0.92I <sub>n</sub>	U <sub>e</sub>	0.83	0.82	0.82
5 km	0.87I <sub>n</sub>	U <sub>e</sub>	0.77	0.70	0.70

# VB2T-63 Characteristics Curve

VOZWEI

## B curve

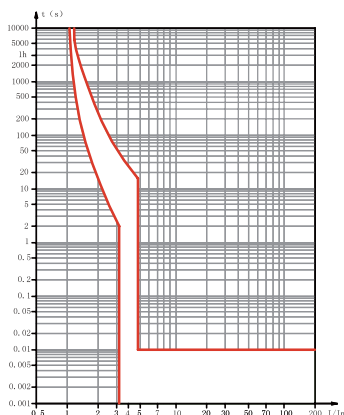

Protection against loads with small short circuit currents (e.g., non-inductive or micro-inductive circuits)

**Trip characteristics:**

The instantaneous trip range is  $4I_n \pm 20\%$

**Base temperature:**

+30°C

## C curve

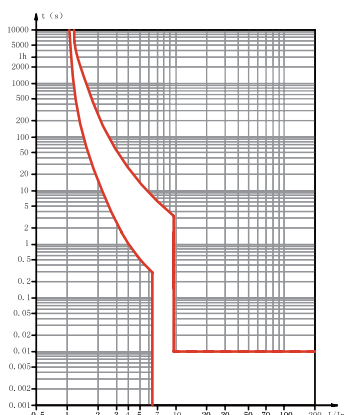

Protection of conventional loads and distribution circuits

**Trip characteristics:**

The instantaneous trip range is  $8I_n \pm 20\%$

**Base temperature:**

+30°C

## D curve

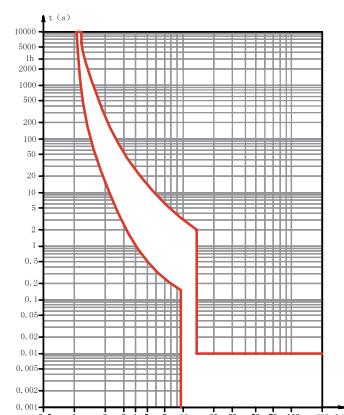

Protection of impulse loads with large starting current (e.g., motors, transformers, etc.)

**Trip characteristics:**

The instantaneous trip range is  $12I_n \pm 20\%$

**Base temperature:**

+30°C

## K curve

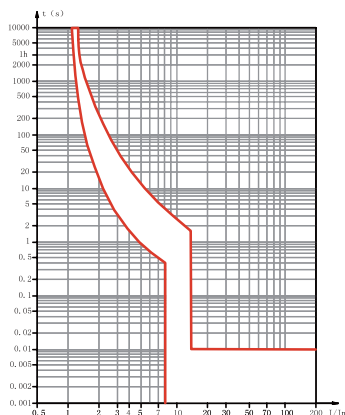

Protection of impulse loads with large starting current

**Trip characteristics:**

The instantaneous trip range is  $10I_n \pm 20\%$

**Base temperature:**

+30°C

## Z curve

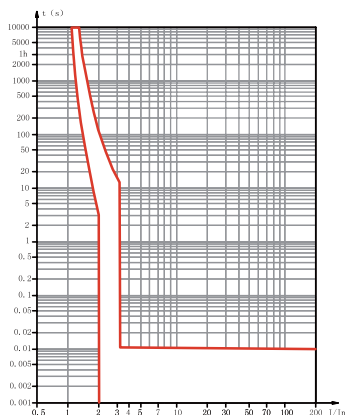

Protecting loads or distribution circuits that require more sensitive action

**Trip characteristics:**

The instantaneous trip range is  $2.5I_n \pm 20\%$

**Base temperature:**

+30°C

## Overall and Mounting Dimensioned

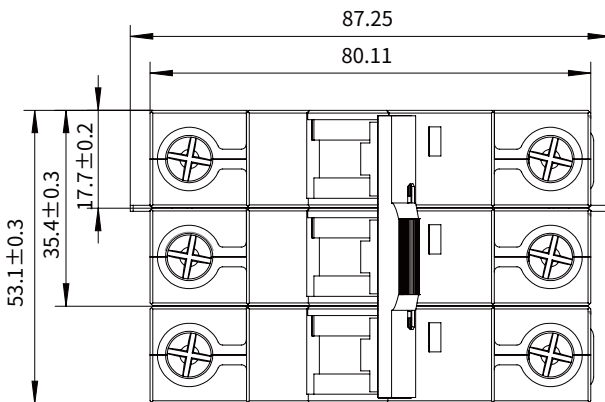
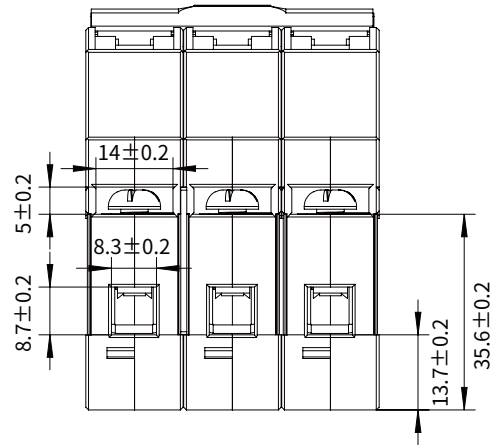
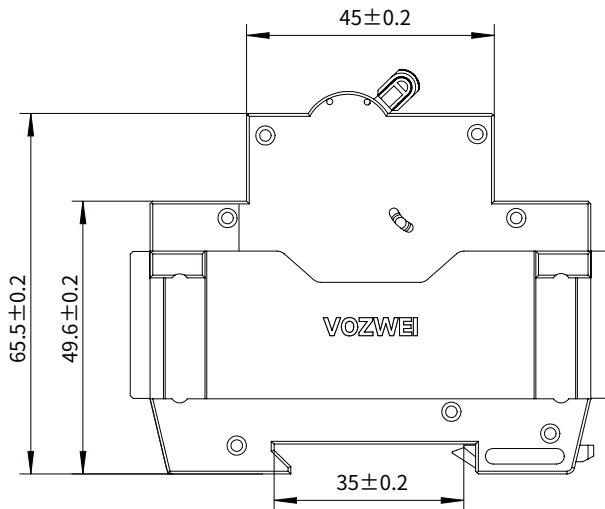

## Wiring Diagram

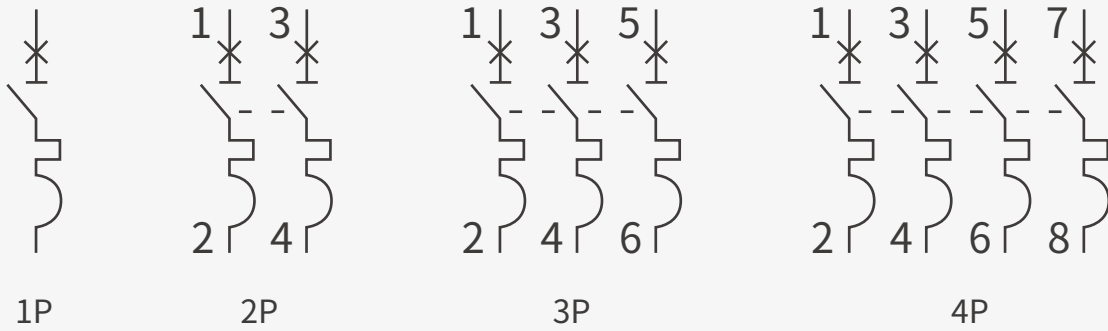

## Technical parameters

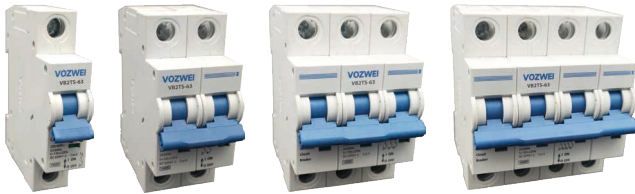
Series	VB2TS-63 (Magnetic protection only)	
		
Rated Operational Voltage ( $U_e$ )	AC 230/400V (1P), AC 400/415V (2P, 3P, 4P), DC 60/80V (1P), DC 80/125V (2P)	
Rated Current	1A, 2A, 3A, 4A, 6A, 8A, 10A, 13A, 16A, 20A, 25A, 32A, 35A, 40A, 50A, 63A	
Tripping Characteristic	B Curve $4I_n \pm 20\%$ , C Curve $8I_n \pm 20\%$ , D Curve $12I_n \pm 20\%$	
Number of Poles	1P, 2P, 3P, 4P	
Rated Insulation Voltage ( $U_i$ )	690 V	
Rated Impulse Withstand Voltage ( $U_{imp}$ )	6.0 kV	
Rated Short-Circuit Capacity ( $I_{cu}$ )	10.0kA	
Running Short-Circuit Capacity ( $I_{cs}$ )	10.0kA	
Rated Frequency	50/60 Hz	
Operating performance	Mechanical Endurance	15000 Cycle
	Electrical Endurance	10000 Cycle
Standard	IEC 60947-2	
Connection	Tunnel type, Bus-bar	
Connecting Capacity	1.0 mm <sup>2</sup> ...25 mm <sup>2</sup>	
Tightening Torque	2.5 N·m	

<b>VB2T</b>	<b>S</b>	-	<b>63</b>	<b>C</b>	<b>63</b>	/	<b>1</b>
1	2		3	4	5		6

SN	Name	Specification, type code
1	Design code	VB2T: Design code
2	Function code	S: Magnetic protection only
3	Frame rating	63: 63A
4	Tripping characteristic	B, C, D
5	Rated current	1A, 2A, 3A, 4A, 6A, 8A, 10A, 13A, 16A, 20A, 25A, 32A, 35A, 40A, 50A, 63A
6	Number of poles	1P, 2P, 3P, 4P

# VB2TS-63 Characteristics Curve

VOZWEI

## B curve

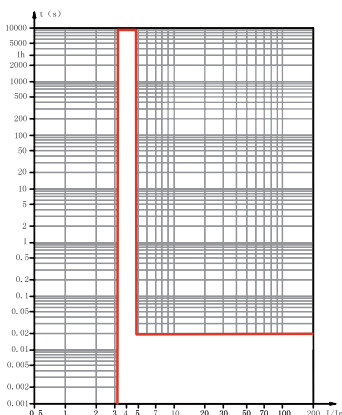

Protection against loads with small short circuit currents (e.g., non-inductive or micro-inductive circuits)

**Trip characteristics:**

The instantaneous trip range is  $4I_n \pm 20\%$

**Base temperature:**

+30°C

## C curve

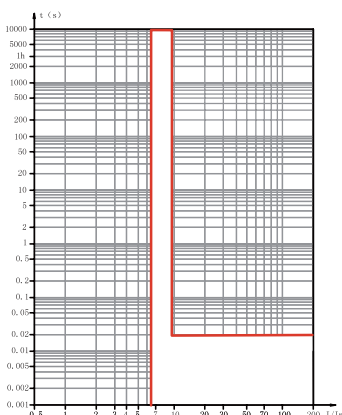

Protection of conventional loads and distribution circuits

**Trip characteristics:**

The instantaneous trip range is  $8I_n \pm 20\%$

**Base temperature:**

+30°C

## D curve

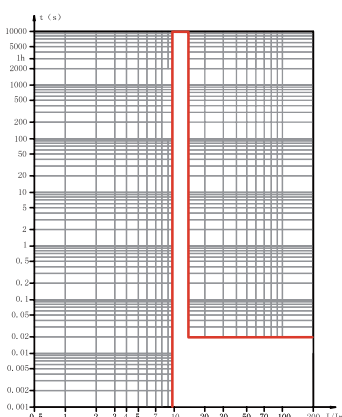

Protection of impulse loads with large starting current (e.g., motors, transformers, etc.)

**Trip characteristics:**

The instantaneous trip range is  $12I_n \pm 20\%$

**Base temperature:**

+30°C

## Overall and Mounting Dimensioned

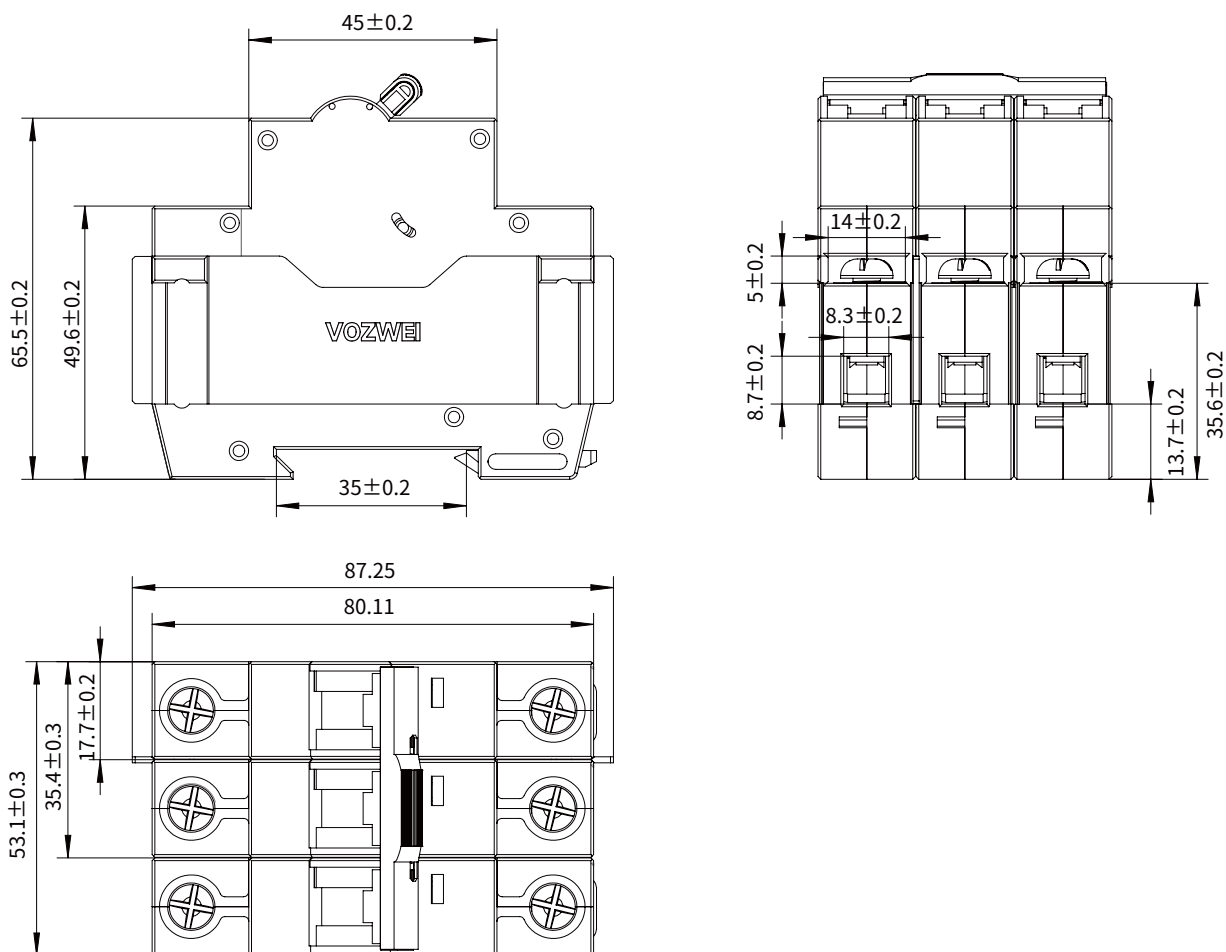

## Wiring Diagram

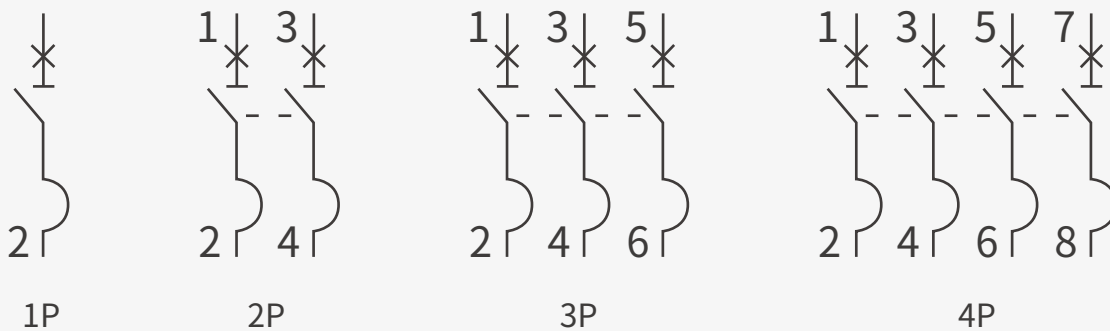

## Technical parameters

Series		VB2Z-63
		
Rated Operational Voltage ( $U_e$ )	DC 125/220/250V (1P), DC 250/440/500/690/800V (2P), DC 750/800V (3P), DC 800/1000V (4P)	
Rated Current	1A, 2A, 3A, 4A, 6A, 8A, 10A, 13A, 16A, 20A, 25A, 32A, 35A, 40A, 50A, 63A	
Tripping Characteristic	B Curve $6I_n \pm 20\%$ , C Curve $12I_n \pm 20\%$	
Number of Poles	1P, 2P, 3P, 4P	
Rated Insulation Voltage ( $U_i$ )	1000 V	
Rated Impulse Withstand Voltage ( $U_{imp}$ )	6.0 kV	
Rated Short-Circuit Capacity ( $I_{cu}$ )	DC 125/220/250V (1P), DC 250/440/500V (2P):10kA DC 690/800V (2P):6kA DC 750/800V (3P), DC 800/1000V (4P):5kA	
Running Short-Circuit Capacity ( $I_{cs}$ )	DC 125/220/250V (1P):7.5kA DC 250/440/500V (2P):6kA DC 690V (2P):4.5kA DC 800V (2P):3kA DC 750/800V (3P):5kA DC 800/1000V (4P):5kA	
Operating performance	Mechanical Endurance	15000 Cycle
	Electrical Endurance	10000 Cycle
Standard	IEC 60947-2	
Connection	Tunnel type, Bus-bar	
Connecting Capacity	1.0 mm <sup>2</sup> ...25 mm <sup>2</sup>	
Tightening Torque	2.5 N·m	

## VB2Z-63 Main Characteristics

**VOZWEI**

<b>VB2</b>	<b>Z</b>	–	<b>63</b>	<b>C</b>	<b>63</b>	/	<b>1</b>
1	2		3	4	5		6

SN	Name	Specification, type code
1	Design code	VB2: Design code
2	Function code	Z: DC type
3	Frame rating	63: 63A
4	Tripping characteristic	B, C
5	Rated current	1A, 2A, 3A, 4A, 6A, 8A, 10A, 13A, 16A, 20A, 25A, 32A, 35A, 40A, 50A, 63A
6	Number of poles	1P, 2P, 3P, 4P

### Temperature and Breaking Capacity Coefficient

Ambient °C	-40 °C	-30 °C	-20 °C	-10 °C	0 °C	10 °C	20 °C	30 °C	40 °C	50 °C	60 °C	70 °C
Coefficient	131.59%	127.14%	123.10%	118.81%	114.40%	109.76%	105.07%	100%	94.44%	88.77%	82.63%	76.20%

# VB2Z-63 Characteristics Curve

VOZWEI

## B curve

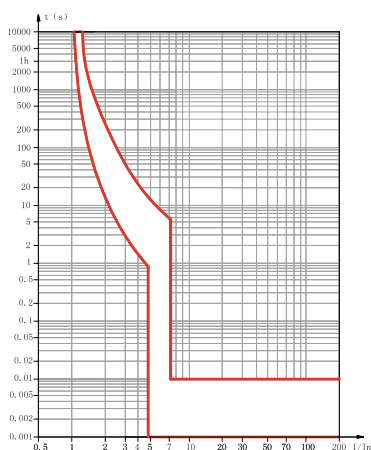

Protection against loads with small short circuit currents (e.g., non-inductive or micro-inductive circuits)

**Trip characteristics:**

The instantaneous trip range is  $6(1 \pm 20\%) I_n$

**Base temperature:**

+30°C

## C curve

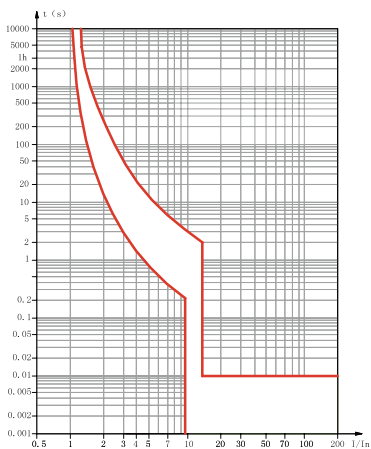

Protection of conventional loads and distribution circuits

**Trip characteristics:**

The instantaneous trip range is  $12(1 \pm 20\%) I_n$

**Base temperature:**

+30°C

## Overall and Mounting Dimensioned

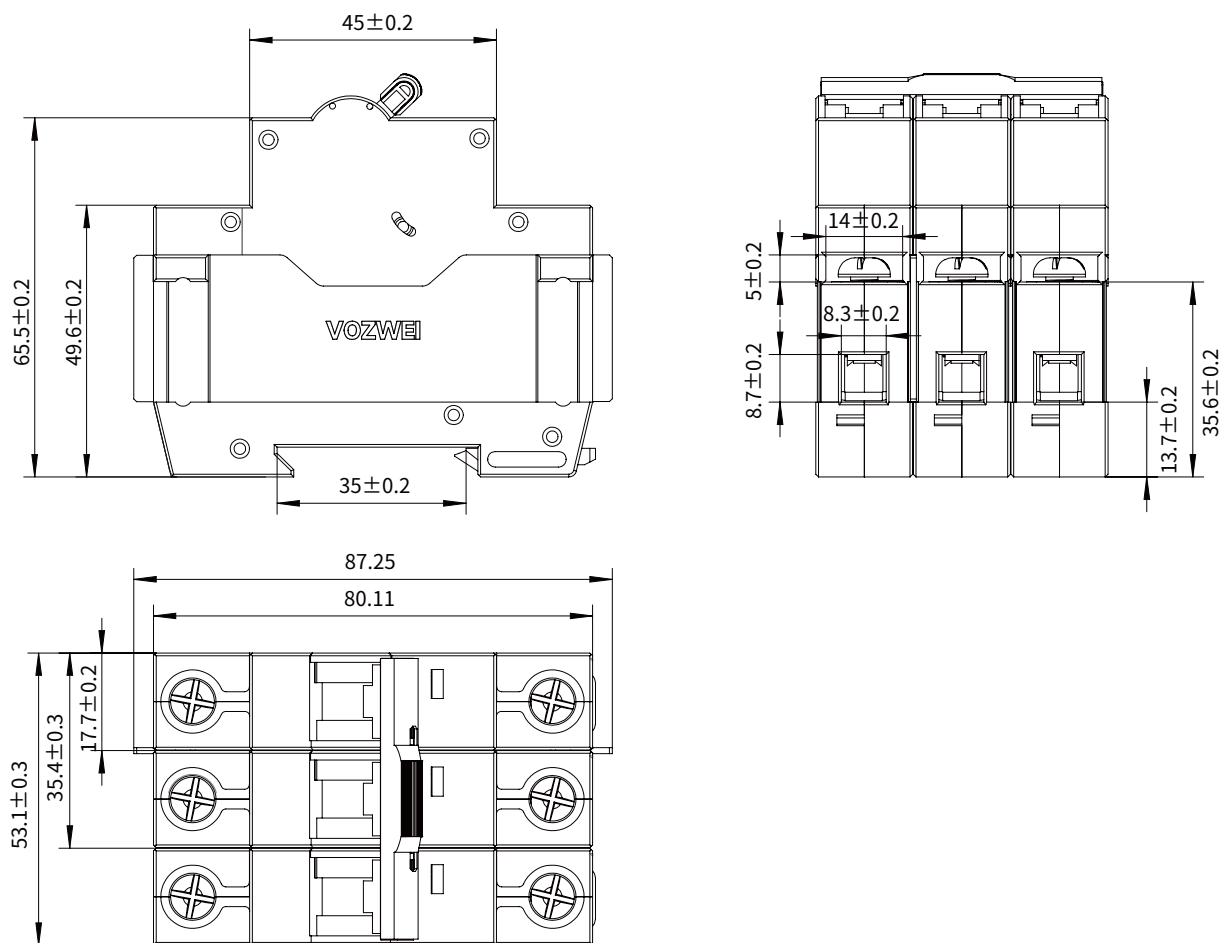

## Wiring Diagram

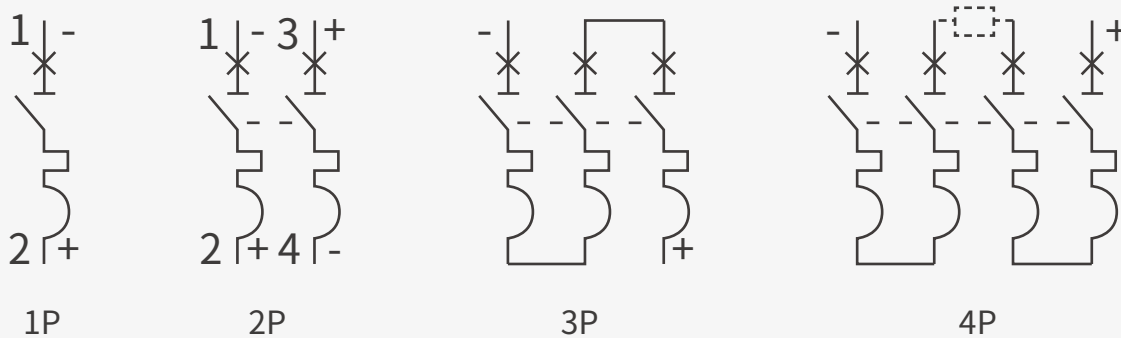

## Shanghai Vozwei Electric Technology Co., Ltd.

**Address:** Sales and Marketing: No. 166, Miyi Road,  
Sijing Town, Songjiang District, Shanghai China.

**Postcode:** 201601

**Telephone:** +86-21-33555507

**Url:** [www.vozwei.com](http://www.vozwei.com)

**Email:**

[rfq@vozwei.com](mailto:rfq@vozwei.com) (Inquiry for price)

[dis@vozwei.com](mailto:dis@vozwei.com) (Want to be a distributor)

[support@vozwei.com](mailto:support@vozwei.com) (Get technical support)

[info@vozwei.com](mailto:info@vozwei.com) (Others information)